



INSTALLATION AND OPERATION MANUAL

Versione software: 2.1x

code 80962E - 07-2015 - ENG



INDEX

1	Preliminary instructions	2	3.4	Connector J1 outputs 5...10	
1.1	Profile		3.5	Connector J2 power supply	
1.2	General description		3.6	Connector J3 digital input	
1.3	Preliminary instructions		3.7	Connector J4 auxiliary inputs 2...5	
2	Installation and Connection	4	3.8	Connector J5 analogic inputs	
2.1	Electrical power supply		3.9	Connector J6: inputs PID	
2.2	Notes on electrical safety and electromagnetic compatibility		3.10	Description of dip-switches	
2.3	Recommendations for correct installation for purposes of EMC		3.11	Serial communication ports	
2.4	Dimensions		3.12	Connection example: Power section	
2.5	Template dimensions		3.13	Note use with inductive loads and transformers	
2.6	Installation		3.14	Trigger modes	
2.7	General description GFW		3.15	Digital input (PWM)	
2.8	Cleaning/checking or replacing the fan		4	Installation of serial network	43
2.9	Replacing internal fuse (Optional)		4.1	"AUTOBAUD SERIAL 1" sequence	
2.10	Card insertion for fieldbus interface		4.2	"AUTONODE PORT 1" sequence	
2.11	Connection of expansion modules		5	Technical Characteristics	45
3	Electrical connections	14	5.1	Derating Curves Gfw	
3.1	Power connections		6	Technical-Commercial information	50
3.2	Functions of LED indicators		6.1	Order code	
3.3	Description Input/Output		6.2	Accessories	
			6.3	Fuses	

GRAPHIC SYMBOLS

To differentiate the type and importance of the information in this User Manual, graphic reference symbols are used to make such information easier to interpret.



Indicates contents of sections, general instructions, notes, and other points to which the reader's attention needs to be called.



Indicates a suggestion based on the experience of GEFRAN's Technical Personnel that could be especially useful under certain circumstances.



Indicates a particularly delicate situation that could affect the safety or correct operation of the controller, or an instruction that **MUST** be followed to prevent hazards.



Indicates a reference to Detailed Technical Documents available on the GEFRAN website www.gefran.com.



Indicates a risk to the user's safety due to high voltage at the points indicated.

1.1 PROFILE

The “GFW” **series of** microprocessor advanced solid state power units controls high electric powers with different types of heating elements, single-phase, biphas or triphase.

Current levels range from 40A to 250A, nominal voltage from 480Vac ,600Vac, 690Vac.

The command input is configurable and accepts 0-10V, 0/4-20mA signals, potentiometer, logic signals, including with PWM modes for cost effective solutions.

The device can also be operated via Modbus RTU serial communication, with IN/OUT chain connections facilitated by plug-in RJ10 (telephone) connectors.

The several trigger modes are software configurable and provide:

- **ZC**: Zero Crossing constant cycle time (settable in range 1-200sec), for conventional loads

- **BF**: Burst-Firing, Zero crossing with optimized minimum cycle time, for systems with low thermal inertia, medium-wave IR lamps

- **HSC**: Half Single Cycle Zero Crossing corresponds to Burst Firing that manages single semi-cycles of conduction or stop cycles, useful for short-wave IR lamps, reduces flickering and limits generation of EMC noise on the power line (applied only to single-phase load or open delta).

- **PA**: Phase angle control, useful for short-wave IR lamps, transformer primaries. Completely eliminates flickering of load filaments, but generates EMC noise on power line (harmonics).

Soft Start ramp functions can be assigned to these controls, with options such as “current limit” that keeps current peaks at power-on and RMS current level at full power under control.

Thanks to sophisticated Hardware and Software solutions, you can precisely control different types of loads.

Phase angle control (the only control method that completely eliminates IR lamp flickering), matched with **current, voltage, or load power feedback** functions, let you confidently use “critical” applications such as (for example), special resistors such as special Super Khantal™ heating elements, Silicon Carbide resistors, or transformer primaries either single-phase or triphase.

GFW runs complete diagnostics of current, voltage, power, and temperature levels:

Current Diagnostics:

- Total and partial load interrupt alarm
- Self-learn function of alarm limit for interrupted load
- Alarm for SCR in short circuit
- Alarm for load in short circuit or overcurrent
- Alarm for interrupted internal fuse

Voltage Diagnostics:

- Alarm for absence of phase
- Signal for incorrect rotation of 3 phases (for triphase applications)
- Alarm for triphase line unbalance

Temperature Diagnostics:

- Measurement of power module temperature
- Alarm for over temperature of power module
- Measurement of power terminals temperature
- Alarm for over temperature of power terminals
- Alarm for absence of 24V supply to cooling fan

Power control with Soft start ramp limits load, optimizes the consumptions and increases the load operating duration.

Parameters can be configured from an optional keypad with LCD screen that attaches magnetically to the front panel and from PC with the GF_eXpress configuration kit, which lets you save all parameters in a configuration file that is easy to manage and to copy to other devices..

GFW always provides an RS485 serial connection (PORT1) with Modbus RTU protocol to control currents, voltages, powers, load status, and device status from the supervisor terminal (HMI) or PLC.

A second (optional) communication port is offered that lets you choose from among the following Fieldbuses: Modbus RTU, Profibus DP, CanOpen, Devicenet, Modbus-TCP, Ethernet IP, EtherCAT .



The section contains general information and warnings to be read before installing, configuring and using the controller.

1.2 GENERAL DESCRIPTION

GFW is single-zone advanced solid state power unit, extremely compact, equipped with different optional functions; it offers an exclusive combination of performance, reliability, and flexibility.

In particular, this new line of Gefran solid state relays is the ideal solution for sectors demanding high performance and continuity of service, such as:

- *Thermoforming*
- *Blowing*
- *Hot runners for injection presses*
- *Texturizing of fibers*
- *Heat treatment furnaces*
- *Woodworking machines*
- *Glass tempering furnaces*

The modules Series GFW are based on an extremely versatile hardware and software platform, with options to select the best I/O configuration for your system.

GFW is used for the power control of single-phase, Dual-Phase and 3-phase loads, including resistive loads with high and low temperature coefficient, short wave IR lamps, or transformer primaries.



Attention: the description of programming and configuration parameters are contained in the “Programming and configuration” manual, downloadable from the website www.gefran.com

1.2 PRELIMINARY INSTRUCTION

Read the following preliminary instructions before installing and using the GFX4-IR modular power controller.



This will make start-up faster and avoid some problems that could be mistakenly interpreted as malfunctions or limitations of the controller.

Immediately after unpacking the unit, check the order code and the other data on the label attached to the outside of the container.

Write them on the following table.

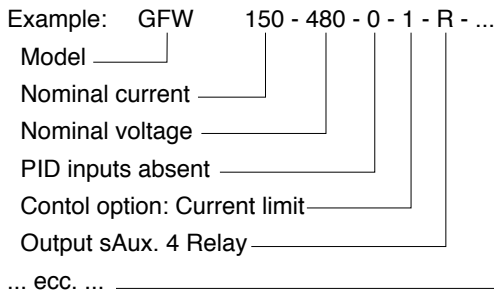
This data must always be available and given to Gefran Customer Care representatives if technical service is needed.

SN.....	(Serial Number)
CODE	(Product code)
TYPE.....	(Order code)
SUPPLY.....	(Type of electrical power supply)
VERS.	(Firmware Version)

Check that the controller is in perfect condition, was not damaged during shipment, and that the package also contains the CD that contains other useful information such as the “Configuration and Programming” manual, memory map etc...

Immediately report any errors, shortages, or signs of damage to your Gefran dealer.

Check that the order code matches the configuration requested for the intended application by consulting the section: “Technical-Commercial Information.”



See paragraph “Dimensions and mounting” before installing the GFW on the machine/host system control panel.

To configure the PC use the SW Gefran GF-Express kit and the relative connection cable.

For the order code, see Section “Technical-Commercial Information”.



Users and/or system integrators who want detailed information on serial communication between Gefran standard and/or industrial PCs and Gefran Programmable Instruments can access Technical Reference Documents on serial communication and MODBUS protocol, etc., in Adobe Acrobat format on the Gefran website **www.gefran.com**:

- Serial Communication
- MODBUS Protocol
- FIELDBUS protocols (Various)

Before calling Gefran Customer Care in case of assumed malfunctions, please see the Troubleshooting Guide in the “Maintenance” section and, if necessary, the F.A.Q. (Frequently Asked Questions) section on the Gefran website

www.gefran.com

2 · INSTALLATION AND CONNECTION



This section contains the instructions needed for correct installation of GFW modular power controller on the machine/host system control panel and for correct connection of the power supply, inputs, outputs and interfaces.



CAREFULLY READ THE FOLLOWING WARNINGS BEFORE INSTALLING THE INSTRUMENT!

Disregard of such warnings could create electrical safety and electromagnetic compatibility problems, as well as void the warranty.

2.1 ELECTRICAL POWER SUPPLY

- the controller DOES NOT have an On/Off switch: the user must install switch/isolator conforming to safety requisites (CE mark) to cut off the power supply up-line of the controller.

The switch must be installed in the immediate vicinity of the controller in easy reach of the operator.

A single switch can be used for multiple devices.

* the earth connection must be made with a specific lead

- if the product is used in applications with risk of harm to persons or damage to machines or materials, it MUST be equipped with auxiliary alarm devices.
It is advisable to provide the ability to check for tripped alarms during regular operation.
DO NOT install the product in rooms with hazardous (inflammable or explosive) atmosphere; it may be connected to elements that operated in such atmosphere only by means of appropriate interfaces that conform to current safety standards.

2.2 NOTES ON ELECTRICAL SAFETY AND ELECTROMAGNETIC COMPATIBILITY:

2.2.1 MARCATURA CE: EMC

(electromagnetic compatibility) conformity

in compliance with Directive 89/336/CEE and following modifications.

Series GFW are mainly intended for industrial use, installed on panels or control panels of production process machines or systems.

For purposes of electromagnetic compatibility, the most restrictive generic standards have been adopted, as shown on the table.

2.2.2 LV (low voltage) conformity

in compliance with Directive 2006/95/CE.



EMC compliance has been verified with respect to the information in Tables 1 and 2.

2.3 RECOMMENDATIONS FOR CORRECT INSTALLATION FOR PURPOSES OF EMC

2.3.1 Instrument power supply

- The power supply for the electronic instrumentation on the panels must always come directly from a cut-off device with fuse for the instrument part.
- Electronic instrumentation and electromechanical power devices such as relays, contactors, solenoids, etc., MUST ALWAYS be powered by separate lines.
- When the power supply line of electronic instruments is heavily disturbed by switching of thyristor power groups or by motors, you should use an isolation transformer only for the controllers, grounding its sheathing.
- It is important for the system to be well-grounded:
 - voltage between neutral and ground must not be $> 1V$
 - Ohmic resistance must be $< 6\Omega$;
- If the grid voltage is highly unstable, use a voltage stabilizer.
- In proximity of high-frequency generators or arc welders, use adequate grid filters.
- The power supply lines must be separate from instrument input and output lines.



- Supply from Class II or from limited energy source

2.3.2 Input and output connections

Before connecting or disconnecting any connection, always check that the power and control cables are isolated from voltage

Appropriate devices must be provided: fuses or automatic switches to protect power lines.

The fuses present in the module function solely as a protection for the GFW semiconductors.

- Connected outside circuits must be doubly isolated.
- To connect analog inputs, strain gauges, linears, (TC, RTD), you have to:
 - physically separate the input cables from those of the power supply, outputs, and power connections.
 - use braided and shielded cables, with sheathing grounded at a single point.

2.3.3 Installation notes

Use the extra-rapid fuse indicated in the catalogue according to the connection example equipped.

- Moreover, the applications with solid-state units require a safety automatic switch to section the load power line.
To ensure the high reliability of the device, it is necessary to install it properly inside the panel so to obtain an adequate thermal exchange. Fit the device vertically (maximum angle 10° to the vertical axis) see figure 3
- Vertical distance between a device and the panel wall $>100\text{mm}$
- Horizontal distance between a device and the panel wall at last 10mm
- Vertical distance between a device and the next one at last 300mm.
- Horizontal distance between a device and the next one at last 10mm.

Check that the cable holder runners do not reduce these distances, in this case fit the cantilever units opposite the panel so that the air can flow vertically without any obstacles.

- dissipation of device thermal power with effects on installation room temperature.
- thermal power dissipation with limits on installation room temperature.
- requires exchange with external air or an air conditioner to transfer dissipated power outside the panel.
- maximum limits of voltage and derived power of transients on the line, for which the solid state power unit contains protective devices (based on the model).
- presence of dispersion current in GFW in non-conducting state (current of a few mA due to RC Snubber circuit to protect the thyristor).



GEFRAN S.p.A. assumes no liability for any damage to persons or property deriving from tampering, from incorrect or improper use, or from any use not conforming to the characteristics of the controller and to the instructions in this User Manual.

Table 1 EMC Emission

AC semiconductor motor controllers and conductors for non-motor loads	EN 60947-4-3	
Emission enclosure compliant in firing mode single cycle and phase angle if external filter fitted	EN 60947-4-3 CISPR-11 EN 55011	Class A Group 2

Table 2 EMC Immunity

Generic standards, immunity standard for industrial environments	EN 60947-4-3	
ESD immunity	EN 61000-4-2	4 kV contact discharge 8 kV air discharge
RF interference immunity	EN 61000-4-3 /A1	10 V/m amplitude modulated 80 MHz-1 GHz 10 V/m amplitude modulated 1.4 GHz-2 GHz
Conducted disturbance immunity	EN 61000-4-6	10 V/m amplitude modulated 0.15 MHz-80 MHz
Burst immunity	EN 61000-4-4	2 kV power line 2 kV I/O signal line
Surge immunity	EN 61000-4-4/5	Power line-line 1 kV Power line-earth 2 kV Signal line-earth 2 kV Signal line-line 1 kV
Magnetic fields immunity	Test are not required. Immunity is demonstrated by the successful completion of the operating capability test	
Voltage dips, short interruptions and voltage immunity tests	EN 61000-4-11	100%U, 70%U, 40%U,

Table 3 LVD safety

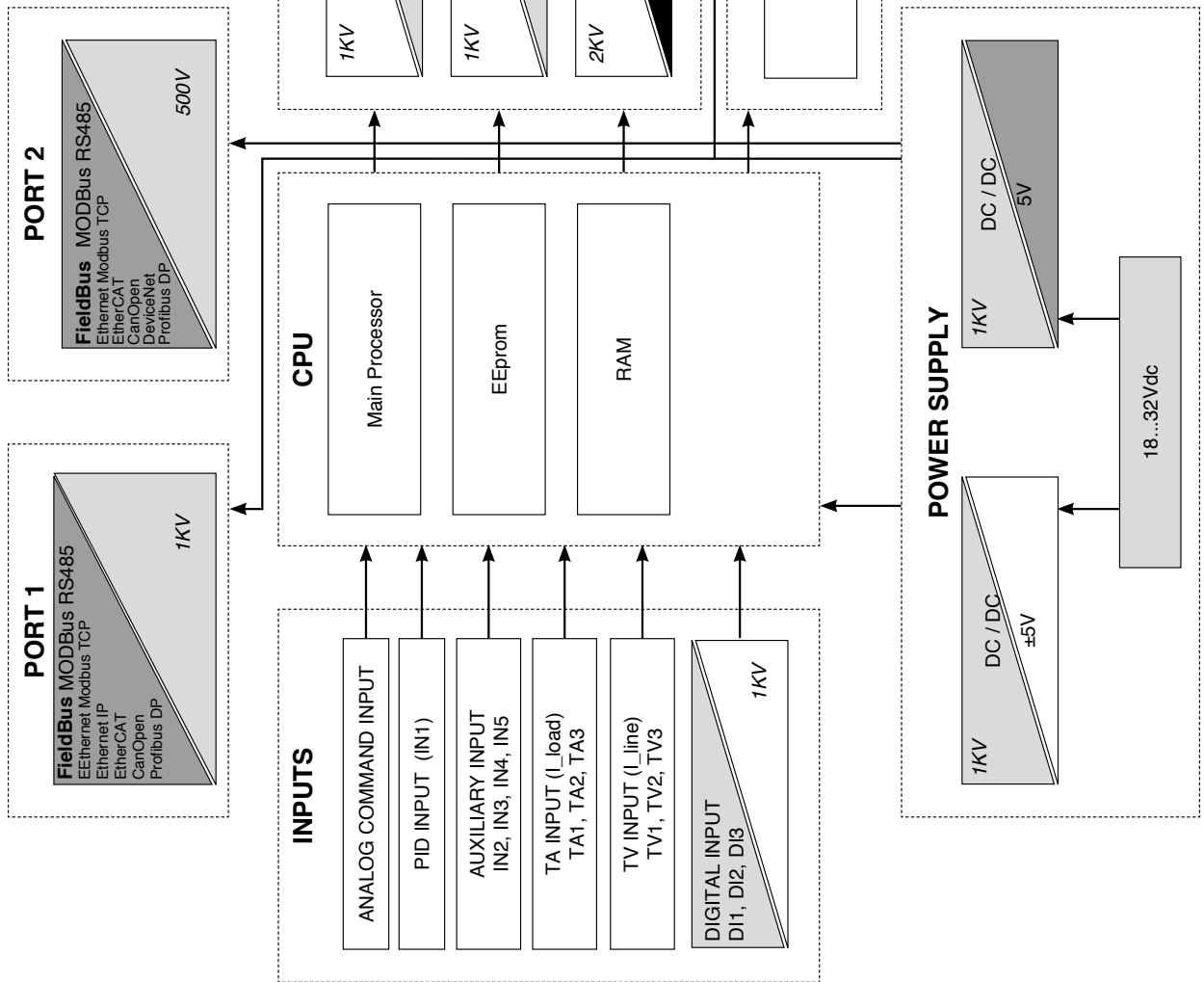
Safety requirements for electrical equipment for measurement, control and laboratory use	EN 61010-1	
--	------------	--

ATTENTION

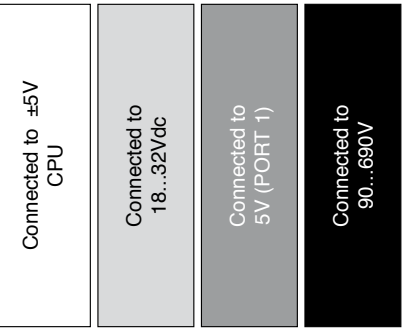
This product has been designed for class A equipment. Use of the product in domestic environments may cause radio interference, in which case the user may be required to employ additional mitigation methods.

EMC filters are required in PA mode (Phase Angle, i.e., SCR trigger with phase angle modulation).
The filter model and current level depend on the configuration and load used.
The power filter **MUST** be connected as close as possible to the GFW.
You can use a filter connected between the power line and GFW or an LC group connected between the GFW output and the load

INSULATION DIAGRAM



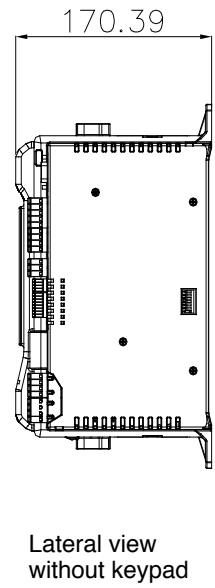
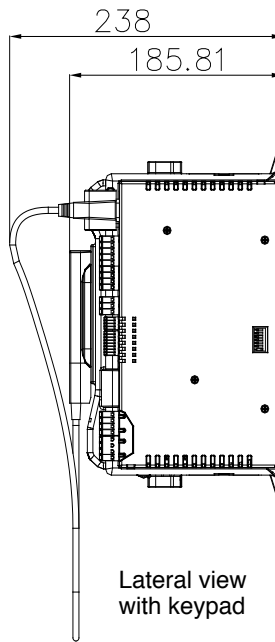
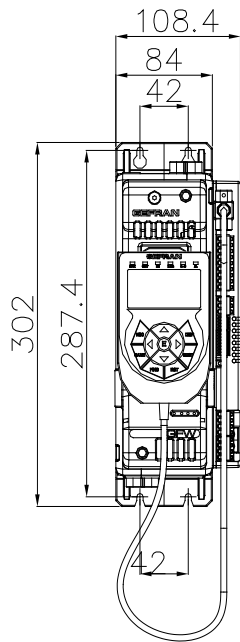
Legend



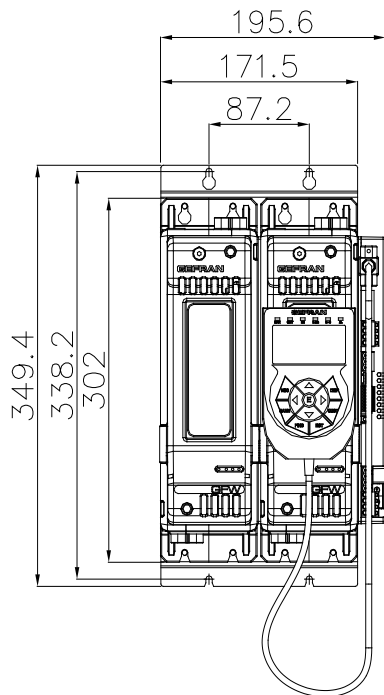
2.4 DIMENSIONS

Figure 1

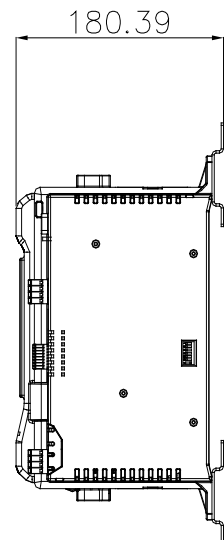
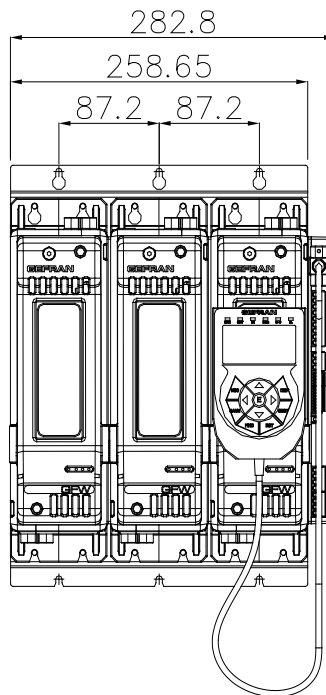
GFW MASTER



GFW DUAL-PHASE (Master + 1 Expansion)



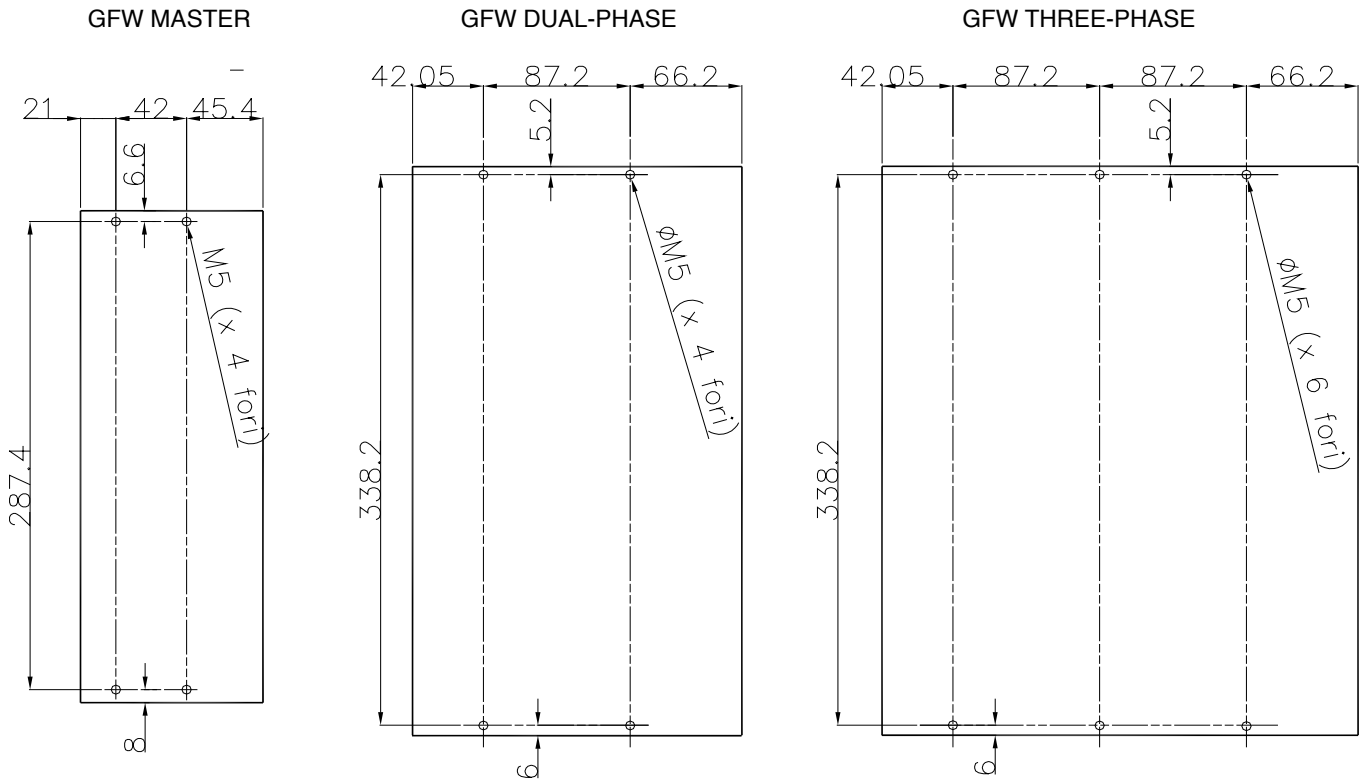
GFW THREE-PHASE (Master + 2 Expansions)



2.5 TEMPLATE DIMENSIONS

Figure 2

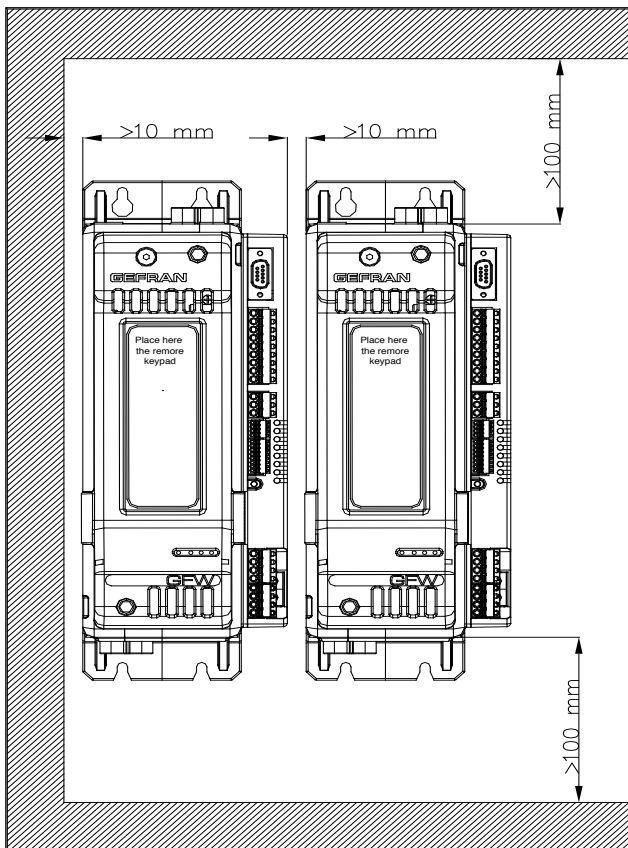
PANEL MOUNTING AND CUT-OUT DIMENSIONS



Fastening may be done with (5MA). All dimensions are expressed in mm.

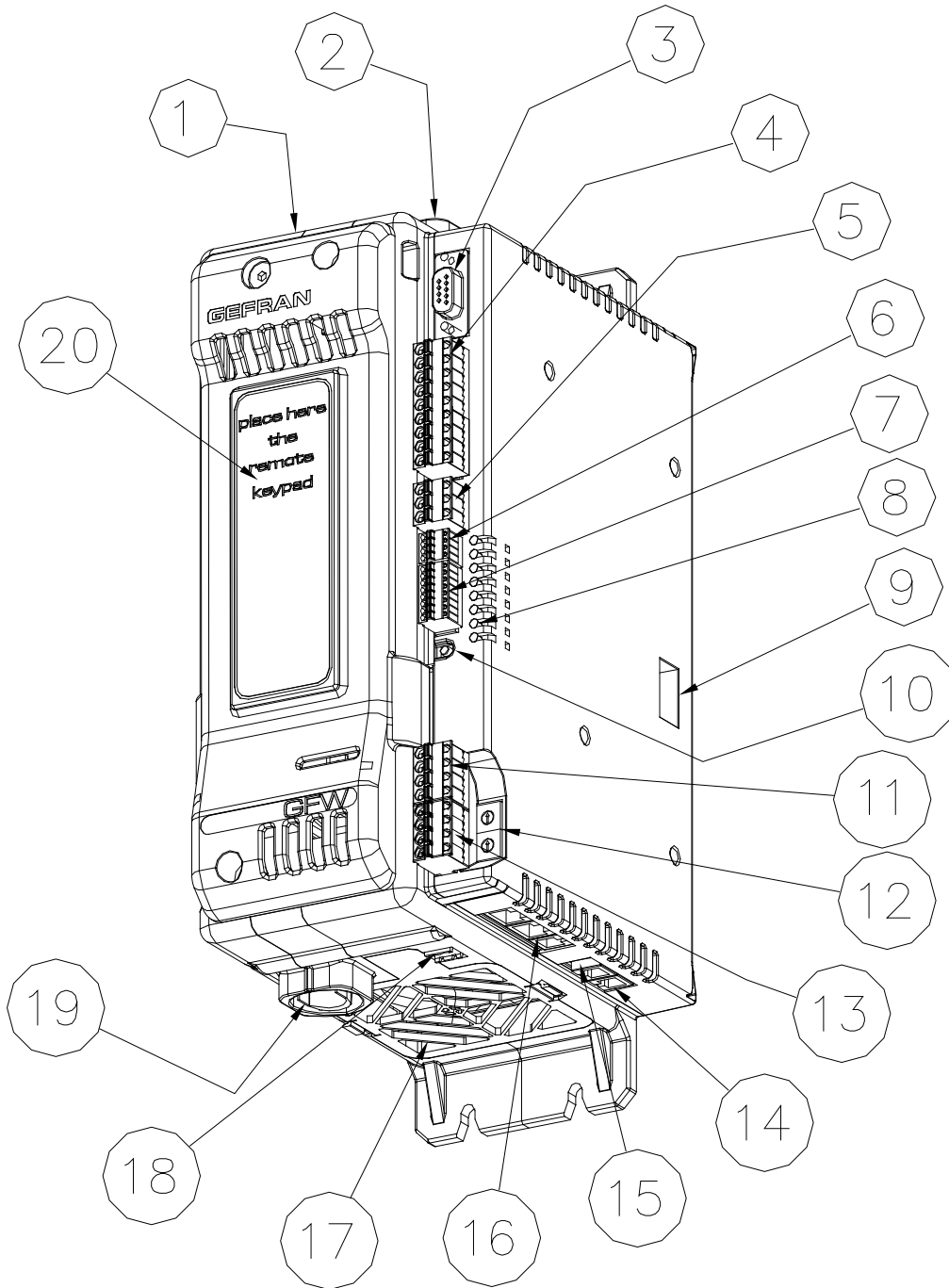
2.6 INSTALLATION

Figure 3



Attention: respect the minimum distances shown in figure 3 to provide adequate air circulation.

Figure 4



- | | | | |
|----|--------------------------------|----|--------------------------------------|
| 1 | Line / load voltage connector | 11 | Control input connector |
| 2 | "Line" terminals | 12 | Address Rotary Switch |
| 3 | Configuration keypad connector | 13 | input connector PID |
| 4 | Output connector | 14 | RJ10 connector serial RS485 (PORT 1) |
| 5 | Supply connector | 15 | Dip Switch serial line (PORT 1) |
| 6 | Digital input connector | 16 | Connector board Fieldbus (PORT 2) |
| 7 | 4 input TCAUX connector | 17 | Cooling Fan |
| 8 | Led | 18 | 24V fan connector power supply |
| 9 | Configuration Dip Switch | 19 | "Load" terminal |
| 10 | HB Key calibration | 20 | Internal fuse protection cover |

⚠ PERIODIC CLEANING

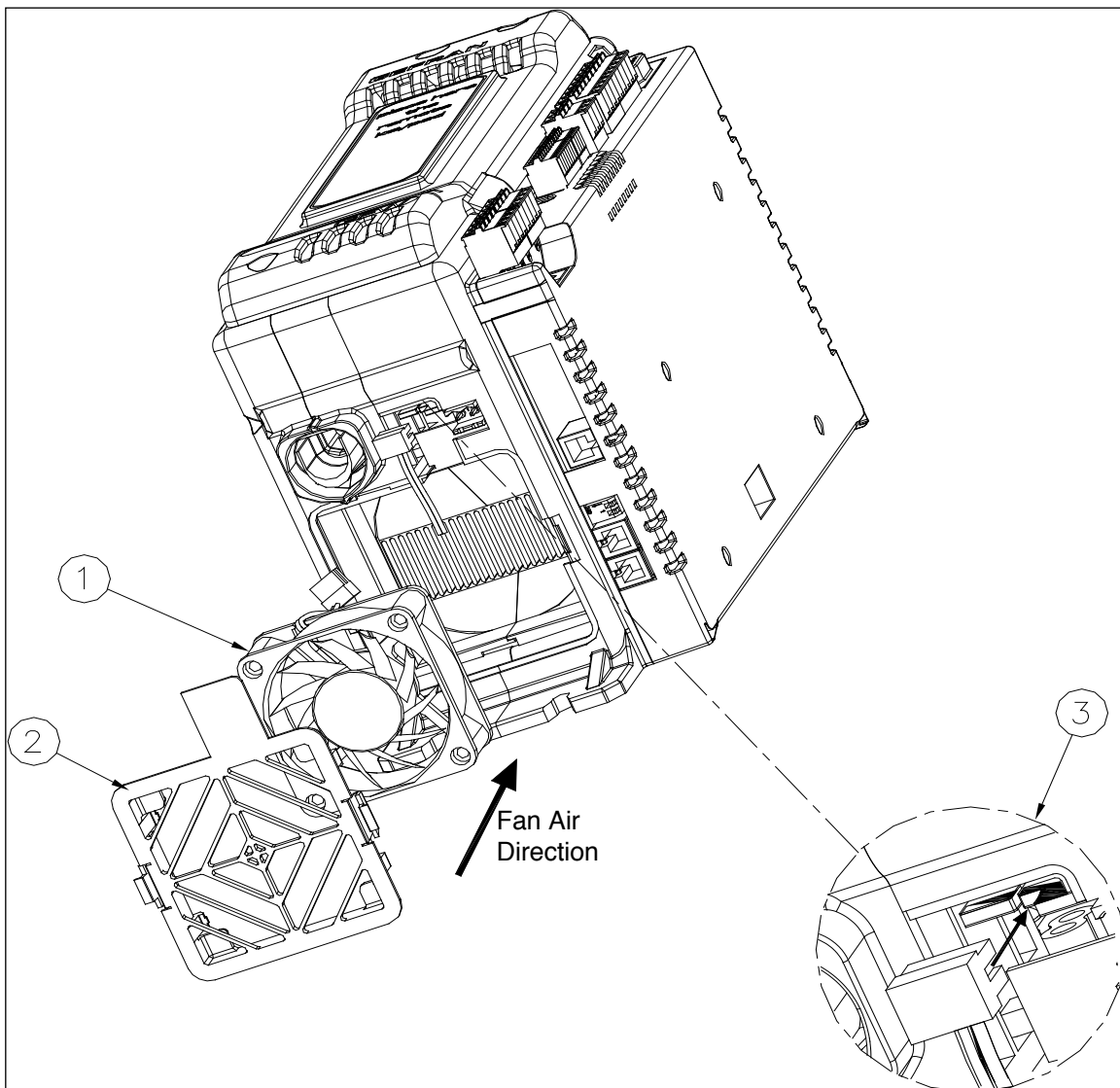
Every 6-12 months (depending on the dust level of the installation) blow a compressed air jet downward through the upper rectangular cooling grilles (on the side opposite the fan). This will clean the internal heat dissipater and the cooling fan.

⚠ IN CASE OF OVERHEAT ALARM

If periodic cleaning does not eliminate the problem, do as follows:

- a Remove the fan support grille by detaching the two support tabs
- b Disconnect the fan connector from the board
- c Check the condition of the fan
- d Clean or replace the fan
Attention: check that the arrow (on the fan) indicating the direction of air flow is pointing to the heat sink
- e Insert the connector into the board
- f Insert the fan support grille until it attaches
- g Power up the device and check fan rotation when at least one load is on

Figure 5



- 1. Fan
- 2. Lower grille (ventilation intake)
- 3. Detail of insertion of fan connector in PCB

2.9 REPLACING THE INTERNAL FUSE (OPTIONAL)

⚠ CUT OFF POWER BEFORE AND DURING FUSE SUBSTITUTION PROCEDURE

- Undo the cover fastening screw (1)
- Remove the cover following the movement indicated by the arrow (2)
- In this way the fuse is discovered (3)
- Loosen the two fastening nuts of fuse by means of tube-shaped spanner N.13 (GFW 40-150)
- It is not necessary to remove the nuts as the fuse N.17 (GFW 200-250A) is slipped off its seat by turning it (4) and extracting it (5) as indicated by the arrows
- Insert the new fuse as indicated by the arrows (6,7)

WARNING: the washer must stay between the nut and the fuse (NOT under the fuse).

- Fasten the two nuts by the 3-4 Nm torque tube-shaped spanner N. 13 (GFW 40-150), tube-shaped spanner N17 (GFW 200- 250A)
- Replace the cover pointing it to the lower part (pay attention to the connection tooth)
- Fasten the cover by the specific screw in side (1)

Figure 6

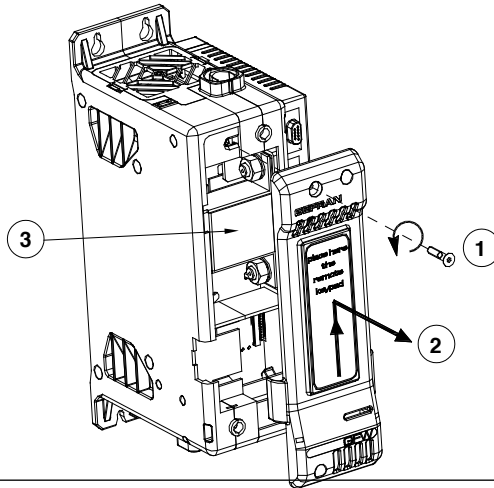


Figure 7

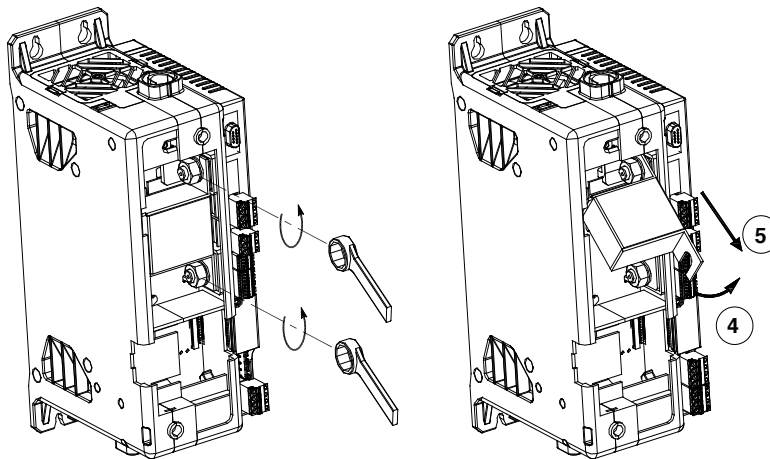
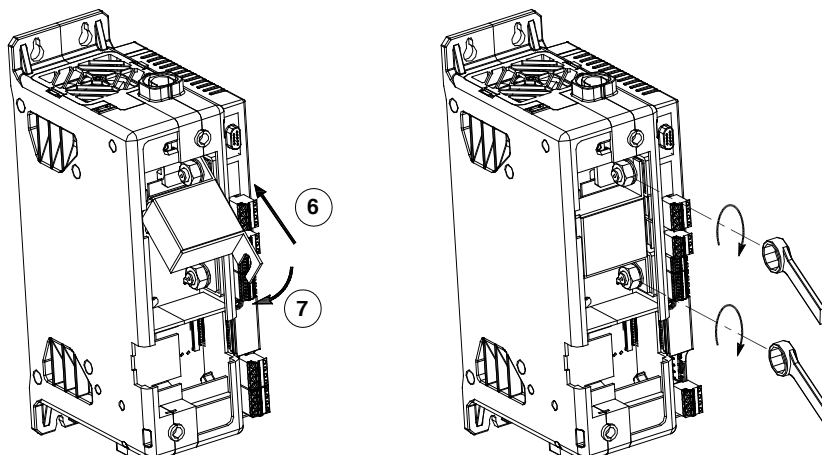


Figure 8



2.10 CARD INSERTION FOR FIELDBUS INTERFACE

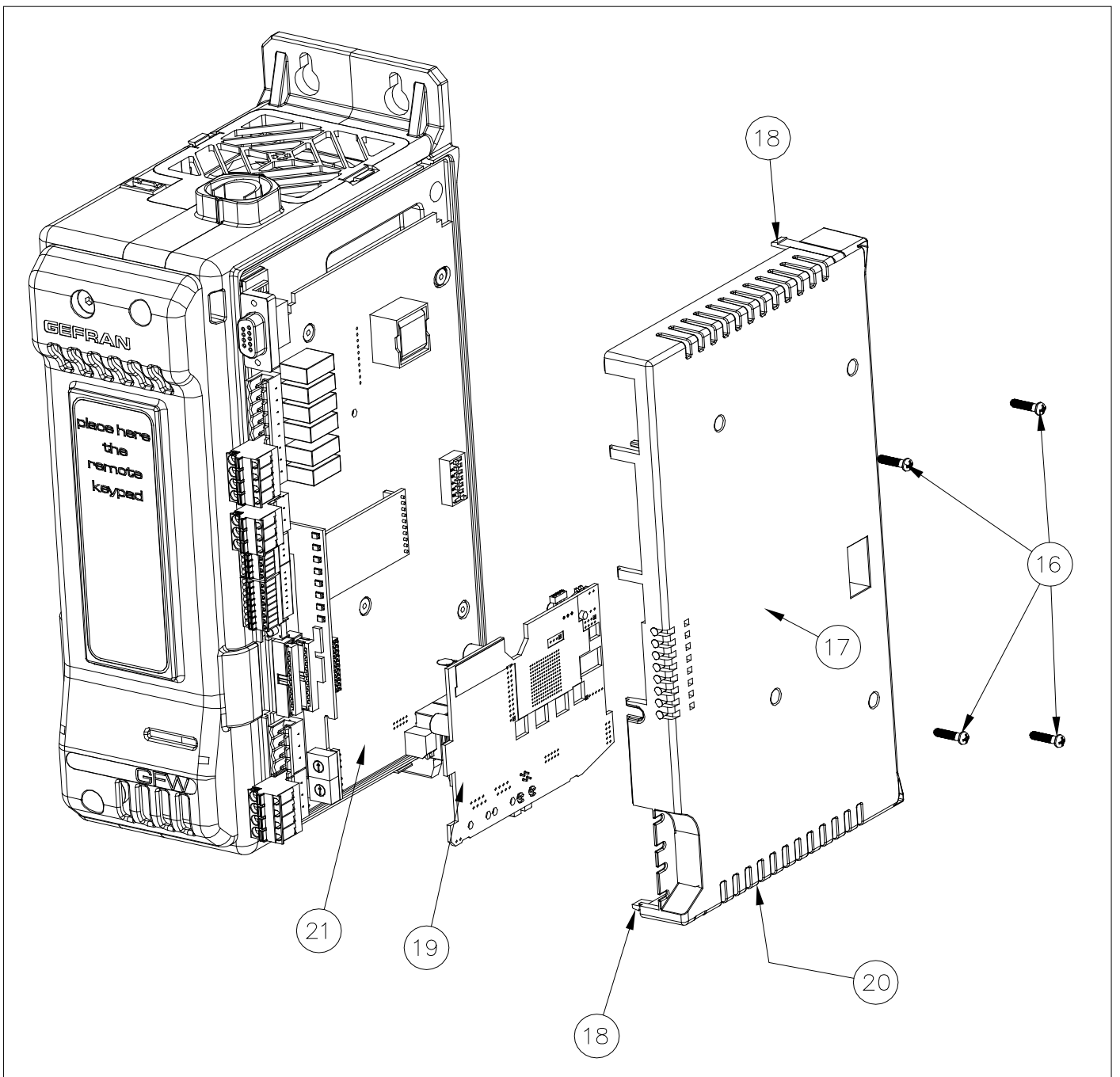
DO AS FOLLOWS:

- a. Undo the screws 16
- b. Turn slightly the points 18 using a screwdriver
- c. Remove the cover 17
- d. Place the interface card 19 in the connectors prepared on card 21
- e. Remove the pre-formed blanks parts 20 on cover 17 according to the type of interface installed
- f. Replace cover 17 in its seat
- g. Fasten the screws 16

WARNING:

Use ESD guards to avoid to damage the internal HW with electrostatic discharges.

Figure 9

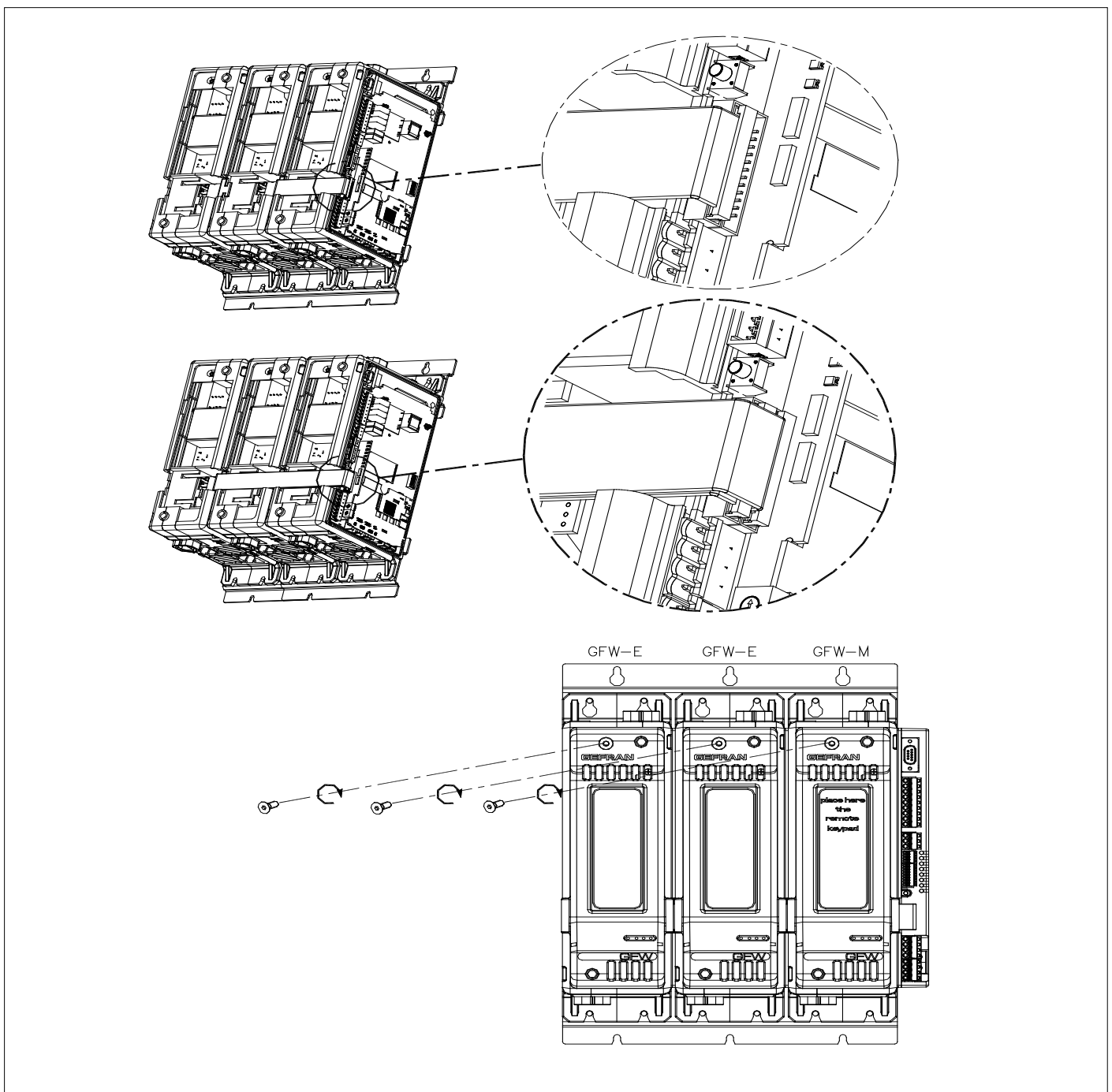


2.11 CONNECTION OF EXPANSION MODULES (FOR BIPHASE OR TRIPHASE CONFIGURATION)

CARRY OUT THE FOLLOWING STEPS:

- a. Remove the master module side cover by undoing the fastening screws
- b. Connect the flat cables supplied with the expansions to CPU card by inserting them into the appropriate connectors.
- c. Fix the side cover of the master with the specific screws
- d. Remove the front cover of the expansion modules undoing the fastening screw of the cover and correctly install the master module and the expansion module to the panel as described at paragraph 2.4.
- e. Fasten the screw to secure the product in position.
- f. Connect the two flat cables from the CPU card by inserting them into the correct connector of expansion.
- g. The cables flat already are inserted in the indicated connector of the expansion
- h. Do not pull the flat cable to avoid to damage it.
- i. Place the flat cable into the product and close the front cover of expansions.
- j. Check the front covers are properly closed with the screws.

Figure 10



3 · ELECTRICAL CONNECTIONS

3.1 POWER CONNECTIONS

GFW 40-250A

RECOMMENDED WIRE GAUGES

GFW CURRENT LEVEL	TERMINAL	WIRE GAUGE	TERMINAL TYPE	TIGHTENING / TOOL TORQUE
40A	1/L1, 2/T1	10 mm ² 7 AWG	Wire stripped for 25 mm or with crimped pre-insulated terminal tube CEMBRE PKC1018	5 Nm / Flat-head screwdriver tip 1 x 5.5 mm
60A	1/L1, 2/T1	16 mm ² 5 AWG	Wire stripped for 25 mm or with crimped pre-insulated terminal tube CEMBRE PKC1618	5 Nm / Flat-head screwdriver tip 1 x 5.5 mm
100A	1/L1, 2/T1,	35 mm ² 2 AWG	Wire stripped for 25 mm or with crimped pre-insulated terminal tube CEMBRE PKC35025	5 Nm / Flat-head screwdriver tip 1 x 5.5 mm
150A	1/L1, 2/T1	70 mm ² 2/0 AWG	Wire stripped for 25 mm or with crimped pre-insulated terminal tube CEMBRE PKC70022	6 Nm / No. 6 hex head wrench
200A	1/L1, 2/T1	95 mm ² 4/0 AWG	Wire stripped for 25 mm or with crimped pre-insulated terminal tube CEMBRE PKC95025	6 Nm / No. 6 hex head wrench
250A	1/L1, 2/T1	120 mm ² 250 AWG	Wire stripped for 25 mm	6 Nm / No. 6 hex head wrench
---	3/L2 (Ref. Vline) 4/T2 (Ref. Vload)	0.25 ...2.5 mm ² 23...14 AWG	Wire stripped for 8 mm or with tag terminal	0.5 ... 0.6 Nm / Flat-head screwdriver tip 0,6 x 3.5 mm

Note: Cables must be copper "Stranded Wire" or "Compact-Stranded Wire" type with maximum operating temperature 60/75°C

3.2 FUNCTIONS OF INDICATOR LEDS

Table 4 Description of LEDs



Led	Description	color
RN	Run - flashing during normal operation	green
ER	Error state: activates in case of error	red
	Lo = the process variable value is < Lo.S	
	HI = the process variable value is > Hi.S	
	Sbr = interrupted sensor or input values over maximum limits	
	Err = Pt100 short circuit and input value below minimum limit	
DI1	State digital input 1	yellow
DI2	State digital input 2	yellow
O1	State output Out 1	yellow
O2	State output Out 2, only with Expansion1 connected	yellow
O3	State output Out 3, only with Expansion2 connected	yellow
BUTTON	State HB key	yellow

Leds State

LED status refers to the corresponding parameter, with the following special cases:

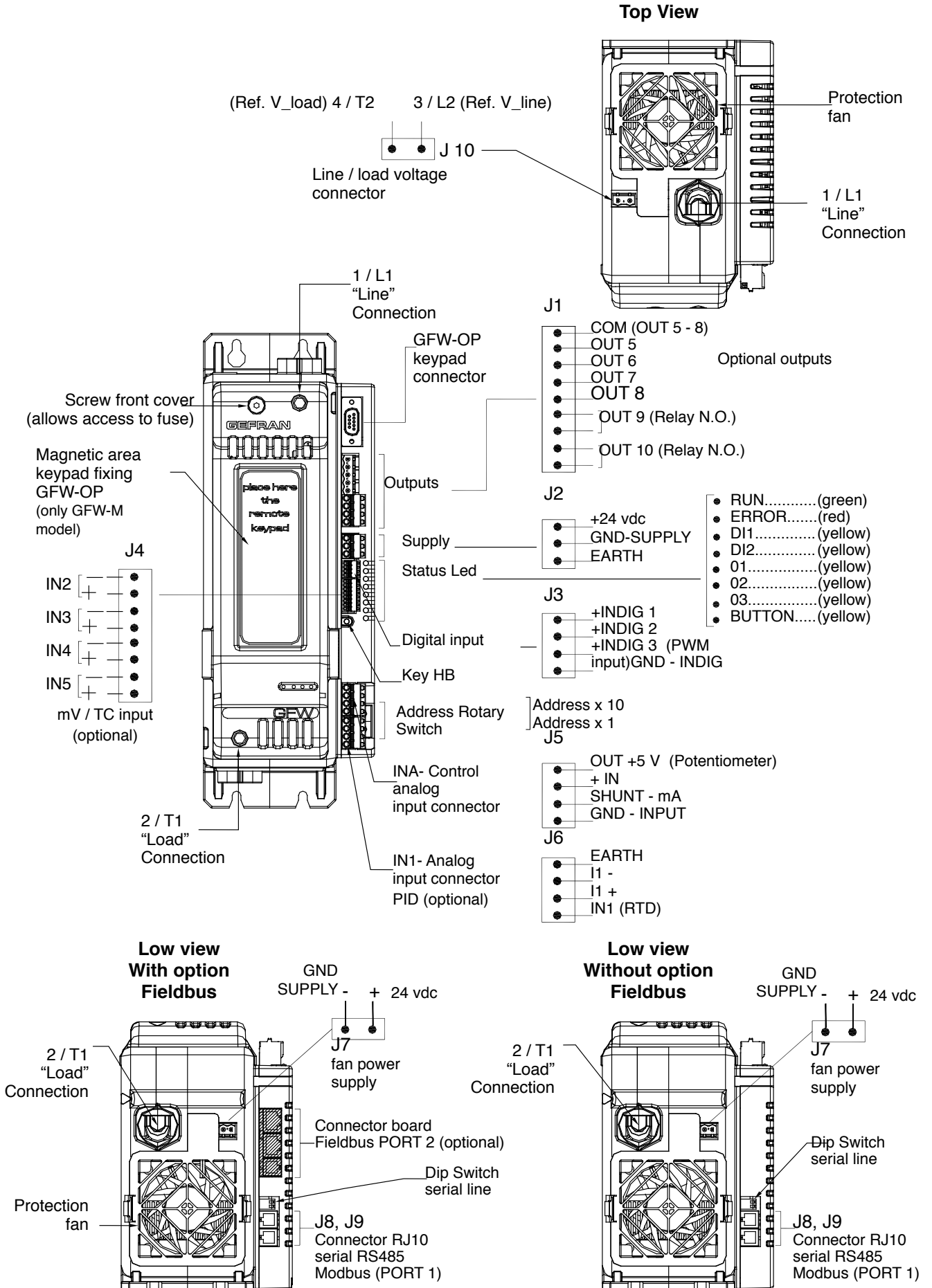
- LED RN (green) on: hotkey functionality
- LED RN (green) + LED ER (red) both flashing rapidly: autobaud in progress
- LED ER (red) on: error in one of main inputs (Lo, Hi, Err, Sbr)
- LED ER (red) flashing: temperature alarm ((OVER_HEAT or TEMPERATURE_SENSOR_BROKEN) or alarm of SHORT_CIRCUIT_CURRENT or SSR_SAFETY or FUSE_OPEN (only for singlephase configuration).
- LED ER (red) + LED Ox (yellow) both flashing: HB alarm or POWER_FAIL in zone x
- All LEDs flashing rapidly: ROTATION123 alarm (only for threephase configuration)
- All LEDs flashing rapidly except LED DI1: jumper configuration not provided
- All LEDs flashing rapidly except LED DI2: 30%_UNBALANCED_ERROR alarm (only for threephase configuration)
- All LEDs flashing rapidly except LED O1: SHORT_CIRCUIT_CURRENT alarm (only for threephase configuration)
- All LEDs flashing rapidly except LED O2: TRIPHASE_MISSING_LINE_ERROR alarm (only for threephase configuration)
- All LEDs flashing rapidly except LED O3: SSR_SAFETY alarm (only for threephase configuration)
- All LEDs flashing rapidly except LED BUTTON: FUSE_OPEN alarm (only for threephase configuration)

Table 5 Description of Rotary Switches

Switch	Description
 <p>x10</p>  <p>x1</p>	<p>Defines address of module 00...99 (in case of GFX compatible mode (dip switch 7= ON), this address is attributed to the GFW-M module; the expansions, if present, will have address +1 (GFW-E1) and address +2 (GFW-E2)) Hexadecimal combinations are reserved.</p>

3.3 DESCRIPTION INPUT/OUTPUT

Figure 11



3.4 CONNECTOR J1 OUTPUTS 5...10

If auxiliary outputs (O5...O8), are present, connector J1a becomes J1.

Figure 12 Connector J1

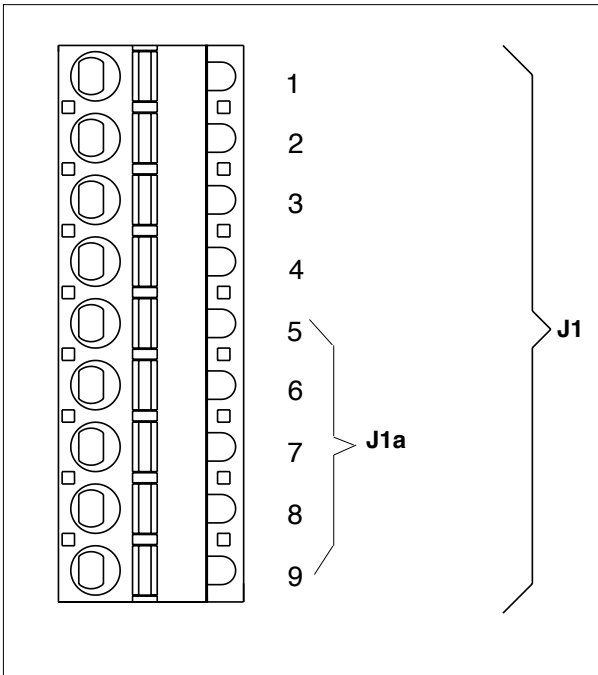


Table 6

	0,2 - 2,5mm ²	24-14AWG
	0,25 - 2,5mm ²	23-14AWG

Outputs 5...8 logic/continuous type

Logic outputs 18...36Vdc, max 20mA

Continuous outputs: voltage (default) 0/2...10V, max 25mA
current 0/4...20mA, max 500Ω

Figure 13 Connection scheme for logic/continuous outputs

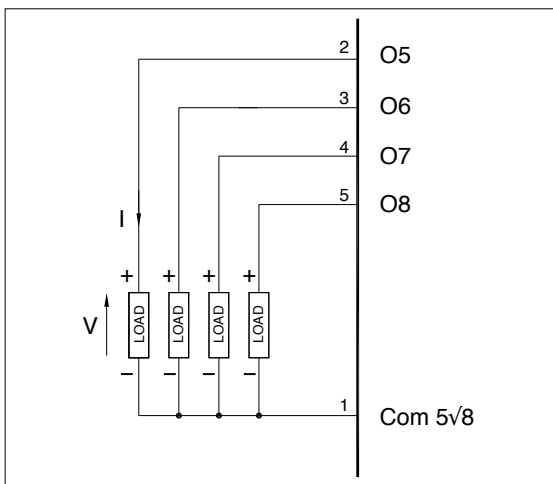
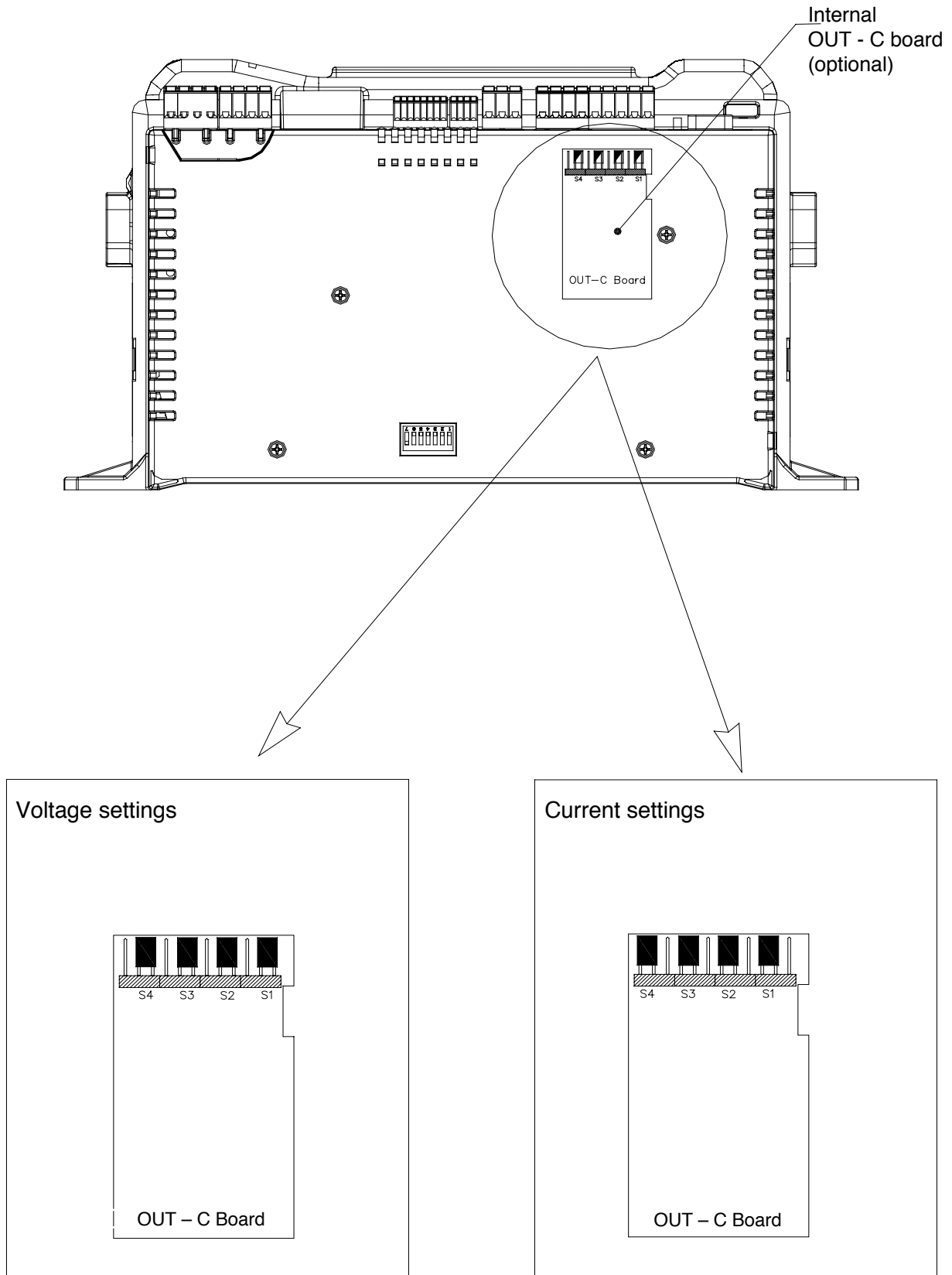


Table 7

PIN	Name	Description	
		Logic	Continuous
1	Com 5-8	Outputs common	(-)
2	O5	Output 5	(+)
3	O6	Output 6	(+)
4	O7	Output 7	(+)
5	O8	Output 8	(+)

When using the continuous “C” output option, voltage or current is set using jumper links on the board (Figure 14 refers).

Figure 14 Connection for logic/continuous utputs



Outputs 5...8 triac type

Triac outputs Vac = 24...230Vac, max 1A

Figure 15 Connection scheme for triac outputs

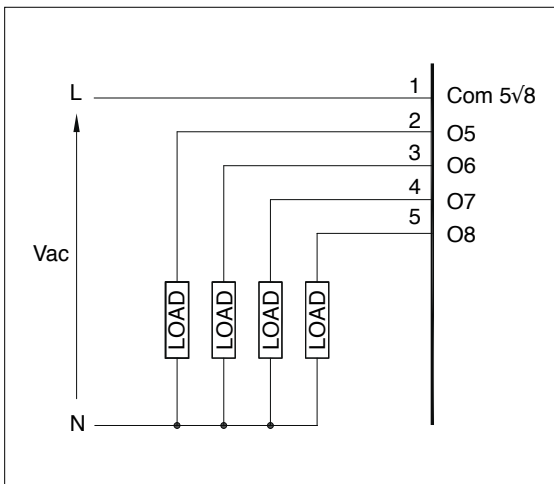


Table 8

PIN	Name	Description
1	Com 5-8	Outputs common
2	O5	Output 5
3	O6	Output 6
4	O7	Output 7
5	O8	Output 8

Outputs 5...8 relay type

Outputs Out 5...8 relay Ir = 3A max, NO

V = 250V/30Vdc cos φ = 1; I = 12A max

Figure 16 Connection scheme for relay outputs

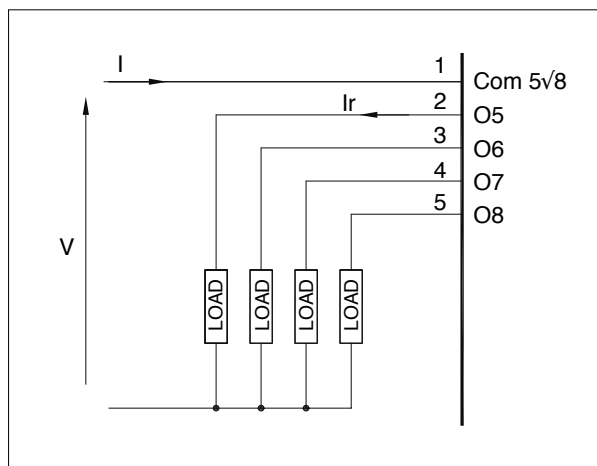


Table 9

PIN	Name	Description
1	Com 5-8	Outputs common
2	O5	Output 5
3	O6	Output 6
4	O7	Output 7
5	O8	Output 8

Outputs 9, 10 relay type

Outputs Out 9, 10 relay 5A max,

V = 250V/30Vdc cos φ = 1; I = 5A max

Figure 17 Connection scheme for relay outputs

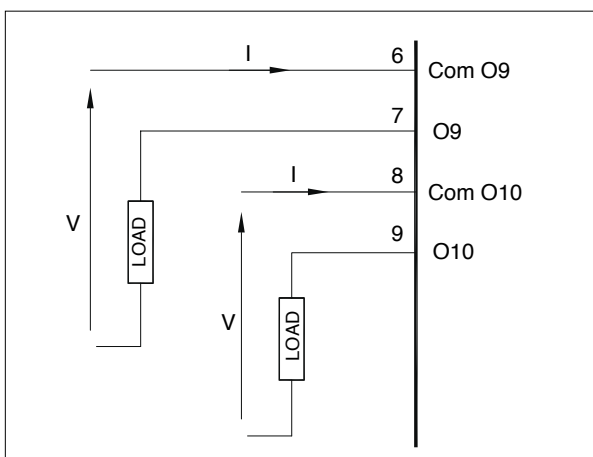


Table 10

PIN	Name	Description
1	Com O9	Output common O9
2	O9	Output O9
3	Com O10	Output common O10
4	O10	Output O10

3.5 CONNECTOR J2 POWER SUPPLY

Figure 18

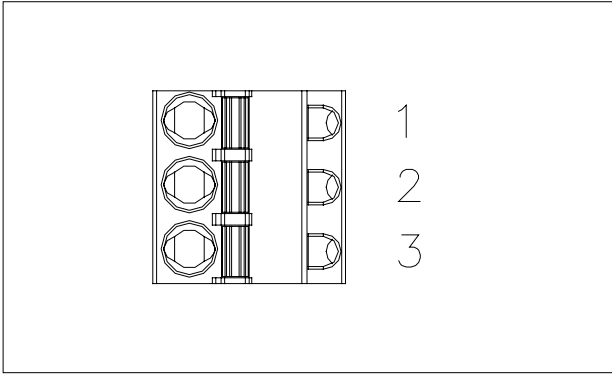


Figure 19

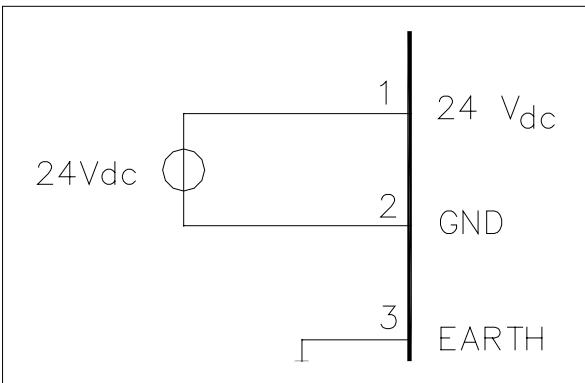


Table 11





	0,2 - 2,5mm ²	24-14AWG
		
	0,25 - 2,5mm ²	23-14AWG
		

Table 12

PIN	Name	Description
1	+24 Vdc	24V Supply
2	GND	
3	EARTH	Ground EMC

3.6 CONNECTOR J2 DIGITAL INPUT

Figure 20

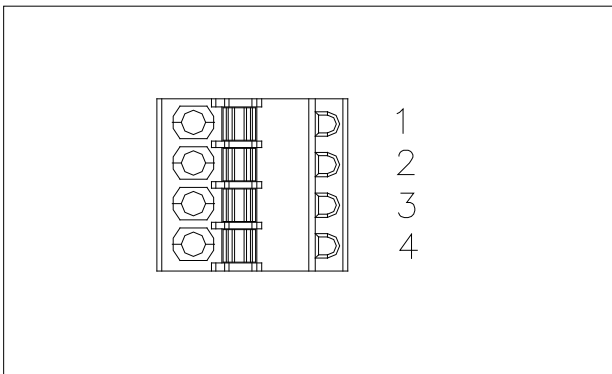


Table 13

	0,14 - 0,5mm ²	28-20AWG
		
	0,25 - 0,5mm ²	23-20AWG
		

Figure 21 Connection scheme for digital inputs

see paragraph "(PWM) digital input"

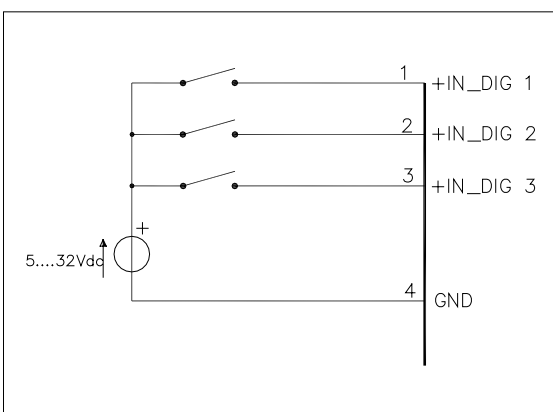


Table 14

PIN	Name	Description
1	+INDIG1	Digital Input 1 (5...32Vdc)
2	+INDIG2	Digital Input 2 (5...32Vdc)
3	+INDIG3	Digital Input 3 (5...32Vdc)
4	GND	GND common

Figure 22

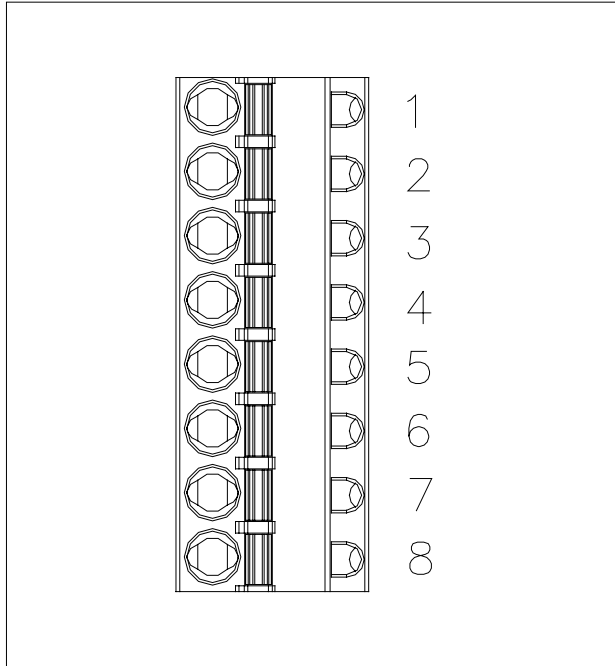


Table 15




	0,14 - 0,5mm ²	28-20AWG
		
	0,25 - 0,5mm ²	23-20AWG

Figure 23 Auxiliary inputs I5 - I8 (60mV/TC)

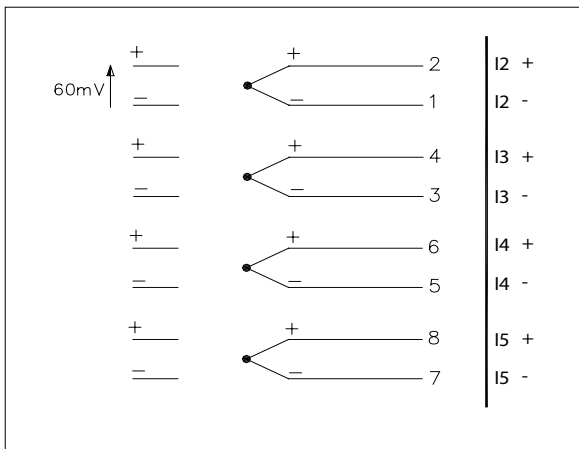


Table 16

PIN	Name	Description
1	I2-	Auxiliary input 2
2	I2+	
3	I3-	Auxiliary input 3
4	I3+	
5	I4-	Auxiliary input 4
6	I4+	
7	I5-	Auxiliary input 5
8	I5+	

Figure 24

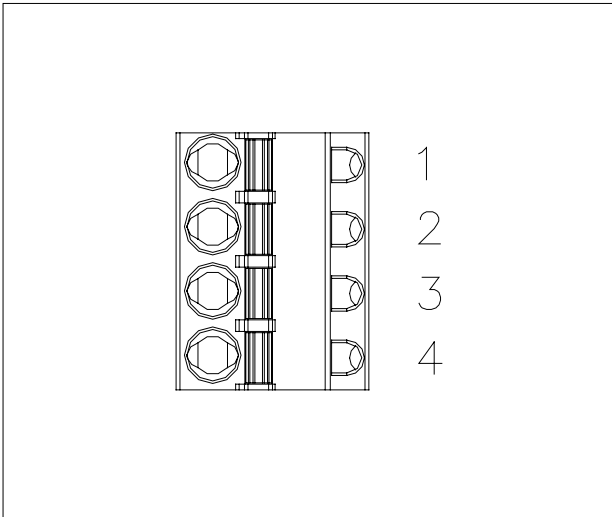


Table 17

	0,2 - 2,5mm ²	24-14AWG
	0,25 - 2,5mm ²	23-14AWG

Figure 25 Connection scheme

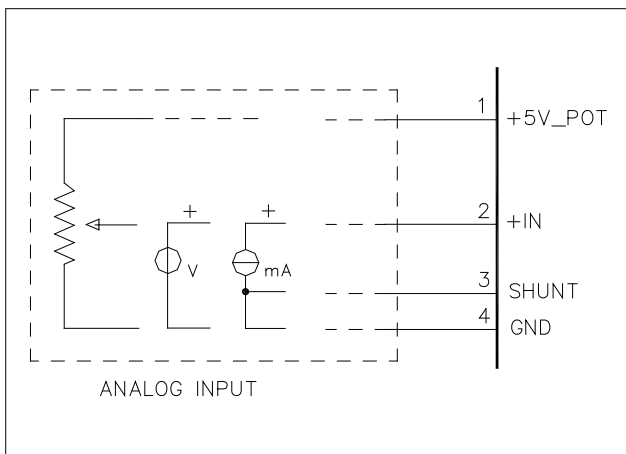


Table 18

PIN	Name	Description
1	+5V_Out	Supply output 5V potentiometer
2	+IN	Control voltage Input
3	SHUNT	Shunt for input mA
4	GND	GND control signal

Figura 26

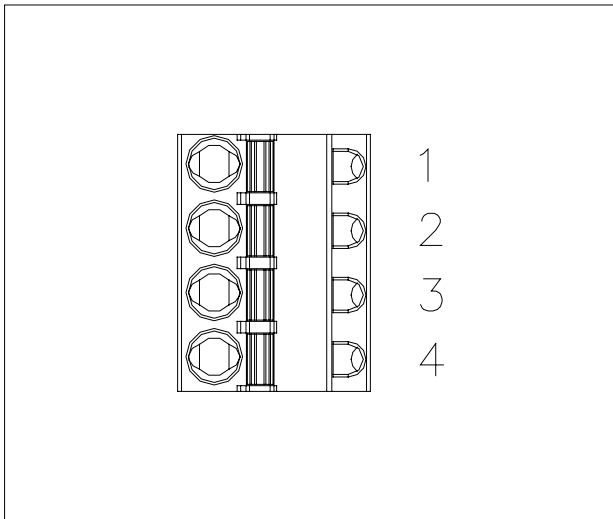


Table 19





	0,2 - 2,5mm ²	24-14AWG
		
	0,25 - 2,5mm ²	23-14AWG
		

Figure 27 Connection scheme for 60mV TC/linear input

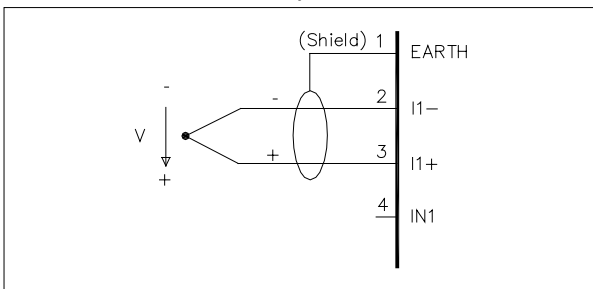


Figure 28 Connection scheme for Pt100 input

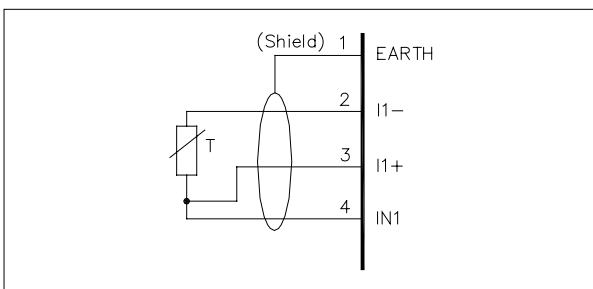


Table 20

PIN	Name	Description
1	EARTH	EMC earth (for shielded cable)
2	I1-	Negative Input
3	I1+	Positive Input TC and RTD
4	IN1	3rd Wire RTD, Positive IN mA,

Figure 29 Connection scheme for 1V/20mA linear input

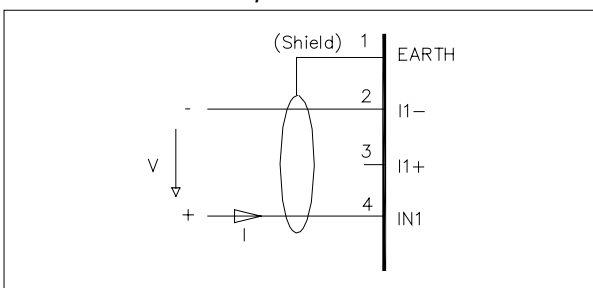


Table 21

PIN	Linear input 60mV/Tc	Linear input 1V/20mA	Input Pt100
1	(Wire Shield)	(Wire Shield)	(Wire Shield)
2	I1-	I1-	I1+
3	I1+	Not connected	I1+
4	Not connected	IN1 (+)	IN1

3.10 Description of dip-switches

Figure 30

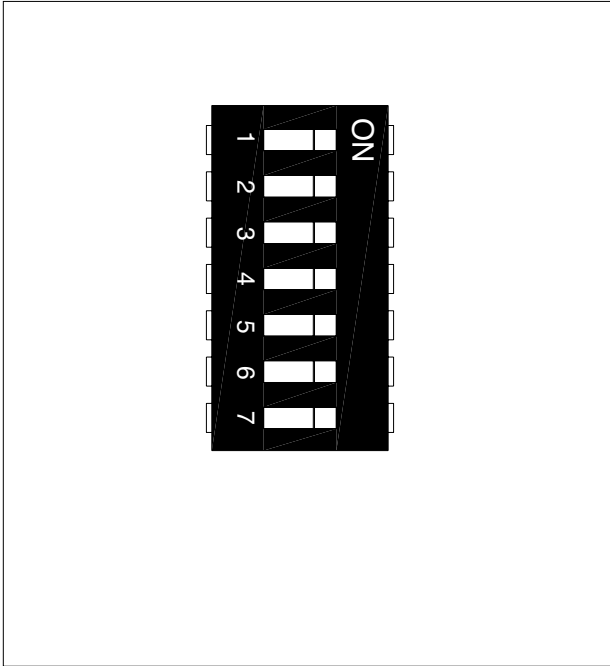


Table 22

dip-switches	Description
1	Connection type: (see table 23)
2	Connection type: (see table 23)
3	Connection type: (see table 23)
4	Connection type: (see table 23)
5	OFF = resistive load ON = inductive load (transformer primary control)
6	ON = reset factory configuration
7	ON = Geflex simulation function

Table 23

Dip 1	Dip 2	Dip 3	Dip 4	Dip 5	Connection type	Request modules		
						GFW master	GFW Expansion 1	GFW Expansion 2
				OFF : resistive load ON : inductive load (transformer primary control)				
OFF	OFF	OFF	OFF	OFF/ON	Three Single-phase load	x	(*)	(*)
OFF	ON	OFF	OFF	OFF/ON	Three Independent single-phase load in open delta	x	x	x
ON	ON	OFF	OFF	OFF/ON	3-phase load open delta/star load with neutral	x	x	x
ON	ON	ON	OFF	OFF/ON	3-phase load closed delta	x	x	x
ON	OFF	OFF	ON	OFF/ON	3-phase star load without neutral	x	x	x
ON	OFF	OFF	OFF	OFF	3-phase load with 2-phase command	x	x	

(*) Each expansion lets you add a single-phase load (up to a maximum of 3 total loads).

IMPORTANT!

AFTER SETTING THE REQUIRED DIP-SWITCH CONFIGURATION, RUN THE FOLLOWING PARAMETER INITIALIZATION PROCEDURE ONCE:

- CHECK THE CORRECT SETTING OF DIPS 1-2-3-4-5
- SET DIP 6 TO "ON" (FACTORY CONFIGURATION)
- POWER THE DEVICE WITH 24 VDC
- WAIT FOR CORRECT AND REGULAR FLASHING OF THE GREEN RUN LED
- SET DIP 6 TO "OFF"
- THE DEVICE IS CORRECTLY CONFIGURED

Port1 (local bus): Modbus serial interface – connectors S1, S2.

Figure 31

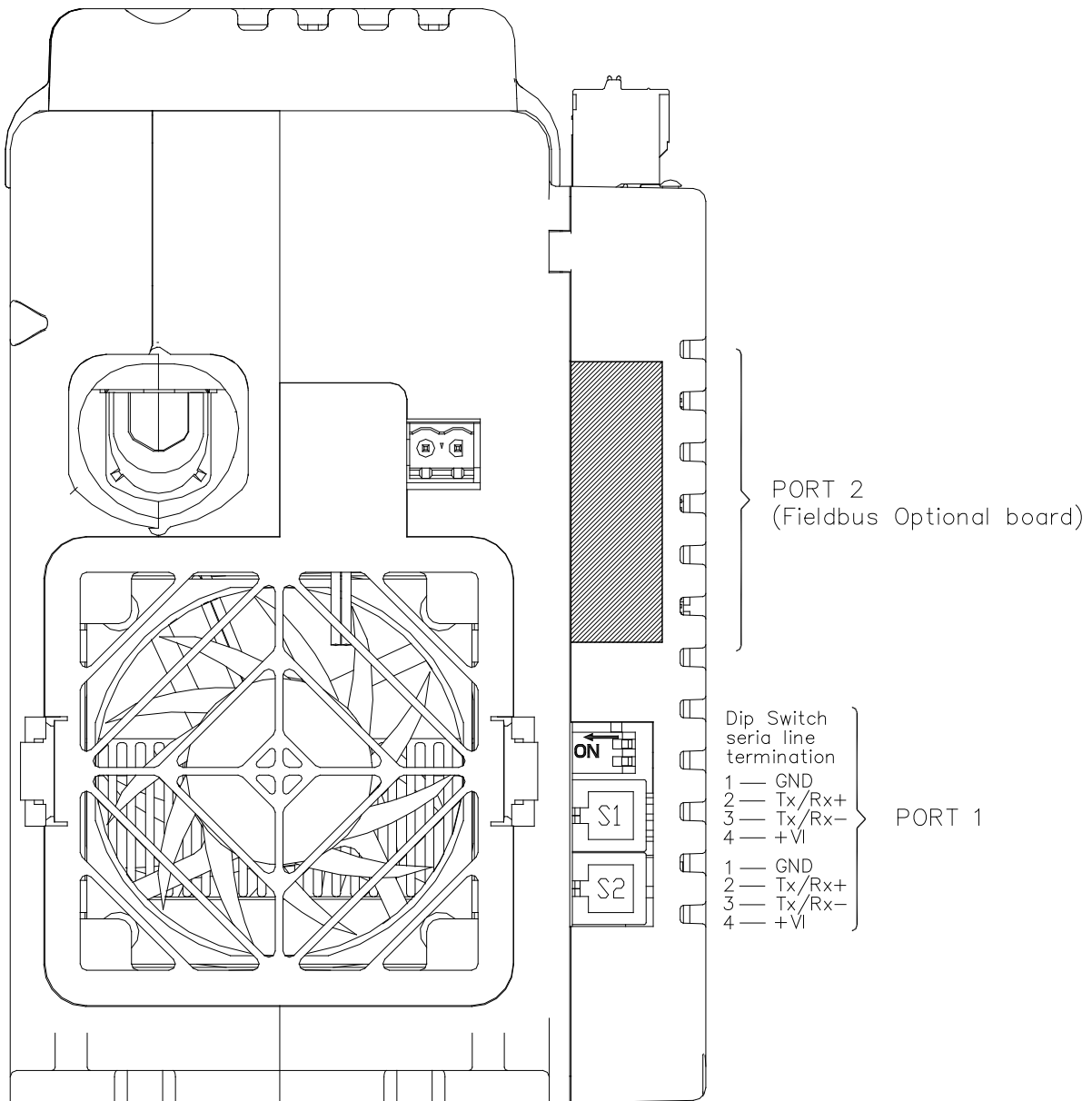


Table 24

Connector S1/S2 RJ10 4-4 pin	Nr. Pin	Name	Description	Note
	1	GND1 (**)	-	(*) Insert the RS485 line termination in the last device on the Modbus line, see dip-switches.
	2	Tx/Rx+	Data reception/transmission (A+)	
	3	Tx/Rx-	Data reception/transmission (B-)	
	4	+V (reserved)	-	
Cable type: flat telephone cable for pin 4-4 conductor 28AWG				(**) Connect the GND signal between Modbus devices with a line distance > 100 m.

Port2 (fieldbus): connectors S4, S5 MODBUS RTU/MODBUS RTU

Figure 32 Port2: Fieldbus Modbus RTU/Modbus RTU interface

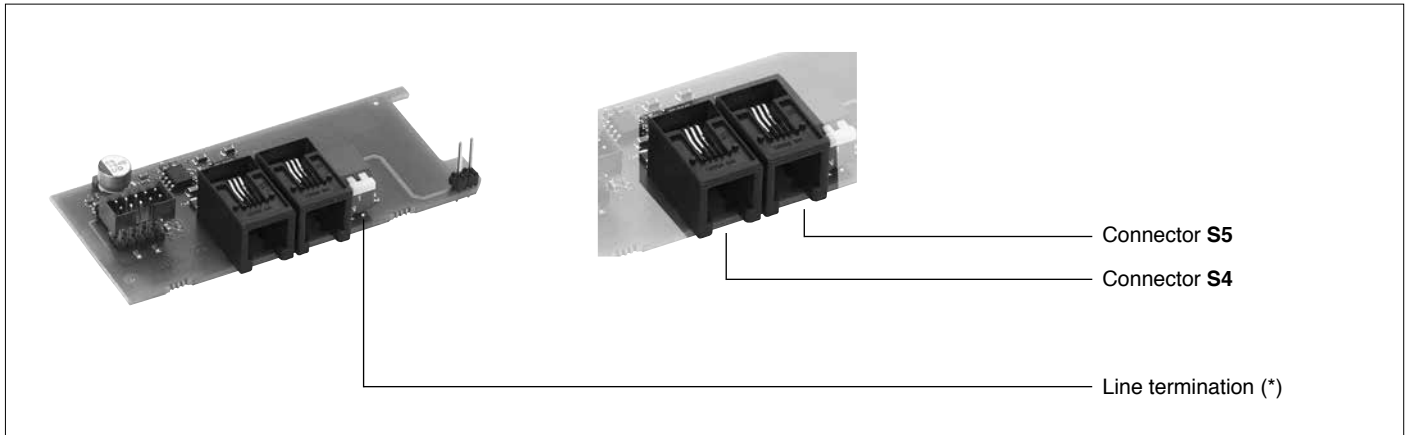
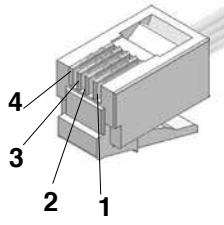


Table 25

Connector S4/S5 RJ10 4-4 pin	Nr. Pin	Name	Description	Note
	1	GND1 (**)	-	(*) Insert the line termination in the last device on the Modbus line.
	2	Tx/Rx+	Data reception/transmission (A+)	
	3	Tx/Rx-	Data reception/transmission (B-)	(**) Connect the GND signal between Modbus devices with a line distance > 100 m.
	4	+V (reserved)	-	

Cable type: flat telephone cable for pin 4-4 conductor 28AWG

Port2 (fieldbus): connectors S4, S5 MODBUS RTU/Profibus DP

Figure 33 Port2: Fieldbus Modbus RTU/Profibus DP interface

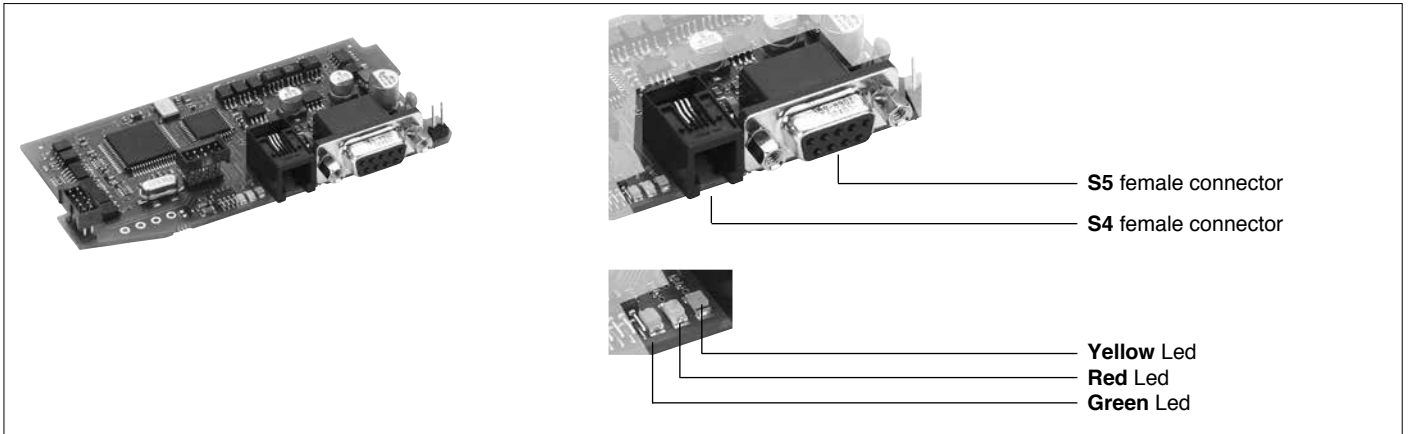


Table 26

Connector S4 RJ10 4-4 pin	Nr. Pin	Name	Description	Note
	1	GND1 (**)	-	(**) Connect the GND signal between Modbus devices with a line distance > 100 m.
	2	Rx/Tx+	Data reception/transmission (A+)	
	3	Rx/Tx-	Data reception/transmission (B-)	
	4	+V (reserved)	-	
Cable type: flat telephone cable for fin 4-4 conductor 28AWG				

Table 27

Connector S5 D-SUB 9 pins male	Nr. Pin	Name	Description	Note
	1	SHIELD	EMC protection	Connect the terminal resistances as shown in the figure.
	2	M24V	Output voltage - 24V	
	3	RxD/TxD-P	Data reception/transmission	
	4	n.c.	n.c.	
	5	DGND	Data Ground	
	6	VP	Positive power supply +5V	
	7	P24V	Output voltage +24V	
	8	RxD/TxD-N	Data reception/transmission	
	9	n.c.	n.c.	
Cable type: Shielded 1 pair 22AWG conforming to PROFIBUS.				

Port2 (fieldbus): connectors S4, S5 MODBUS RTU/CANopen

Figure 34 Port2: Fieldbus Modbus RTU/CANOpen interface

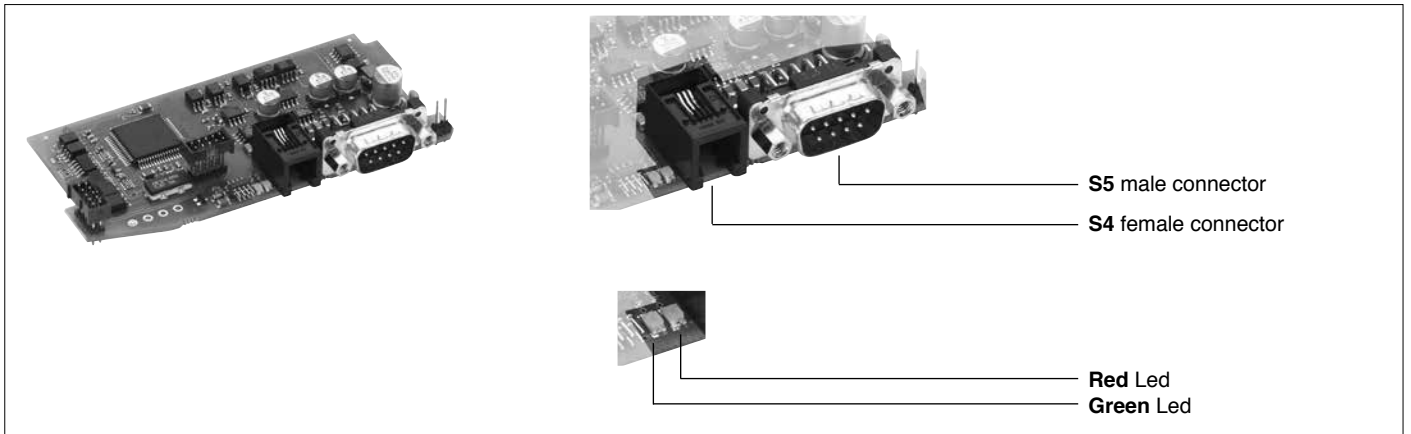


Table 28

Connector S4 RJ10 4-4 pin	Nr. Pin	Name	Description	Note
	1	GND1 (**)	-	(**) Connect the GND signal between Modbus devices with a line distance > 100 m.
	2	Rx/Tx+	Data reception/transmission (A+)	
	3	Rx/Tx-	Data reception/transmission (B-)	
	4	+V (reserved)	-	
Cable type: flat telephone cable for fin 4-4 conductor 28AWG				

Table 29

Connector S5 D-SUB 9 pins female	Nr. Pin	Name	Description	Note
	1	-	Reserved	Connect the terminal resistances as shown in the figure.
	2	CAN_L	CAN_L bus line (domination low)	
	3	CAN_GND	CAN Ground	
	4	-	Reserved	
	5	(CAN_SHLD)	Optional CAN Shield	
	6	(GND)	Optional Ground	
	7	CAN_H	CAN_H bus line (domination high)	
	8	-	Reserved	
	9	(CAN_V+)	Optional CAN external positive supply (dedicated for supply of transceiver and optocouplers, if galvanic isolation of the bus node applies)	
Cable type: Shielded 2 pairs 22/24AWG conforming to CANopen.				

Port2 (fieldbus): connectors S4, S5 Modbus RTU / Ethernet Modbus TCP

Figure 36 Port2: Modbus RTU / Ethernet Modbus TCP interface

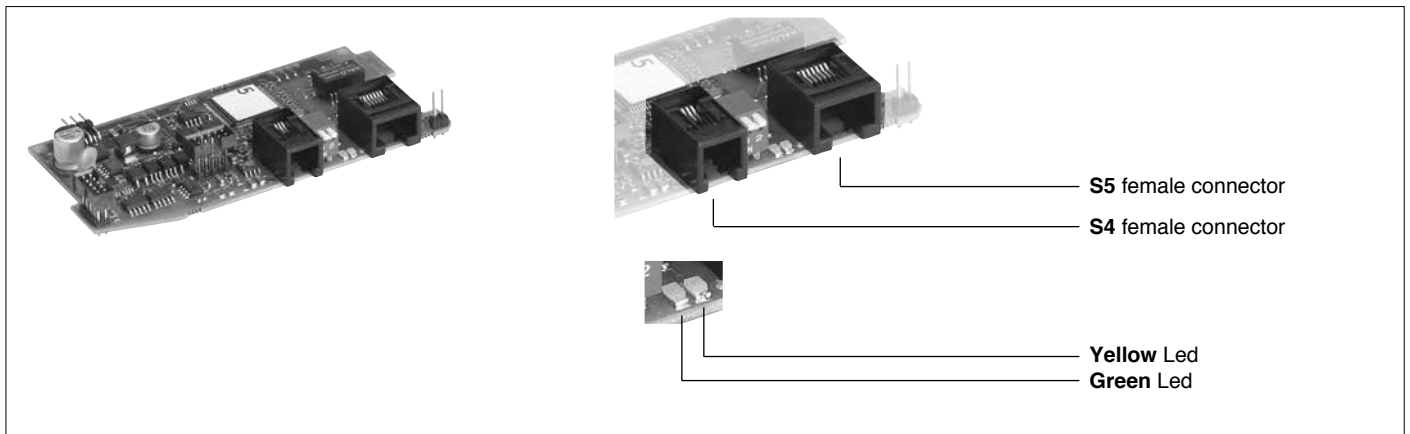


Table 32

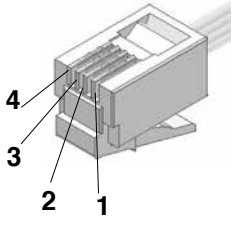
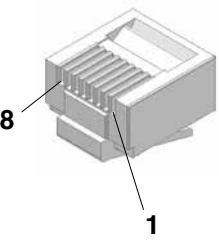
Connector S4 RJ10 4-4 pin	Nr. Pin	Name	Description	Note
	1	GND1 (**)	-	(**) Connect the GND signal between Modbus devices with a line distance > 100 m.
	2	Rx/Tx+	Data reception/transmission (A+)	
	3	Rx/Tx-	Data reception/transmission (B-)	
	4	+V (reserved)	-	
Cable type: flat telephone cable for pin 4-4 conductor 28AWG				

Table 33

Connector S5 RJ45	Nr. Pin	Name	Description	Note
	1	TX+	Data + transmission	
	2	TX-	Data - transmission	
	3	RX+	Data + reception	
	4	n.c.		
	5	n.c.		
	6	RX-	Data - reception	
	7	n.c.		
	8	n.c.		
Cable type: Use standard category 6 cable according to TIA/EIA-568A				

Port2 (fieldbus): connectors S4, S5 Modbus RTU / Ethernet IP or Modbus RTU / EtherCAT

Figure 38 Port2: Modbus RTU / Ethernet IP or Modbus RTU / EtherCAT

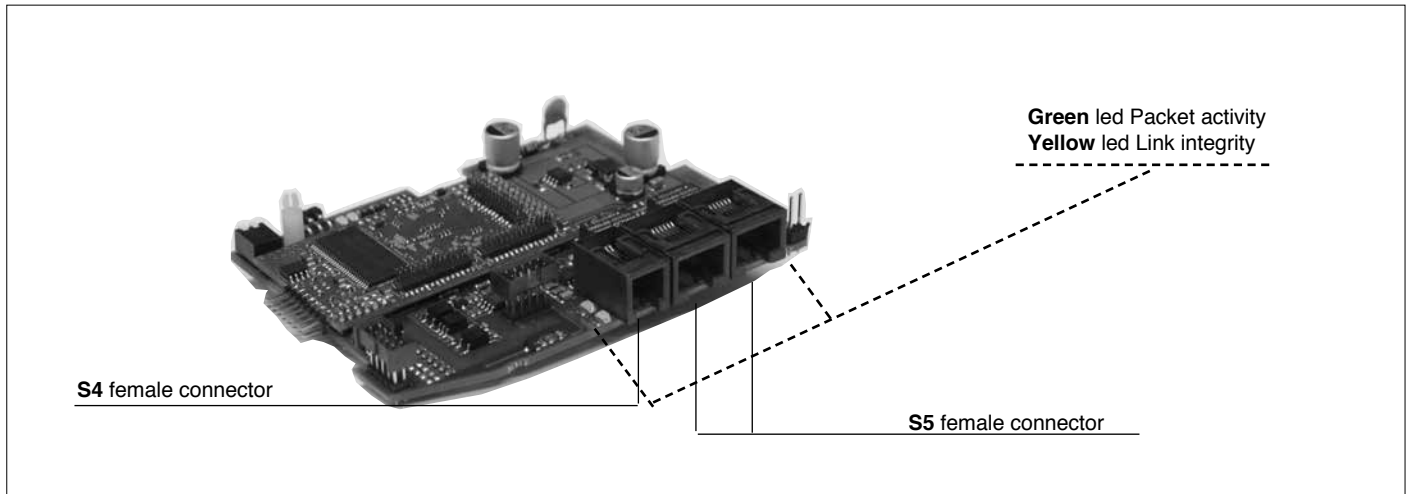


Table 36

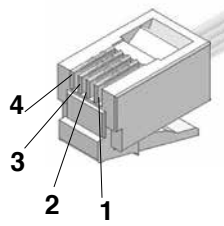
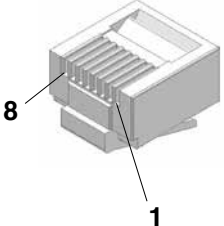
Connector S4 RJ10 4-4 pin	Nr. Pin	Name	Description	Note
	1	GND1 (**)	-	(**) Connect the GND signal between Modbus devices with a line distance > 100 m.
	2	Rx/Tx+	Data reception/transmission (A+)	
	3	Rx/Tx-	Data reception/transmission (B-)	
	4	+V (reserved)	-	
Cable type: flat telephone cable for pin 4-4 conductor 28AWG				

Table 37

Connector S5 RJ45	Nr. Pin	Name	Description	Note
	1	TX+	Data + transmission	
	2	TX-	Data - transmission	
	3	RX+	Data + reception	
	4	n.c.		
	5	n.c.		
	6	RX-	Data - reception	
	7	n.c.		
	8	n.c.		
Cable type: Use standard category 6 cable according to TIA/EIA-568A				

3.12 CONNECTION EXAMPLE: POWER SECTION

Figura 39 GFW connection example for 1 single-phase load

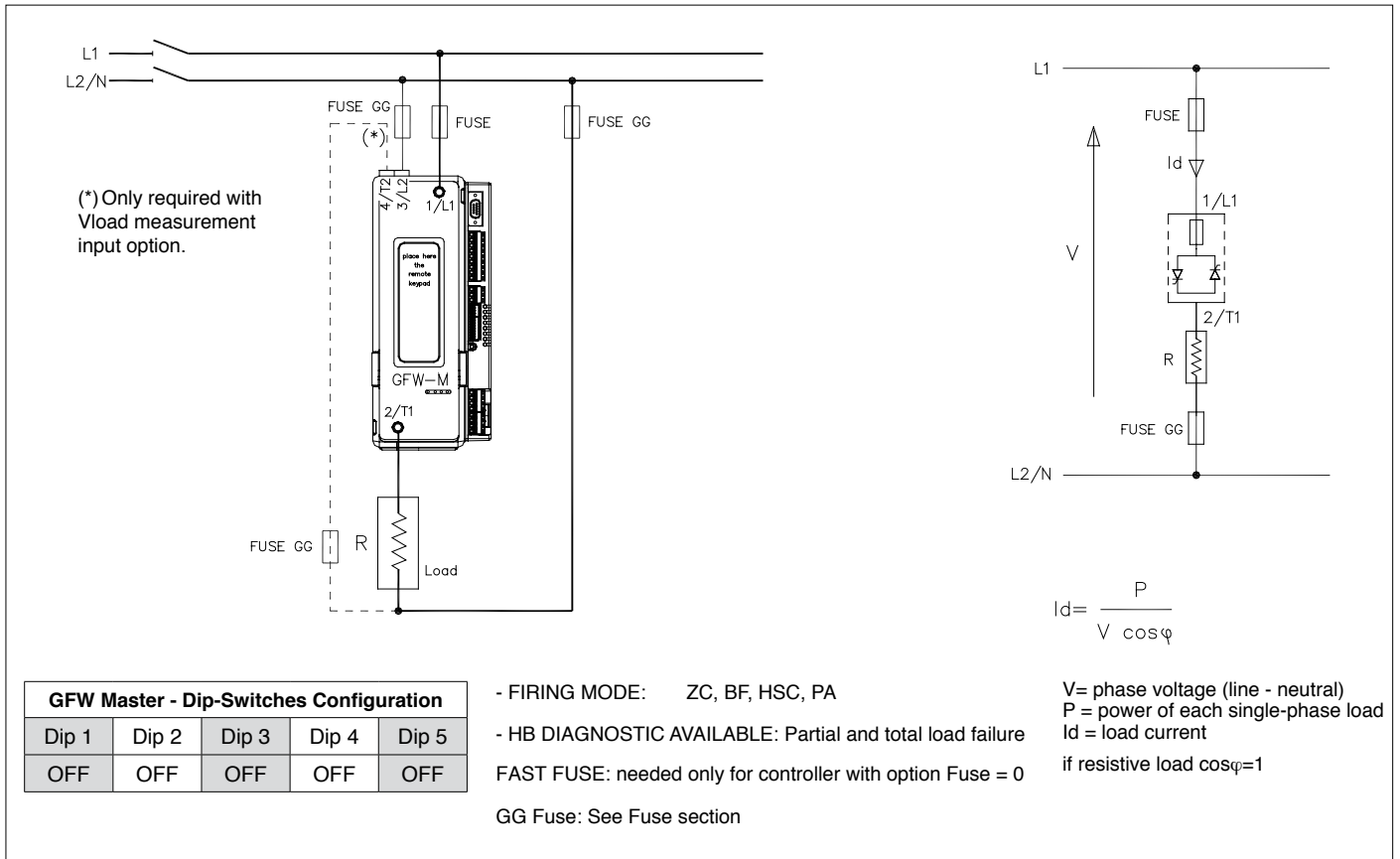


Figura 40 GFW connection example for 1 single-phase transformer load,

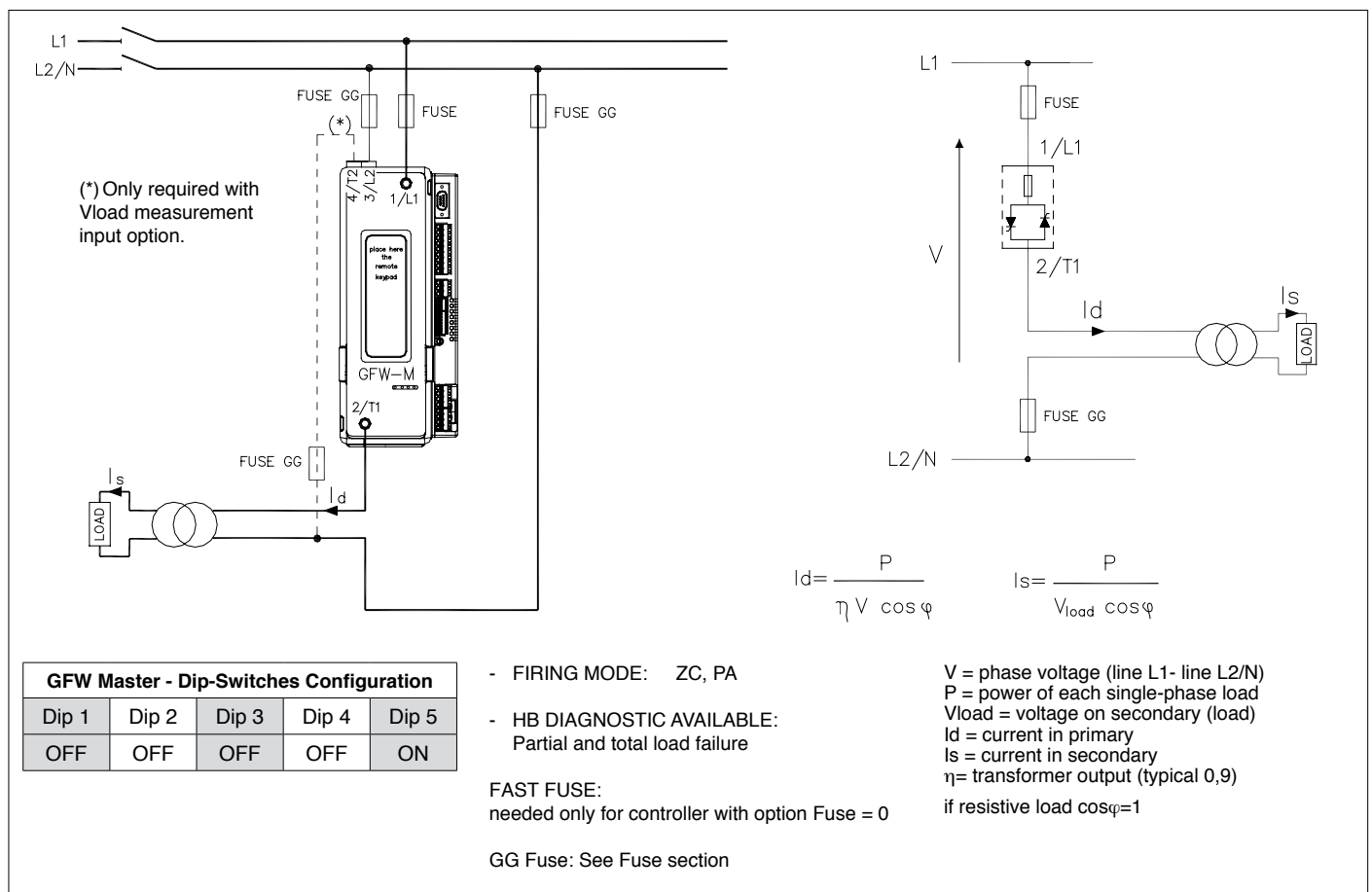


Figure 41a Sample GFW biphase connection for a triphase star load without neutral

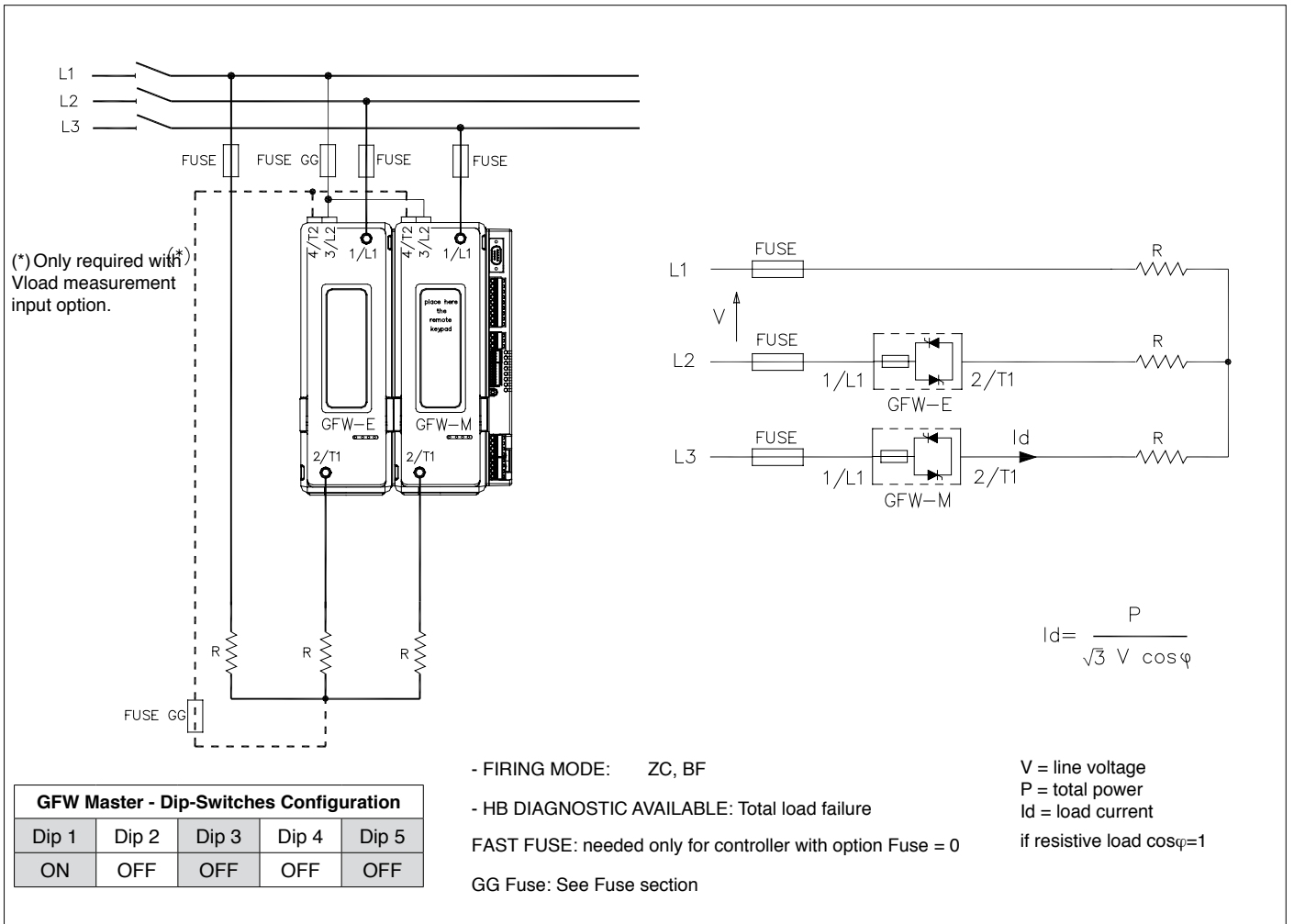


Figure 41b Sample GFW biphase connection for a triphase closed delta load

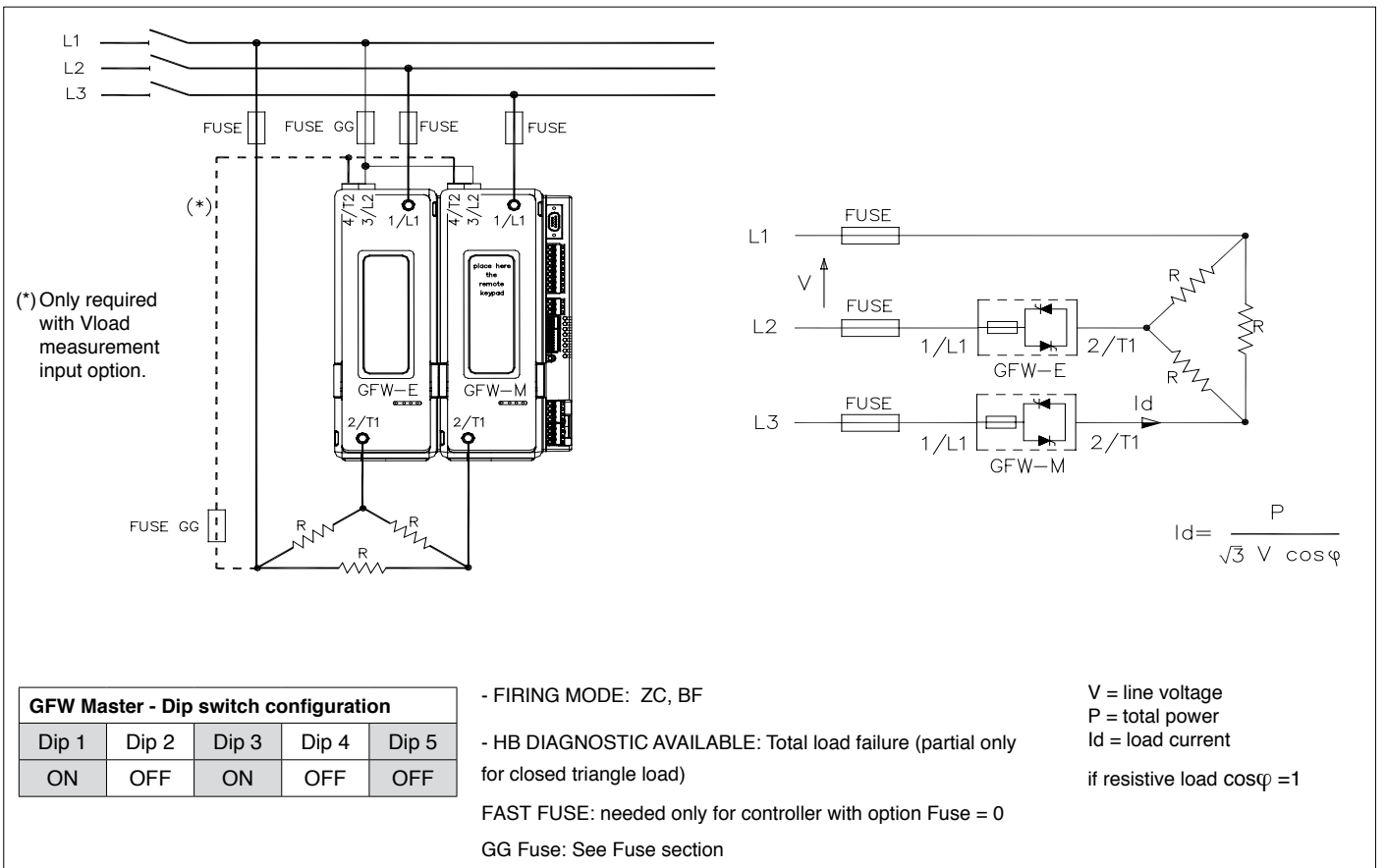


Figure 46 GFW connection example for 1 3-phase star load with neutral

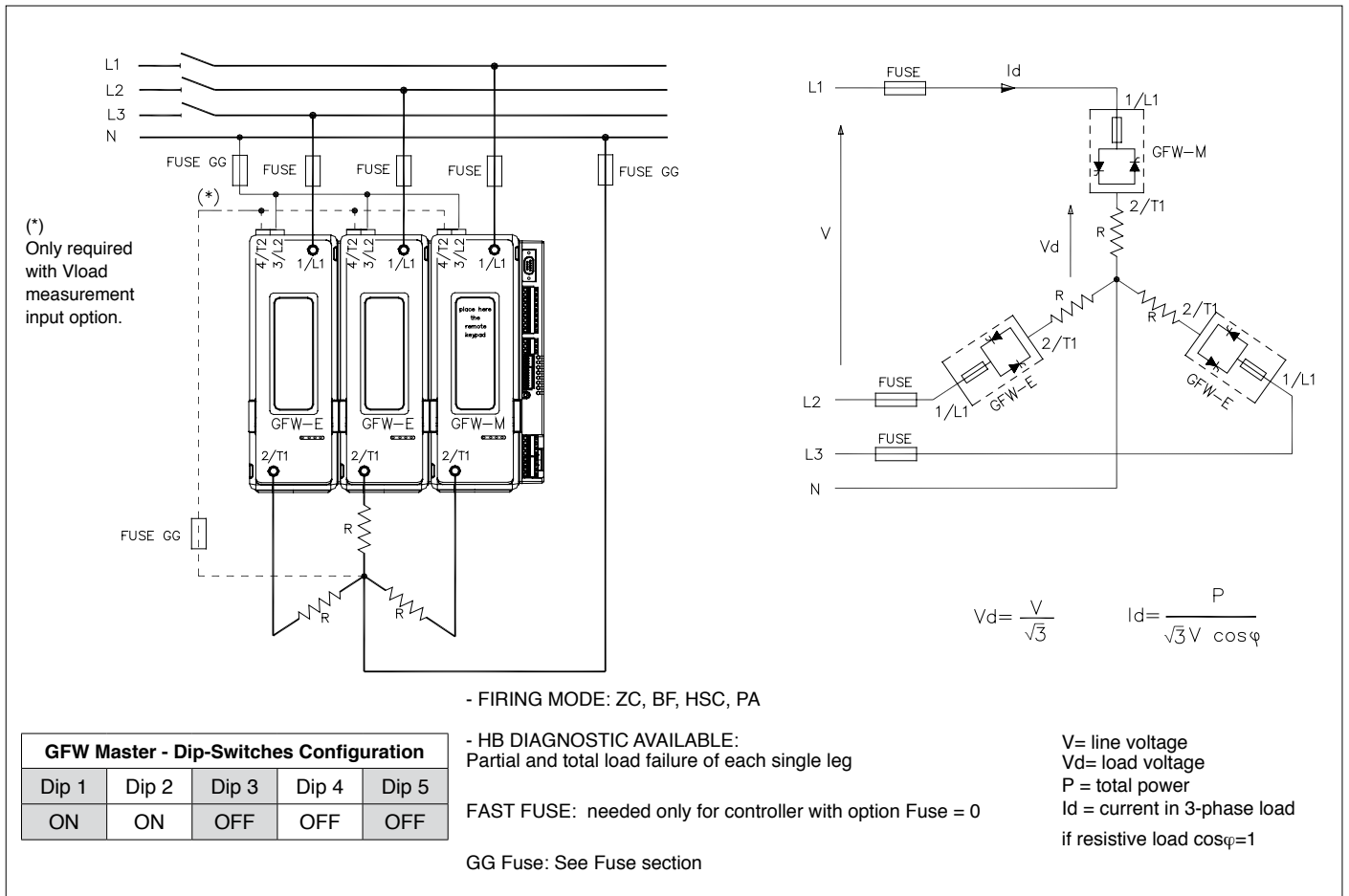


Figure 47 GFW connection example for 1 3-phase load open delta

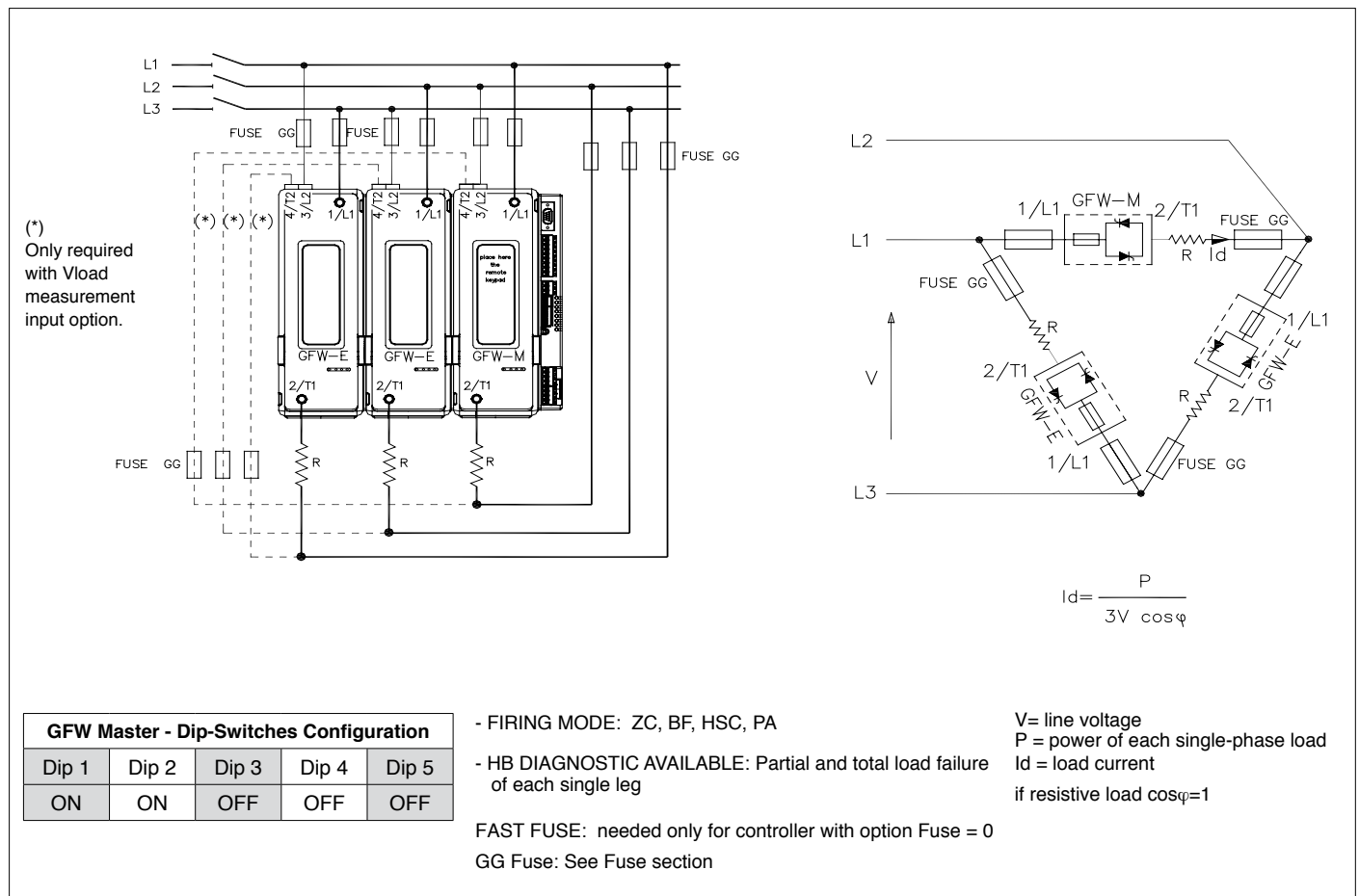


Figure 48 GFW connection example for 3 independent loads in open delta, 3-phase line without neutral

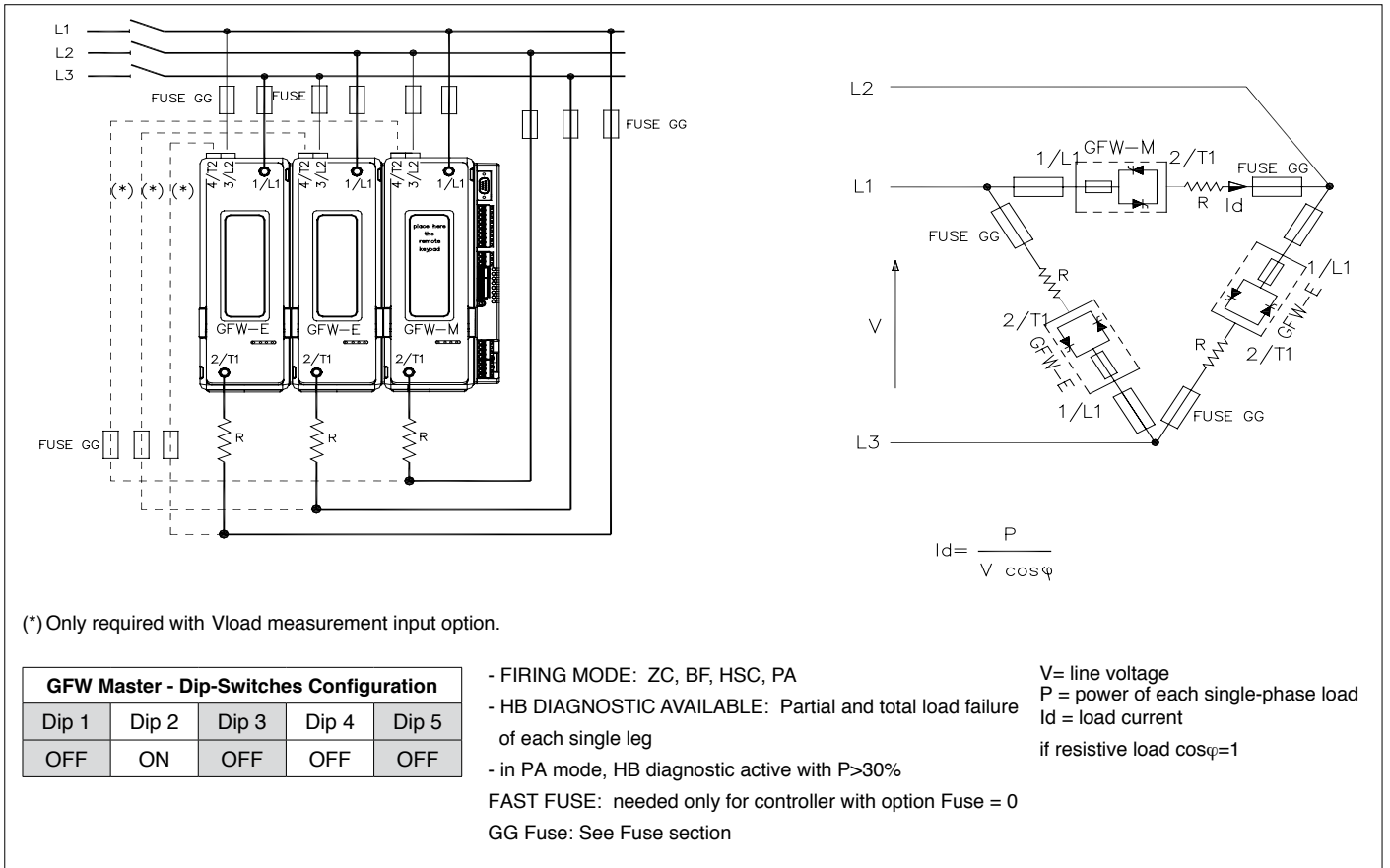


Figure 49 Example of GFW3-PH wiring for 3 independent single-phase loads

It is possible to connect three single-phase loads also to three different line voltages, between line to line or line to neutral. It is possible to manage by Fieldbus different power values for each one of the three loads.

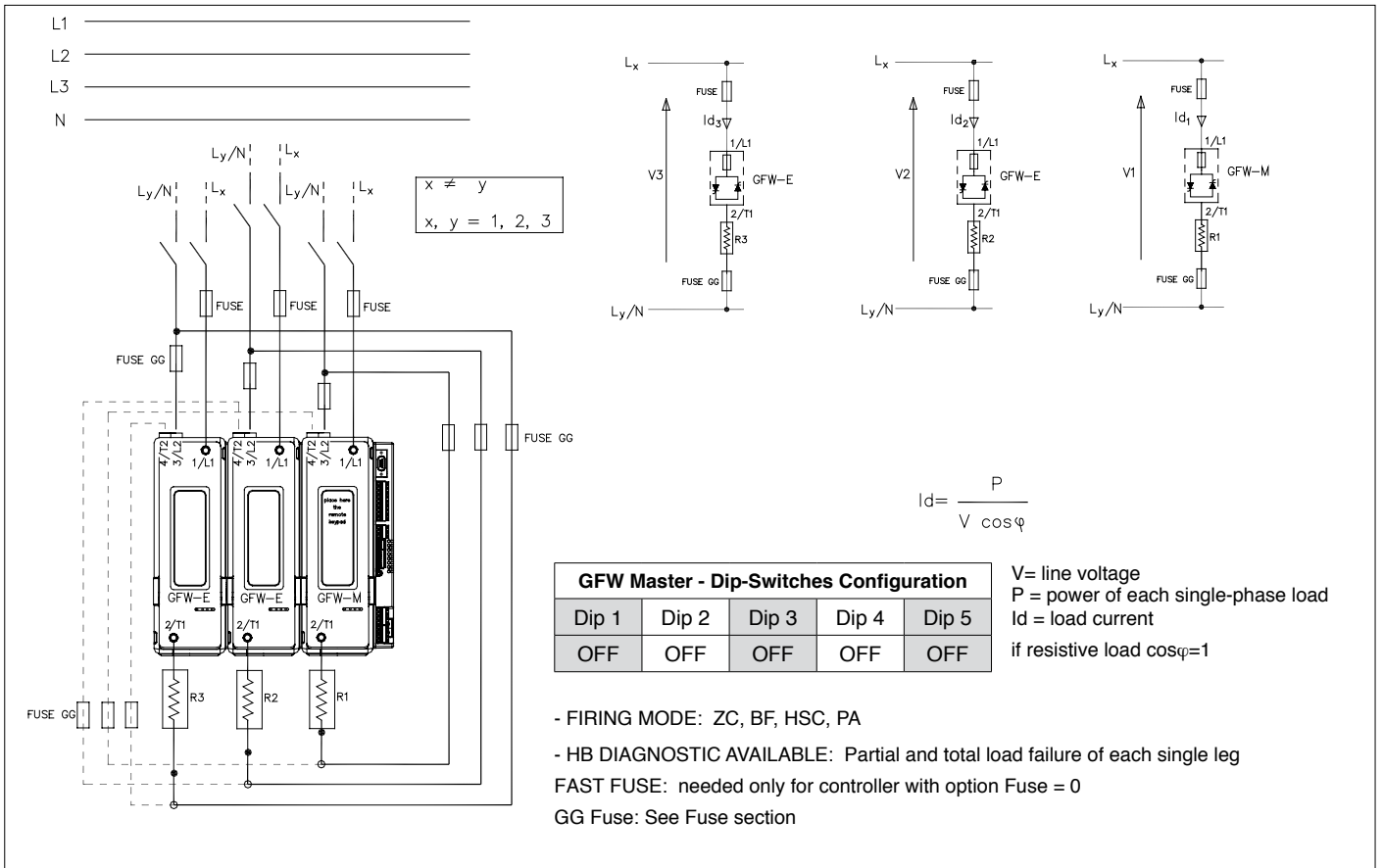
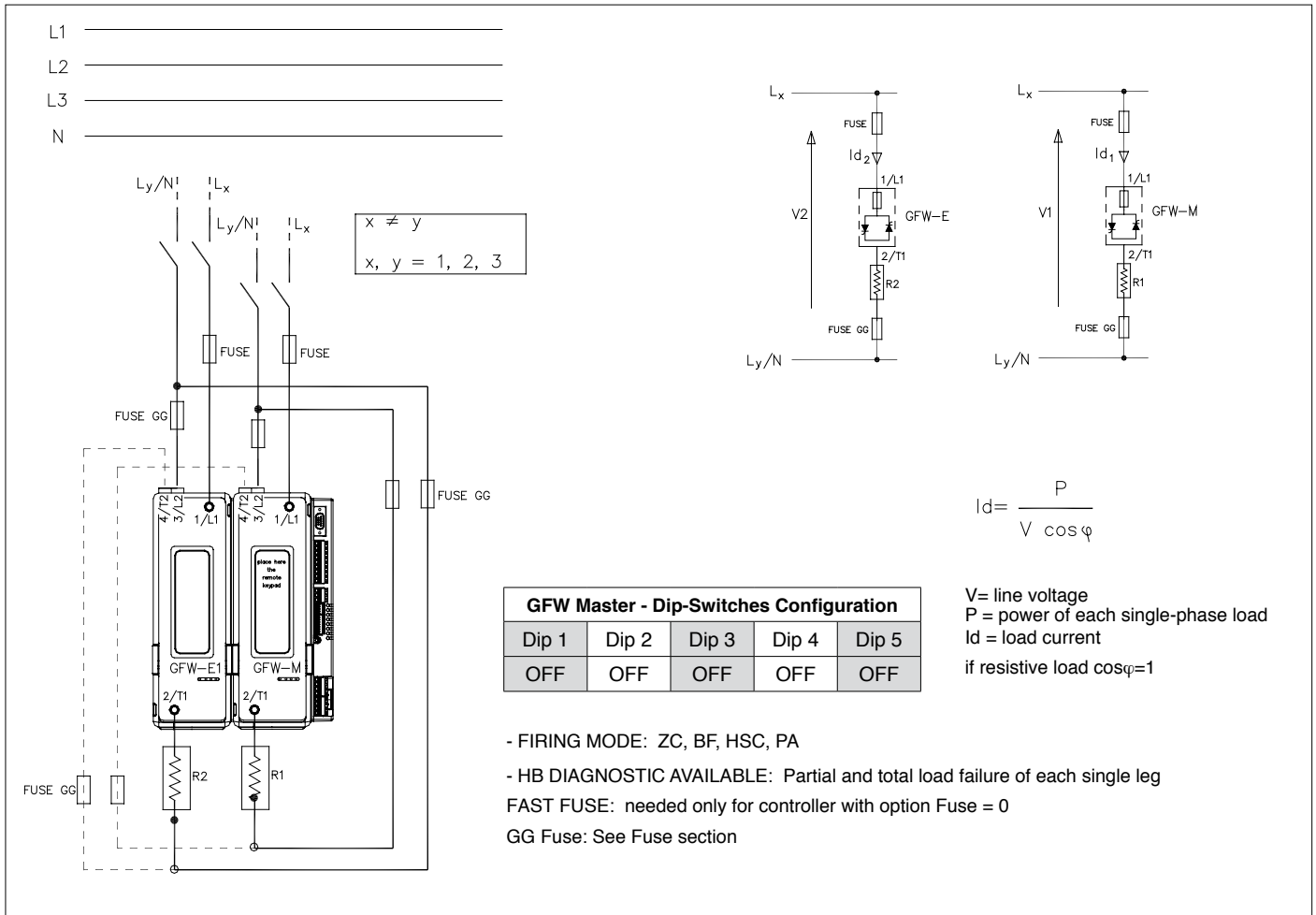


Figure 50 Example of GFW-2PH for 2 independent single phase loads

It is possible to connect two single-phase loads also to different line voltages, between line to line or line to neutral
 It is possible to manage different power values for each one of the two loads.





3.13 NOTES: USE WITH INDUCTIVE LOADS AND TRANSFORMERS

- a) when the GFW is working it is not allowed to open neither the connection between GFW and the transformer nor the connection between the transformer and the load
- b) The maximum current controllable by the device is less than the product's rated value (see technical data).
- c) In ZC and BF trigger mode, use the Delay-triggering function to limit peak magnetization current.
- d) In PA trigger mode, use the Softstart function.
- e) DO NOT use HSC trigger mode.
- f) DO NOT connect RC snubbers in parallel to the transformer primary.
- g) Always set Dip-Switch 5 to ON (and run the initial configuration procedure described in paragraph 3.7)

3.14 TRIGGER MODES

The GFW has the following power control modes:

- modulation via variation of number of conduction cycles with zero crossing trigger.
- modulation via variation of phase angle.

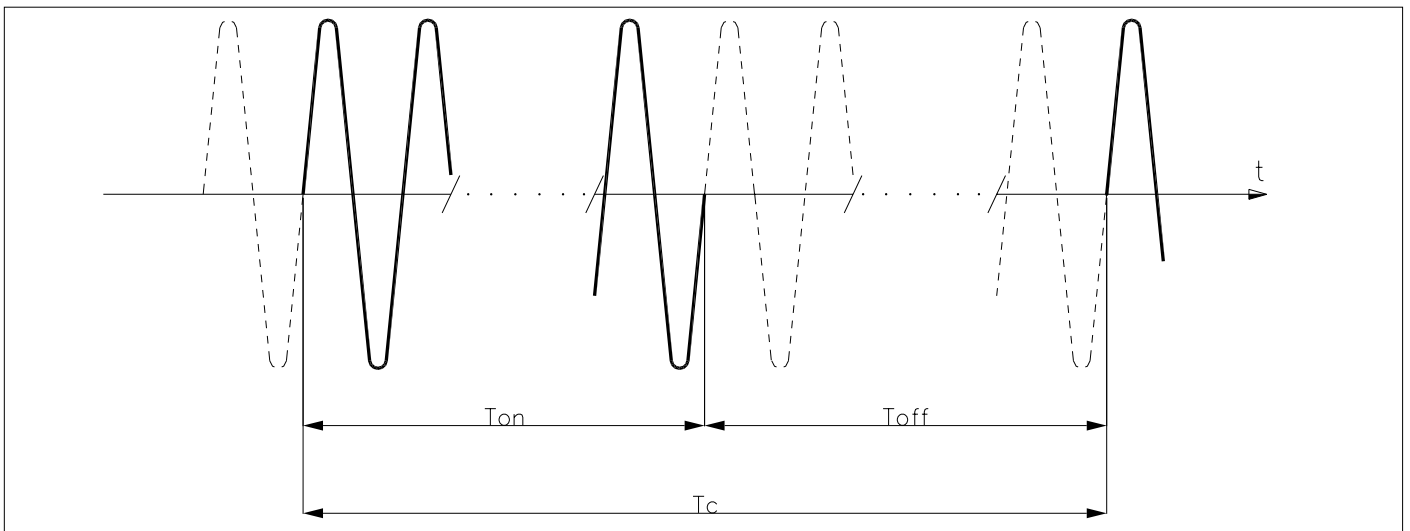
Zero Crossing mode

This function eliminates EMC noise. This mode controls power on the load via a series of conduction ON and non conduction OFF cycles.

ZC - constant cycle time ($T_c \geq 1$ sec, settable from 1 to 200 sec)

Cycle time is divided into a series of conduction and non conduction cycles in proportion to the power value to be transferred to the load.

Figure 51



For example, if $T_c = 10$ sec, if the power value is 20% there is conduction for 2 sec (100 conduction cycles @ 50Hz) and non conduction for 8 sec (400 non conduction cycles @ 50Hz).

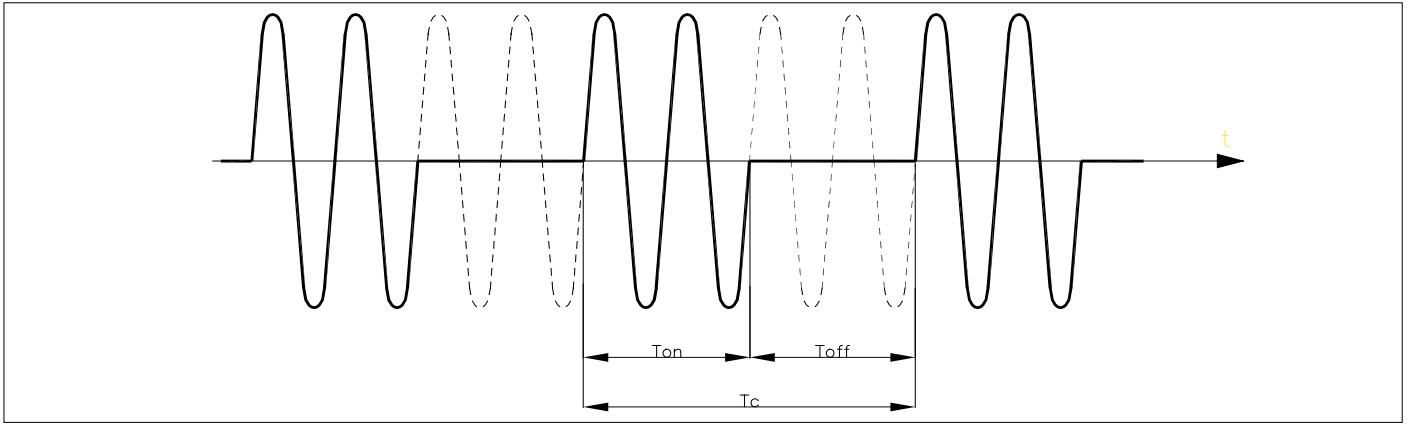
BF - variable cycle time (GTT)

This mode controls power on the load via a series of conduction ON and non conduction OFF cycles.

The ratio of the number of ON cycles to OFF cycles is proportional to the power value to be supplied to the load.

The CT repeat period is kept to a minimum for each power value (whereas in ZC mode the period is always fixed and not optimized).

Figure 52



parameter defines the minimum number of conduction cycles settable from 1 to 10.
In the following example, the parameter = 2.

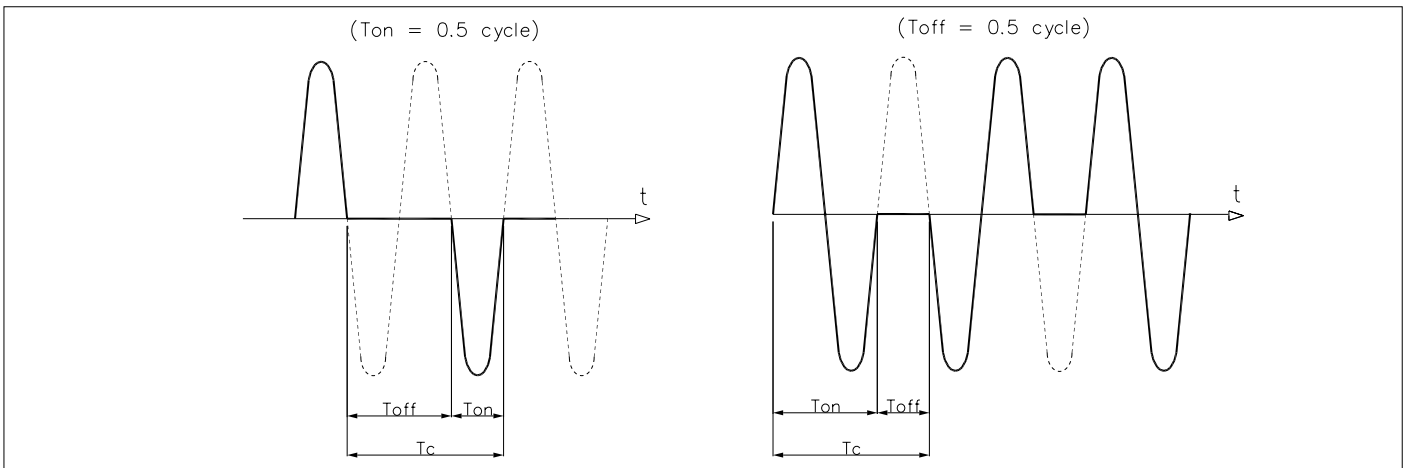
HSC - Half single cycle



This mode corresponds to Burst Firing that manages ON and OFF half-cycles. It is useful for reducing the flickering of filaments with short/medium-wave IR lamp loads. With these loads, to limit operating current with low power, it is useful to set a minimum power limit (for example $Lo.P = 10\%$, ref "GFX4-IR operation guide").

NB.: This mode is NOT allowed with inductive loads (transformers) It is used with resistive loads in single-phase, star with neutral, or open delta configuration.

Figure 53



Example of operation in HSC mode with power at 33 and 66%.

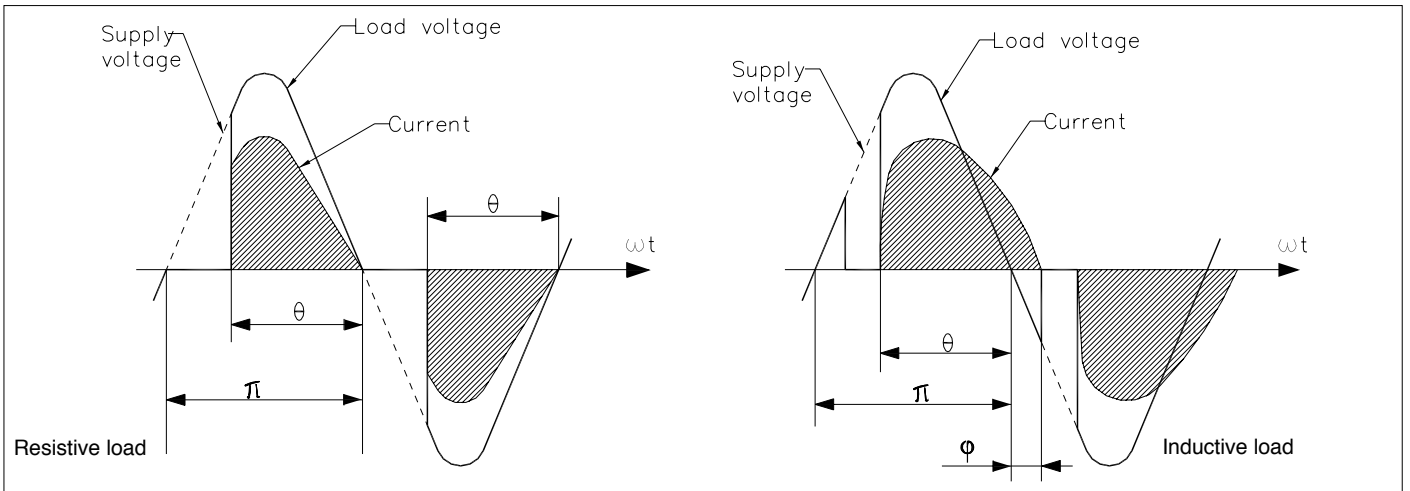
Phase angle (PA)

This mode controls power on the load via modulation of trigger angle θ

if power to be transferred to the load is 100%, $\theta = 180^\circ$

if power to be transferred to the load is 50%, $\theta = 90^\circ$

Figure 54



ADDITIONAL FUNCTIONS

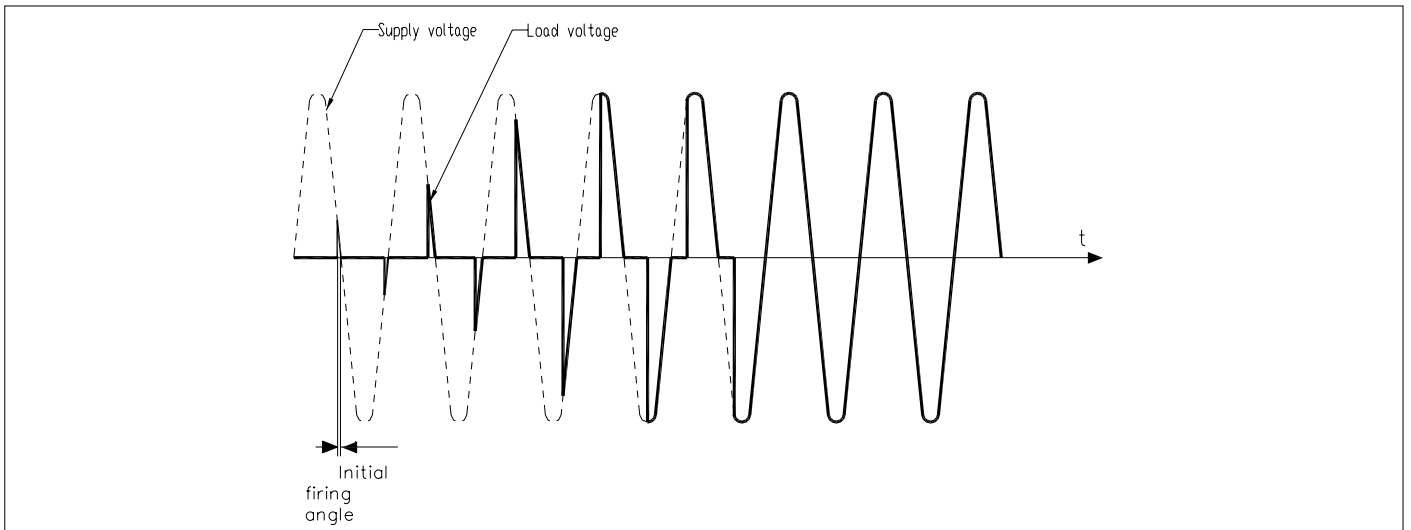
Softstart

This type of start can be enabled either in phase control or pulse train mode and in zero-crossing mode (ZC, BF, HSC).

In phase control, the increment of conduction angle α stops at the corresponding value of the power to be transferred to the load.

Control of maximum peak current (useful in case of short circuit on the load or of loads with high temperature coefficients to automatically adjust start time to the load) can be enabled during softstart. When the load shut-off time (settable) is exceeded, the ramp is reactivated at the next power-on.

Figure 55



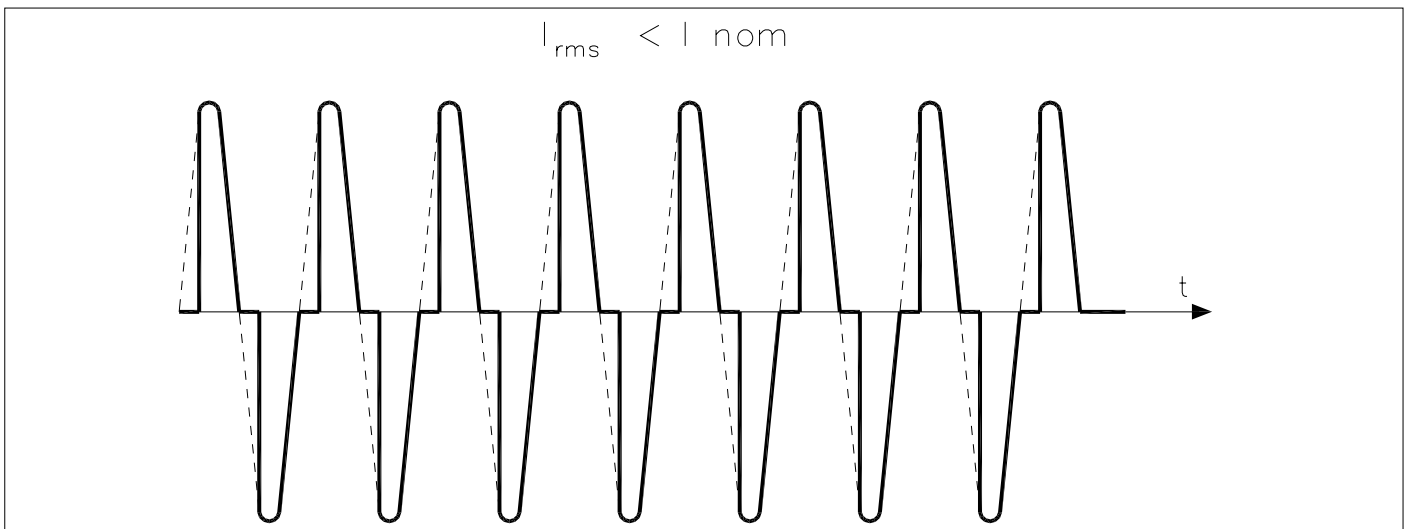
Example of firing ramp with phase Soft-Start

RMS current limit

The option for controlling the load current limit is available in all work modes.

If the current value exceeds the limit (settable in the nominal full-scale range) in mode PA the conduction angle is limited, while in zero-crossing mode (ZC, BF, HSC) the cycle time conduction percentage is limited. This limitation ensures that the RMS value (i.e., not the instantaneous value) of the load current does NOT exceed the set RMS current limit.

Figure 56



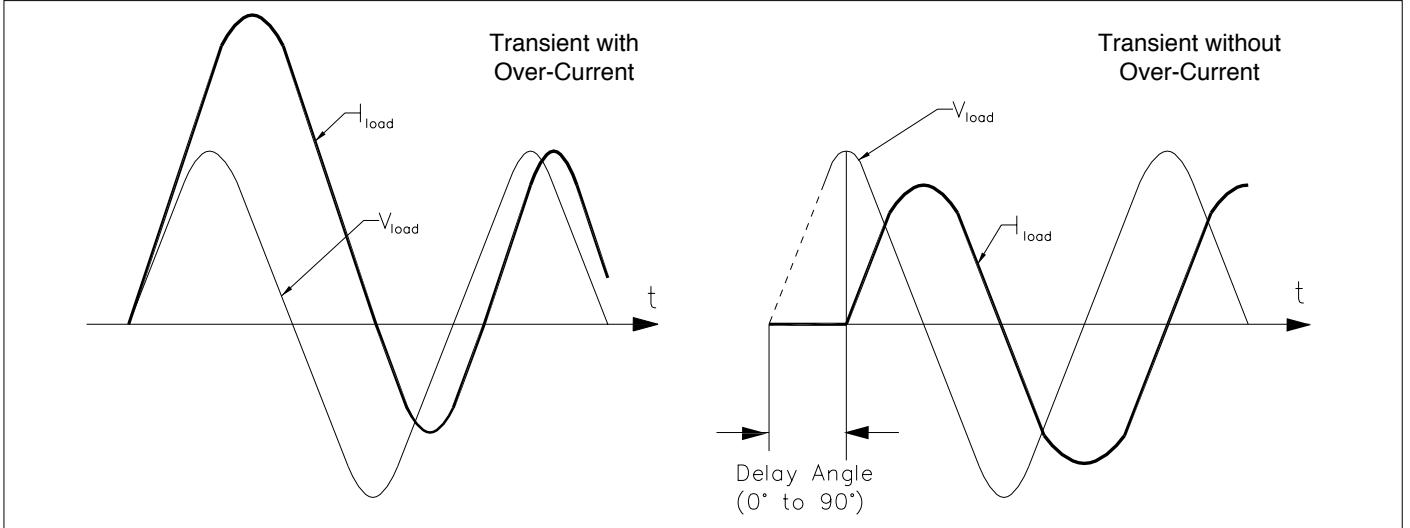
Example of conduction angle limitation in PA mode to respect an RMS current limit below the nominal current of the load.

DT - "Delay triggering" (for ZC, BF control modes only)

Settable from 0° to 90°.

Useful for inductive loads (transformer primaries) to prevent current peak that in certain cases could trip the high-speed fuses that protect the SCRs.

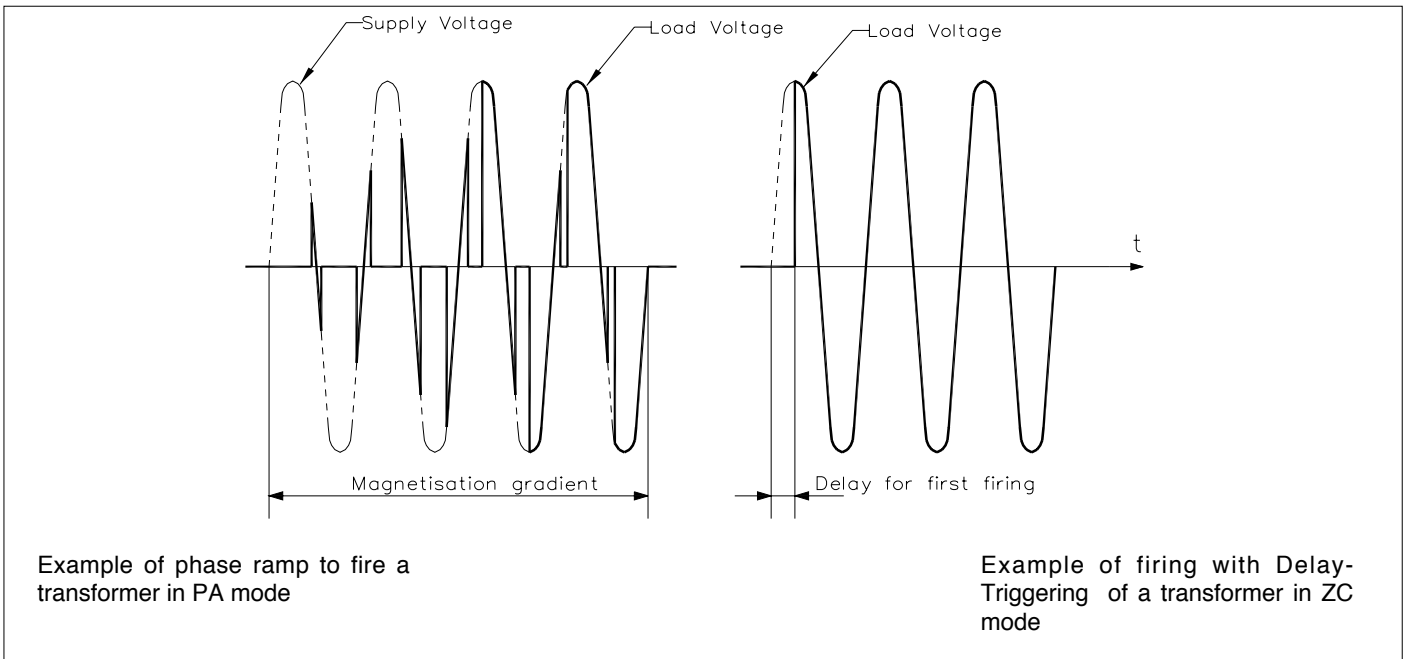
Figure 57



Example of firing of inductive load with/without delay-triggering.

To conduct inductive loads controlled in PA mode, do not use delay triggering; instead, use the phase Soft-Start ramp.

Figure 58



Example of phase ramp to fire a transformer in PA mode

Example of firing with Delay-Triggering of a transformer in ZC mode

Comparison of method to fire a transformer: Soft-Start Ramp (for PA mode) / Delay triggering (for ZC and BF mode)

3.15 DIGITAL INPUT (PWM)

This digital input can be used to receive information on the % of power to be supplied to the load.

The signal can be generated by a controller or external plc via digital outputs (logic output for Gefran instrumentation).

This is obtained by alternating the output in ON for time TON with the output in OFF for time TOFF.
The sum of TON+TOFF is constant, and is called CycleTime.

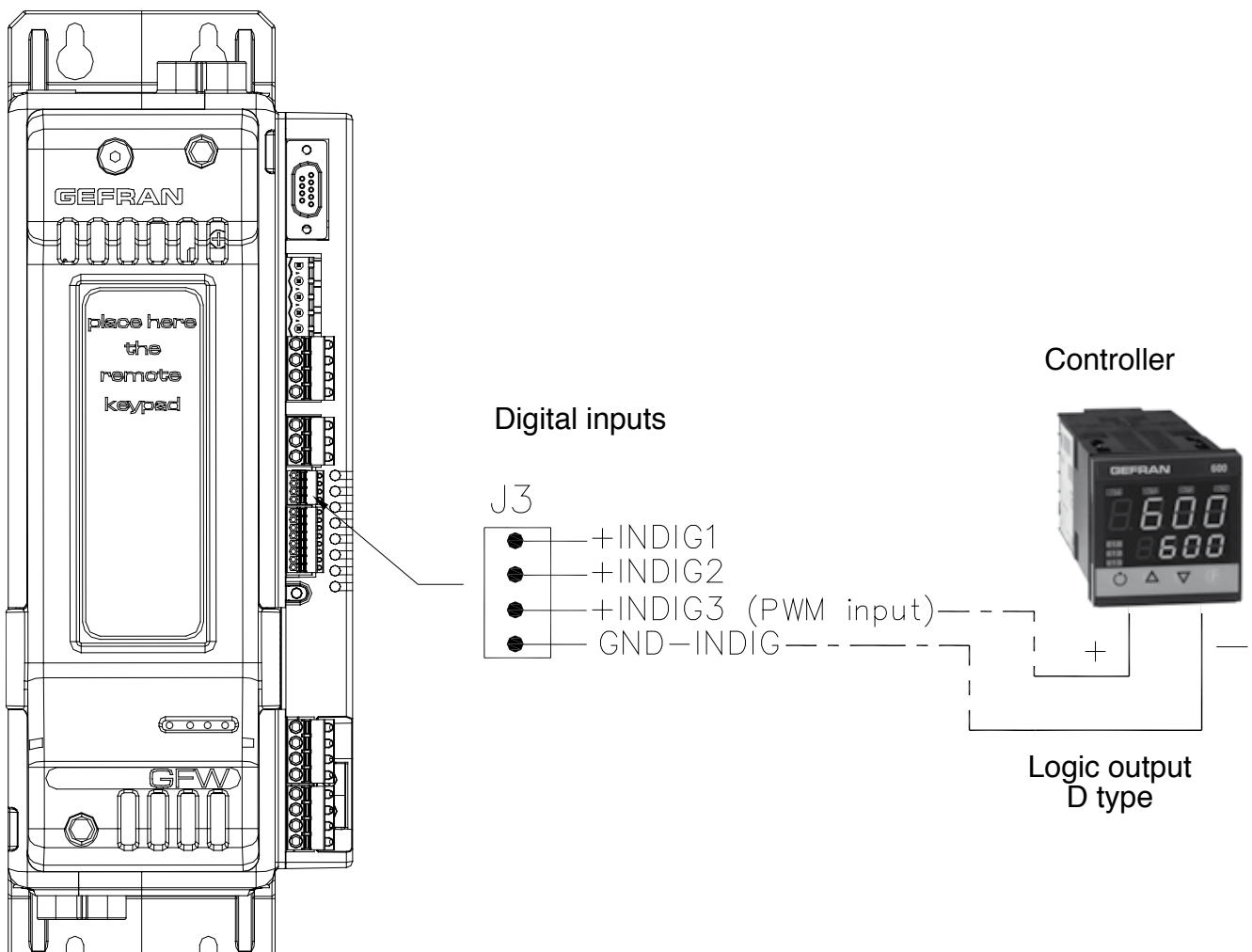
$$\text{CycleTime} = \text{TON} + \text{TOFF}$$

The power level is given by the ratio = $\text{TON} / \text{CycleTime}$ and is normally expressed in %.

The GFW digital input automatically adapts to the cycle time from 0.03Hz to 100Hz and obtains the power % to be supplied to the load from the $\text{TON} / (\text{TON} + \text{TOFF})$ ratio.

Connection example:

Temperature control with Gefran 600 with D type logic output (out2) (cycle time: 0.1sec), GFW without PID option, logic output can drive max 3 GFW in series (preferable), connection allowed only if GFWs do not have interconnected GNDs (if so, make parallel connection).



4 • INSTALLATION OF “MODBUS” SERIAL NETWORK

A network typically has a Master that “manages” communication by means of “commands,” and Slaves that carry out these commands.

GFW modules is considered Slaves to the network master, which is usually a supervision terminal or a PLC.

It is positively identified by means of a node address (ID) set on rotary switches (tens + units).

A maximum of 99 GFW, modules can be installed in a serial network, with node address selectable from “01” to “99”.

GFW modules has a ModBus serial (Serial 1) and, optionally (see order code) a Fieldbus serial (Serial 2) with one of the following protocols: Modbus RTU, Profibus DP, CANopen, DeviceNet e Ethernet Modbus TCP.

The MODBUS RTU port 1 has the following factory settings (default):

Parameter	Default	Range
ID	1	1...99
BaudRate	19,2Kbit/s	1200...115kbit/s
Parity	None	parity/odd parity/none
StopBits	1	-
DataBits	8	-

The following procedures are indispensable for the Modbus protocol. For the other protocols, see the specific Geflex manuals.

The use of rotary switches (A...F) letters is for particular procedures described in the following paragraphs.

Here are the tables showing them:

Procedure	Positions of rotary switches		Description
	Tens	Units	
AutoBaud	0	0	It enables to set the correct BaudRate value automatically detecting the master transmission frequency

Function

Adapt the serial communication speed and parity of the GFW modules to the connected supervision terminal or PLC.



Green LED L1 “STATUS” mentioned in the procedure can vary its behavior based on parameter Ld.1, which is set to a default value of 16.

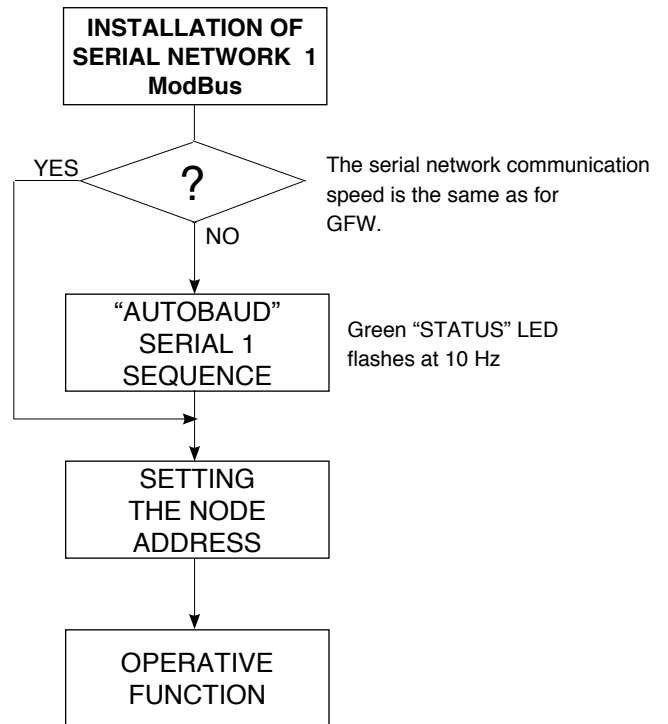
Procedure

- 1) Connect the serial cables for all modules on the network to serial 1 and to the supervision terminal.
- 2) Set the rotary switch on the GFW modules to be installed, or on all modules present in case of first installation, to position “0+0”.
- 3) Check that the green “STATUS” LEDs flash at high frequency (10Hz).
- 4) The supervision terminal must transmit a series of generic “MODBUS” read messages to the network.
- 5) The procedure is over when all of the green L1 “STATUS” LEDs on the GFW modules flash at a normal frequency (2Hz) (if parameter 197 Ld.1 = 16 as default).

The new speed parameter is saved permanently in each GFW; therefore, the “AUTOBAUD SERIAL 1” sequence does not have to be run at subsequent power-ups.



When the rotary switch is turned, the green “STATUS” LED stays on steadily for about 6 seconds, after which it resumes normal operation and saves the address.



5 • TECHNICAL CHARACTERISTICS

INPUTS

INA Analogic control inputs	
Function	Acquisition of % value for power control
Voltage	Linear: 0,...,5Vdc, Ri>100Kohm Linear: 0,...,10Vdc, Ri>100Kohm
Current	Linear: 0/4...20mA, Ri =125ohm
Potentiometric	1, ..., 10Kohm, max 10mA from 5Vdc power GFW
IN1 Analog process inputs (option)	
Function	Acquisition of process variable
Max. error	0,2% f.s. ± 1 scale point at @ 25°C
Thermal drift	< 100 ppm/°C of f.s.
Sampling time	60 ms
Thermocouple Tc (ITS90)	J,K,R,S,T (IEC 584-1,CEI EN 60584-1, 60584-2) Error cold junction comp. 0,1°/°C
Resistance thermometer RTD (ITS90)	Pt100 (DIN 43760) Max line resistance 20ohm
Voltage	Linear: 0,...,60mV, Ri>1Mohm 0,...,1V, Ri>1Mohm a 32-segment custom linearization can be inserted
Current	Linear: 0/4...20mA, Ri =50ohm a 32-segment custom linearization can be inserted
IN2,...,IN5 auxiliary analog inputs (option)	
Function	Acquisition of variables (mV or Thermocouple)
Accuracy	1% f.s. ± 1 scale point @ 25°C
Sampling time	480 ms
Thermocouple Tc (ITS90)	J,K,R,S,T (IEC 584-1,CEI EN 60584-1, 60584-2) Error cold junction comp 0,1°/°C
Voltage	Linear: 0,...,60mV, Ri>1Mohm
Line Voltage measurement, Current /Voltage (optional) on load	
RMS line voltage measurement function	Line voltage read 50-60Hz; voltage in range : 90...530Vac for model with work voltage range 480Vac 90...660Vac for model with work voltage range 600Vac 90...760Vac for model with work voltage range 690Vac
Accuracy RMS line voltage measurement	1% f.s. with neutral connected, 2% f.s. without neutral
RMS current measurement function	Load current read
Accuracy RMS current measurement	2% f.s. @25°C in start mode ZC e BF; in mode PA 2% f.s. with conduction angle >90°, 4% f.s. with conduction angle <90°
Function voltage measurement RMS on load	Load voltage read
Accuracy RMS voltage measurement on load	1% f.s. with VLOAD option measurement (Otherwise, the value is calculated from the values of line voltage and power delivered; accuracy 2% F.S.)
Thermal drift for measure tension and current in the load, tension of line	<0,02%/°C
Current and Voltage sampling time	0,25 ms
INDIG1,...,INDIG3 Digital inputs	
Function	Configurable (default: disabled) Only for INDIG3: PWM input (100Hz/0,03Hz) to check the % value of power which depends on the cycle; this function lets you to set a power set point by means of a digital signal (ex. from PLC or controller with PWM output).
Type	5-30Vdc, 7mA isolation 1500V
OUTPUTS	
OUT1, ..., OUT3 heat control connected directly to solid-state units	
Function	Configurable (default: heat control) State of control is displayed by LED (O1, ,O3) OUT1 is connected to Master unit, OUT2 and OUT3 are connected to Expansion units

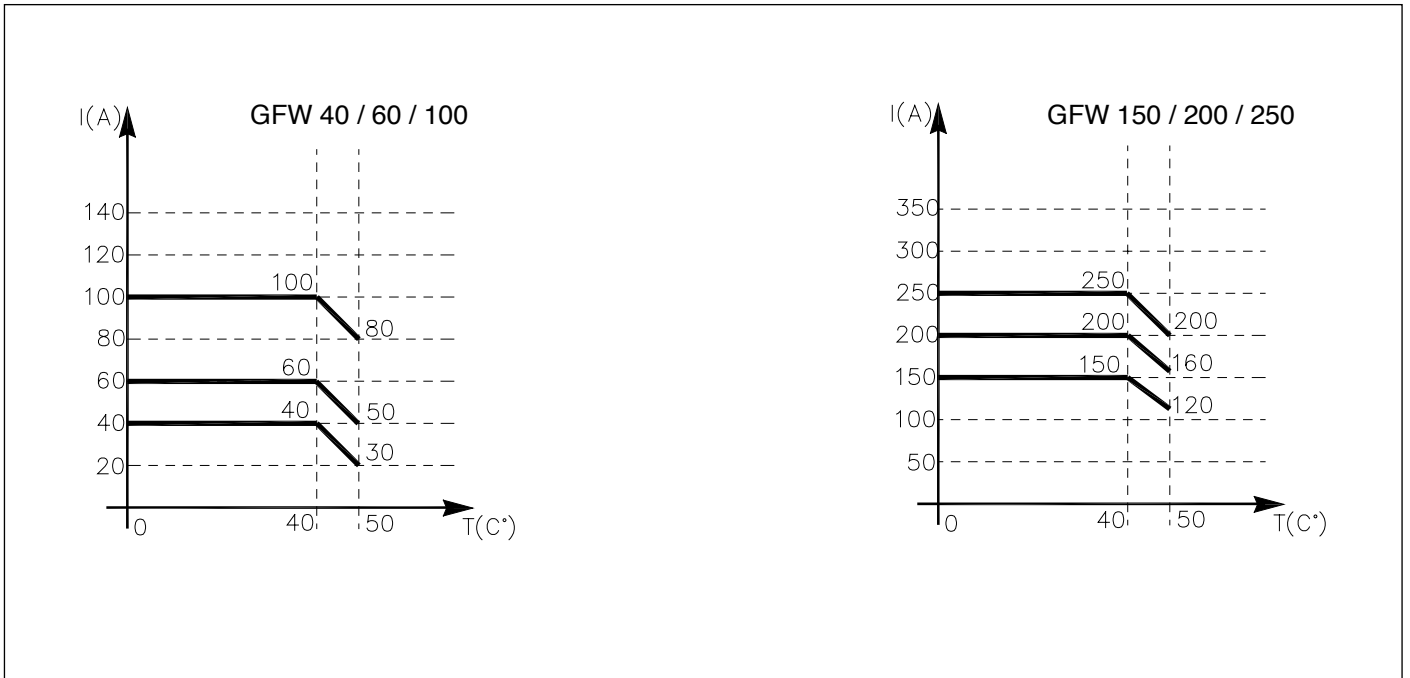
OUT5,...,OUT8 cooling control outputs (option)	
Function	Configurable (default: cooling control)
Relay	Contact NO 3A, 250V/30Vdc $\cos\phi = 1$
Continuous	0/2...10V (default), max 25mA short circuit protection 0/4...20mA, max. load 500ohm isolation 500V
Logic	24Vdc, > 18V a 20mA
Triac	230V/ max 4A AC51 (1A for each channel)
OUT9, OUT10 alarm	
Function	Function Configurable (default alarms)
Relay	Contact NO 5A, 250V/30Vdc $\cos\phi = 1$
COMMUNICATIONS PORTS	
PORT GFW-OP	
Function	Serial communication for KB-ADL terminal to display parameter programming
PORT1 (always present)	
Function	Function Local serial communication
Protocol	ModBus RTU
Baudrate	Settable 1200,...,115200, (default 19,2Kbit/s)
Node address	Node address Settable with rotary-switches
Type	RS485 - isolation 1500V, double connector RJ10 telephone type 4-4
PORT2 (Fieldbus option)	
Function	Fieldbus serial communication
Protocol	ModBus RTU, type RS485, baudrate 1200...115000Kbit/s CANOpen 10K...1Mbit/s DeviceNet 125K...0,5Mbit/s Profibus DP 9,6K...12 Mbit/s Ethernet Modbus TCP 10/100Mbit/s Ethernet IP 10/100Mbit/s EtherCAT 100Mbps
POWER (Solid-state relay)	
CATEGORY OF USE (Tab. 2 EN60947-4-3)	AC 51 resistive or low inductance loads AC 55b short wave infrared lamps (SWIR) AC 56a transformers, resistive loads with high temperature coefficient
Trigger mode	PA - load control via adjustment of firing phase angle ZC - Zero Crossing with constant cycle time (settable in range 1-200sec) BF - Burst Firing with variable cycle time (GTT) optimized min. HSC - Half Single Cycle corresponds to Burst Firing that includes ON and OFF half-cycles. Useful for reducing flicker with short-wave IR loads (applied only to calibrate each time you change feedback mode.
Feedback mode	V, V2 Voltage feedback: proportional to RMS voltage value on load to compensate possible variations in line voltage. I, I2 Current feedback: proportional to RMS current value on load to compensate variations in line voltage and/or variations in load impedance. W Power feedback: proportional to real power value on load to compensate variations in line voltage and/or variations in load impedance. You have to calibrate each time you change feedback mode.
Max rated voltage	480Vac to 600Vac or 690V
Work voltage range	90...530Vac (models 480V) 90...660Vac (models 600V) 90...760Vac (models 690V)
Non-repetitive voltage	1200Vp (models 480V) 1600Vp (models 600V / 690V)
Rated frequency	50/60Hz auto-determination
Critical Dv/dt with output deactivated	1000V/ μ sec
Held nominal voltage of on the impulse	4KV
Nominal current for short circuit condition	5KA
Protection	RC, extrarapid fuses for SCR

<p>Rated current AC51 non-inductive or slightly inductive loads, resistance furnaces</p>	<p>GFW 40 Nominal current 40Arms @40°C in continuous service Non-repetitive overcurrent t=10ms: 1400A I²t per fusione: 10000A²s</p> <p>GFW 60 Nominal current 60Arms @40°C in continuous service Non-repetitive overcurrent t=10ms: 1500A I²t for blowout: 12000A²s</p> <p>GFW 100 Nominal current 100Arms @40°C in continuous service Non-repetitive overcurrent t=10ms: 1900A I²t for blowout: 18000A²s</p> <p>GFW 150 Nominal current 150Arms @40°C in continuous service Non-repetitive overcurrent t=10ms: 5000A I²t for blowout: 125000A²s</p> <p>GFW 200 Nominal current 200Arms @40°C in continuous service Non-repetitive overcurrent t=10ms: 8000A I²t per fusione: 320000A²s</p> <p>GFW 250 Nominal current 250Arms @40°C in continuous service Non-repetitive overcurrent t=10ms: 8000A I²t for blowout: 320000A²s</p> <p>NOTA (all models) Minimum load controllable: 5 % of product current rated level.</p>
<p>Thermic Dissipation</p>	<p>GFW models dissipate thermic power based on load current: Pdissipation = I_load_Arms * 1.3V (W) For models with integrated fuse, also consider dissipated power at rated current shown on the fuse table GFW models with electronic fuse (with internal IGBT) dissipate thermic power based on load current: Pdissipation = I_load_Arms * 2.8V (W)</p>
<p>Rated current AC56A permitted trigger modes: ZC, BF con DT (Delay Triggering), PA with softstart</p>	<p>Derating: 20% of rated current value.</p>
FUNCTION	
<p>Safety</p>	<p>Detection of short circuit or opening of inputs, absence of input feed, LBA alarm, HB alarm</p>
<p>Selection of °C/°F</p>	<p>Configurable</p>
<p>Linear scale range</p>	<p>-1999...9999</p>
<p>Control actions</p>	<p>1 control loops: Double action (heat/cool) PID, on-off Self-tuning at start, continuous Autotuning, one-shot Autotuning</p>
<p>PID parameters: pb-dt-it</p>	<p>0,0...999,9 % – 0,00...99,99 min – 0,00...99,99 min</p>
<p>Action – control outputs</p>	<p>heat/cool – ON/OFF, PWM, GTT</p>
<p>Max limit heat/cool power</p>	<p>0,0...100,0 %</p>
<p>Fault power setting</p>	<p>-100,0...100,0 %</p>
<p>Shutdown function</p>	<p>Maintains sampling of PV; maintains control off</p>
<p>Configurable alarms</p>	<p>The alarm is assignable to an output and configurable as: maximum, minimum, symmetrical, absolute/deviation, LBA, HB</p>
<p>Alarm masking</p>	<p>Exclusion at power-on, latch, reset from digital input</p>
<p>Energy calculation</p>	<p>Totalizer of energy value supplied to load with local display by terminal and remote acquisition from fieldbus. Counters can be reset.</p>

OPTIONS				
Options	<ul style="list-style-type: none"> - Timed Soft-Start firing ramp, with or without peak current control - Soft-Start firing ramp, specific for infrared lamps - Timed shut-off ramp - Limitation of RMS current in load - 0-90° Delay-Triggering for firing inductive loads in ZC and BF mode 			
Diagnostics	<ul style="list-style-type: none"> - SCR in short circuit (presence of current with OFF control) - No linear voltage - Fan supply power missing - No current due to open SCR/interrupted load • Overheat alarm (of power modules, of clamps for power cables, of fuse) Current reading <ul style="list-style-type: none"> • Allarme HB carico interrotto o parzialmente interrotto • Calibration procedure using automatic threshold HB alarm from the value of the load current <ul style="list-style-type: none"> • Alarm load short circuit or overload Voltage reading <ul style="list-style-type: none"> • Input phase unbalanced • Wrong phase rotation in three-phase load configuration 			
Type of connection and load Selection via dip-switches	<ul style="list-style-type: none"> - with one Master unit: 1 single-phase load - with one Master units and one Expansion: 2 single-phase loads in ZC and BF trigger mode only: 1 phase load closed delta controlled on two phases 1 phase load star without neutral controlled on two phases - with one Maste units and two Expansions: 3 single-phase loads 3 independent single-phase loads open delta 1 phase load open delta 1 phase load closed delta 1 phase load star with neutral 1 phase load star without neutral 			
GENERAL DATA				
Power supply	24Vdc ±10%, Clas II, max 8VA Max 10VA with GFW-OP terminal - isolation 1000V			
Fan power supply	24Vdc ±10%, 500mA @ 25Vdc			
Signals	<p>Eight led:</p> <ul style="list-style-type: none"> RN (Green) run state of CPU ER (Red) error signal DI1, DI2, (Yellow) state of digital inputs INDIG1, INDIG2 O1,O2,O3 (Yellow) state of power control BT (Yellow) state key HB 			
Protection	IP20			
Work/storage temperature	0 50°C (refer to dissipation curves) / -20 85°C			
Relative humidity	20...85% RH non-condensing			
Ambient conditions for use	indoor use, altitude up to 2000m			
Installation	panel with screws			
Installation requirements	Installation category II, pollution level 2, double isolation Max. temperature of air surrounding device 40°C for temperature >40°C refer at derating curves - Device type: "UL Open Type"			
Weight	Model with internal fuse	Master	Master +1 Expansion	Master + 2 Expansions
	40A	2,2 kg	4,2 kg	6,2 kg
	60A	2,2 kg	4,2 kg	6,2 kg
	100A	2,2 kg	4,2 kg	6,2 kg
	150A	2,3 kg	4,4 kg	6,5 kg
	200A	2,6 kg	5,0 kg	7,4 kg
	250A	2,6 kg	5,0 kg	7,4 kg
Packaging dimension	master/expansion		model 2PH or 3PH	
	310x170x225 mm		410x355x260 mm	

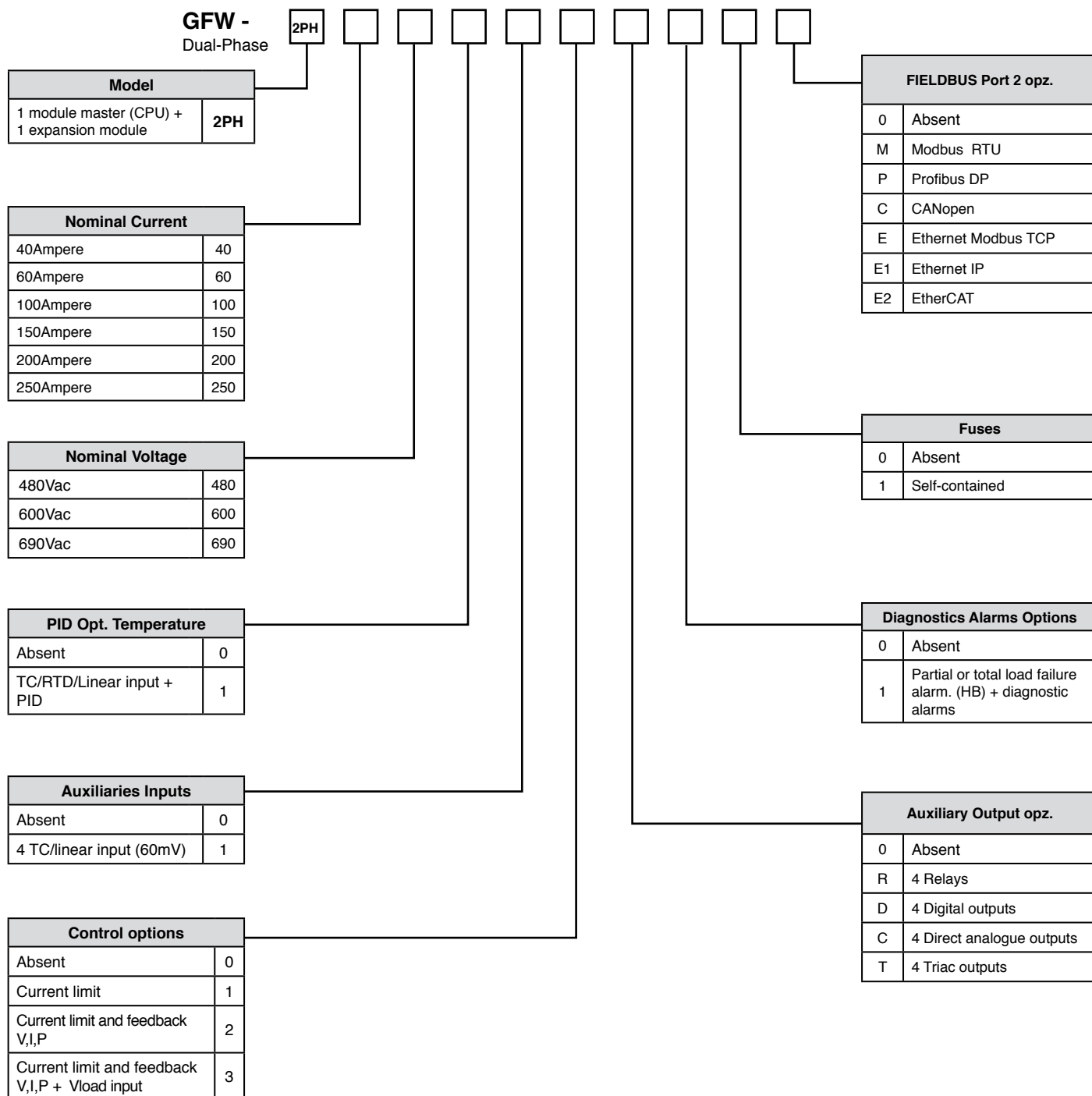
5.1 DERATING CURVES

Figure 59



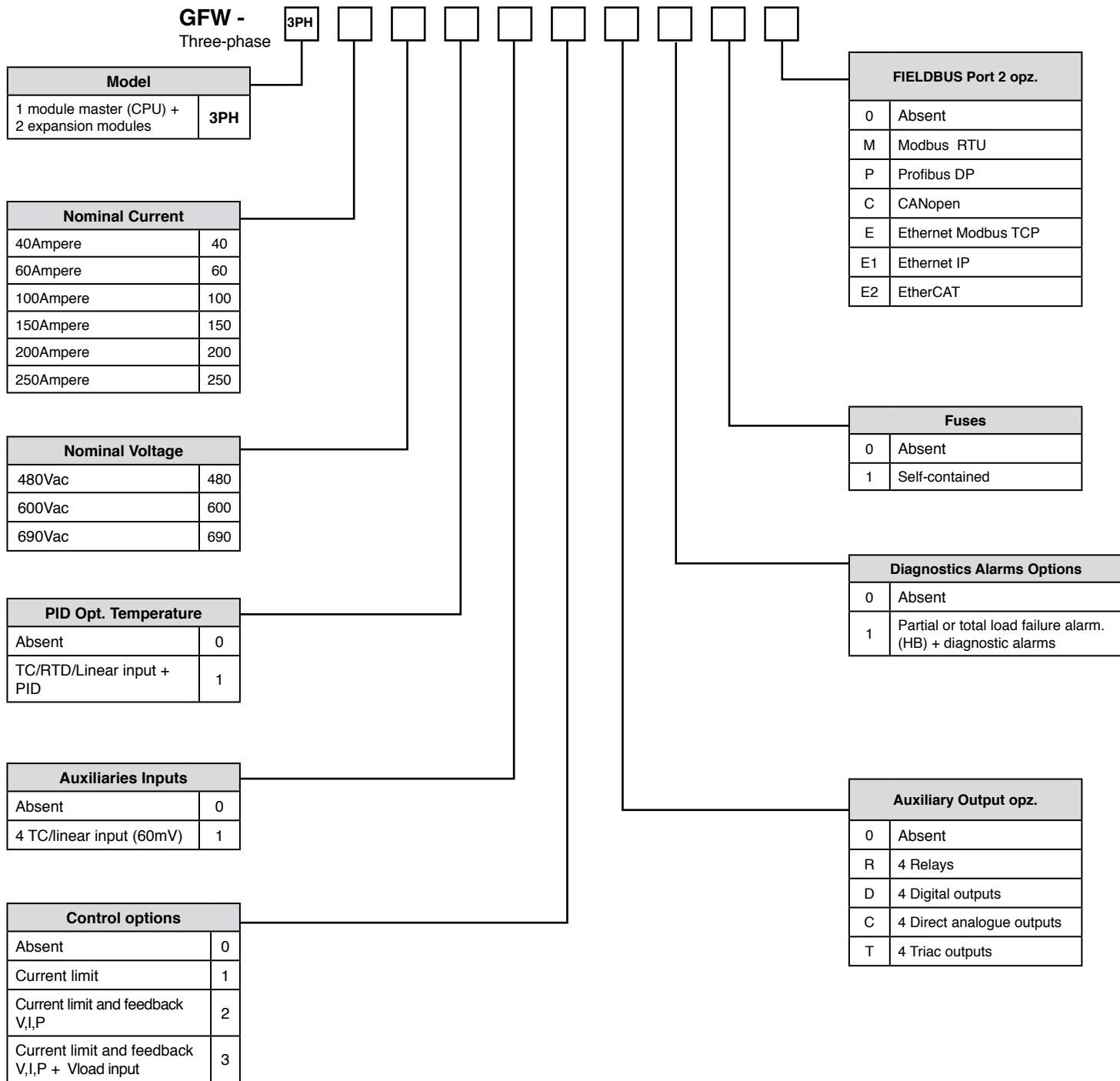
6 · Commercial Information

6.1 ORDER CODE



6 · Commercial Information

6.1 ORDER CODE



6.2 ACCESSORIES

CONFIGURATION KIT



Configuration/supervision kit for GFW by means of PC with USB (Windows environment).

Lets you read or write all of the parameters of a single GFW

A single software for all models

- Easy and rapid configuration
- Saving and management of parameter recipes
- On-line trend and saving of historical data

Component Kit:

- Connection cable PC USB <----> GFW RS485 port
- Serial line converter
- CD SW GF Express installation

ORDERING CODE

GF_eXK-2-0-0.....Cod. F049095



The human/machine interface (HMI) is simple, intuitive, and very practical thanks to the optional GFW – OP programming keyboard.

Lets you read or write all of the parameters of a single GFW-M module.

Connected with 9-pin D-SUB connector and housed in the front panel of the GFW-M by means of a magnetic plate.

- Alphameric display: 5 lines x 21 characters.
- Keys to display variable and set parameters.
- Magnetic housing

ORDERING CODE

GFW - OP.....Cod. F051664

6.2 FUSES EXTRARAPID

Model	EXTRARAPID FUSES			
	Size I ² t	Code Format	Model Code	Power Dissipated @ In
GFW 40	80A 2500A ² s	FUS-080S	DN000UB69V80 338933	5 W
GFW 60	125A 8900A ² s	FUS-125S	DN000UB69V125 338934	6 W
GFW 100	160A 16000A ² s	FUS-160S	DN000UB69V160 338935	12 W
GFW 150	200A 31500A ² s	FUS-200S	DN000UB69V200 338930	19 W
GFW 200/250 480/600V	450A 196000A ² s	FUS-450S	DN00UB60V450L 338932	17 W
GFW 200/250 690V	400A 150000A ² s	FUS-400S	DN00UB69V400L 338936	20 W

6.3.1 Fuse GG

The electric protection device called FUSE GG must be done in order to grant the protection against the electric cable short circuit (see EN60439-1, par. 7.5 “Short-circuit protection and short-circuit with stand strength” and 7.6 “Switching devices and components installed in assemblies”, otherwise the equivalent EN61439-1 paragraphs)