



INSTALLATION AND INSTRUCTION MANUAL



code: 80995D_11-2015_ENG

ATTENTION!

This manual must always be available to operators of the devices described here.

Always make sure that you have the latest version of the manual, which is available for free download from the GEFGRAN website (www.gefran.com).

Installers and/or maintenance personnel are required to read this manual and to precisely follow the instructions contained in it and in its attachments.

GEFRAN will not be liable for any damage to persons and/or property, or to the product itself, caused by failure to follow the instructions and observe the warnings given below.



This manual and its attachments may be freely reproduced as long as they are not changed in any way and every copy contains this warning and the declaration of ownership by Gefran S.p.A.

REVISION DOCUMENTS

DATE	CODE	UPDATE
03 / 2015	80995B_03-2015_ENG	First emission
07 / 2015	80995C_07-2015_ENG	update: I/O e431
11 / 2015	80995D_11-2015_ENG	update: EtherCAT for eCPU400 module

SUMMARIES AND TABLES OF CONTENTS

REVISION DOCUMENTS	2	Order code	45
SUMMARIES AND TABLES OF CONTENTS	3	Accessories	45
PREFACE	5	FUNCTIONAL I/O MODULE serie e43x	46
Warnings and safety.....	5	Technical data	47
Printing conventions used in the manual	5	Order codes	48
Glossary	5	Accessories	48
ePCLoGic400 SYSTEM	6	ASSEMBLY AND INSTALLATION	49
Panorama of the solution and its functions	6	Assembly Operator Panel	49
Architecture	7	<i>Hole dimensions</i>	49
Main power supply	9	<i>Protection against infiltrations of</i>	49
Order codes	11	<i>water</i>	49
Example of order model number	12	<i>Vibrations</i>	49
Accessories.....	12	<i>Minimum spaces for ventilation</i>	49
Programming tool.....	12	<i>Positioning</i>	49
<i>GF_PROJECT VX</i>	12	<i>Fastening to the panel</i>	50
ePanel Operator Panel	13	eGT-I 104-43 Faceplate	51
Technical data	14	Operator Panel Connections.....	52
Dimensions and spaces required for installation.....	15	<i>Inputs, ports and signals</i>	52
Order codes	16	<i>Power</i>	53
Accessories.....	16	<i>USB</i>	53
eGT-I OPERATOR PANEL	17	<i>DVI-D Input</i>	53
Technical Data.....	18	<i>OSD Keypad</i>	53
Dimensions and spaces required for installation.....	19	<i>Auxiliary contacts (eGT-I only)</i>	54
Order codes	20	<i>Inserting labels (eGT-I only)</i>	54
Accessories.....	20	Mounting the eKM32-104 keyboard	55
eKM32-104 KEYBOARD	21	<i>Drilling dimensions</i>	55
Technical data	22	<i>Vibrations</i>	55
Dimensions and spaces required for installation.....	23	<i>Minimum space for ventilation</i>	55
Order codes	23	<i>Positioning</i>	55
RACK FOR SYSTEM ePCLoGic400	24	<i>Fastening to support</i>	56
Technical data	24	eKM32-104 faceplate	56
Dimensions and spaces required for installation.....	25	eKM32-104 connections	57
Order code	25	<i>Inputs, ports and signals</i>	57
Accessories.....	25	<i>Power supply and communication</i>	58
CPU MODULE series eCPU400 model e491xx	26	<i>Auxiliary contacts</i>	58
Technical data	27	<i>Customizing the keys</i>	58
Order code	28	Mounting the ePCLoGic400 controller	59
Accessories.....	28	<i>Positioning</i>	60
CPU MODULE series eCPU400 model e492xx	29	Mounting CPU and I/O modules	60
Technical data	30	ePCLoGic400 Connections.....	62
Order code	31	<i>Power</i>	62
Accessories.....	31	CPU module connections.....	63
CPU MODULE series eCPU400 model e493xx	32	<i>Connectors, signals and configuration elements</i>	63
Technical data	33	<i>Selector</i>	64
Order code	34	<i>DVI-D output</i>	64
Accessories.....	34	<i>USB</i>	64
e410 DIGITAL I/O MODULE series e41x	35	<i>Ethernet</i>	64
Technical data	36	<i>RS232</i>	64
Order code	38	<i>RS485</i>	65
Accessories.....	38	<i>CAN</i>	65
Me411 DIGITAL I/O MODULE series e41x	39	<i>Rotary selector</i>	68
Technical data	40	Wiring I/O module connectors.....	68
Order code	41	I/O modules connectors	68
Accessories.....	41	e410 module connections	69
e430 FUNCTIONAL I/O MODULE series e43x	42	<i>Connectors and signals</i>	69
Technical data	43	e410 connection diagrams	70
		<i>Connector pinout</i>	70
		<i>ON/OFF digital input and output</i>	70
		<i>Digital input - Unidirectional encoder with zero</i>	71
		<i>Digital input - Bidirectional encoder with or</i>	71
		<i>without zero</i>	71

<i>Digital input - Pulse counter / encoder without</i>	
<i>zero-way</i>	72
<i>Digital output - PWM</i>	72
e411 module connections.....	73
<i>Connectors and signals</i>	73
e411 connection diagrams	74
<i>Connector pinout</i>	74
<i>ON/OFF digital input and output</i>	74
e430 module connections	75
<i>Connectors and signals</i>	75
<i>Connector pinout</i>	76
e430 connection diagrams	76
<i>Analog voltage input</i>	76
<i>Analog input in current</i>	77
<i>Analog input - Thermocouple</i>	77
<i>Potentiometer analog input</i>	78
<i>Analog input in voltage</i>	78
e431 module connections	79
<i>Connectors and signals</i>	79
<i>Connector pinout</i>	80
e431 connection diagrams	80
<i>Digital outputs</i>	80
<i>Analog input - Thermocouple</i>	81
COMMISSIONING	82
Setup program	82
eGT-I - OPERATOR INSTRUCTIONS	87
Keys and signals	87
MAINTENANCE AND DIAGNOSTICS	89
Maintenance.....	89
<i>Operator Panel</i>	89
<i>ePCLogic400 controller</i>	89
<i>Disposal</i>	89
Local diagnostics.....	89
<i>ePCLogic400 controller</i>	89
Diagnostics program	89
<i>CANopen</i>	90
<i>EtherCAT</i>	92
<i>GDNet</i>	93
<i>GILOGIK II</i>	94
<i>ePCLogic400</i>	95
<i>ICT</i>	96
<i>System</i>	99

PREFACE

Warnings and safety

While all the information contained in this manual has been carefully checked, Gefran S.p.A. accepts no responsibility for the possible presence of errors or for damage to persons and/or property caused by the improper use of the manual.

Gefran S.p.A. also reserves the right to make changes to the contents and form of this manual and to the characteristics of the devices illustrated at any time and without prior warning.

The installation of the devices illustrated in the manual must be carried out by qualified technicians in compliance with the laws and standards in force and in agreement with the instructions contained in the manual.

If the GCUBE Performa is used in applications with the risk of damages to persons, machinery or materials, its use in conjunction with alarms is essential.

It is advisable to envisage the possibility of checking the intervention of the alarms during regular operation.

Before interacting with the Controller ePCLogic400 and built-in Operator Panel ePanel or eGT-I, the operator must receive full training in the procedures of operation, emergency, diagnosis and maintenance of the system.

Printing conventions used in the manual

Pay attention to the use of the following symbols.



Highlights particularly important information which influences the correct operation of the product or of safety or an instruction which must absolutely be followed.



Highlights a risk condition for the safety of the installer or the user, due to the presence of dangerous levels of voltage

Glossary

Bootloader	Program that, in the startup (boot), loads the PLC.
Checksum	Sequence of bits that is used to verify the integrity of a file.
COBID	Communication OBject IDentifier, identificativo a 11-bit identifier of a CAN frame.
MD5	Algorithm used to calculate the checksum of the file
OSD	On Screen Display.
PDO	Process Data Object.
SDO	Service Data Object.
Watchdog	Supervision system hardware or software that recovers any system malfunctions.

ePCLoGic400 SYSTEM



Applications:

- Plastic, injection machines
- Plastic, blow molding machines
- Metal

Main characteristics:

- Graphic, PLC and IOs integrated in a single compact unit
- Compact solution (L<300 mm)
- Locally expandable
- Modular cards
- Scalable
- Easily installable, DIN rail mounting

Panorama of the solution and its functions

The ePCLoGic400 is a complete process and automation control solution: a single modular system that controls sequence and work processes, and sets and displays data and connectivity.

It does this by providing a group of technological functions such as PWM, fast counters, data logger storage, temperature PIDs, and data export via FTP for rapid creation of applications.

The ePanel and eGT-I operator interfaces can be ordered separately to combine with the ePCLoGic400 Controller, which integrates a CPU module and I/O modules.

The operator interfaces are available with different size displays, in horizontal or vertical versions, with keyboard or only with touch screen.

The Controller can be completely customized to suit the user's needs in terms of CPU power and number/type of inputs and outputs, adapting perfectly to the machine or system to be controlled.

Thanks to its flexibility and ease of use, it can be used in various industries for a wide range of process and automation control applications, such as:

- packaging;
- metal (washing, etc.);
- plastic.

Architecture

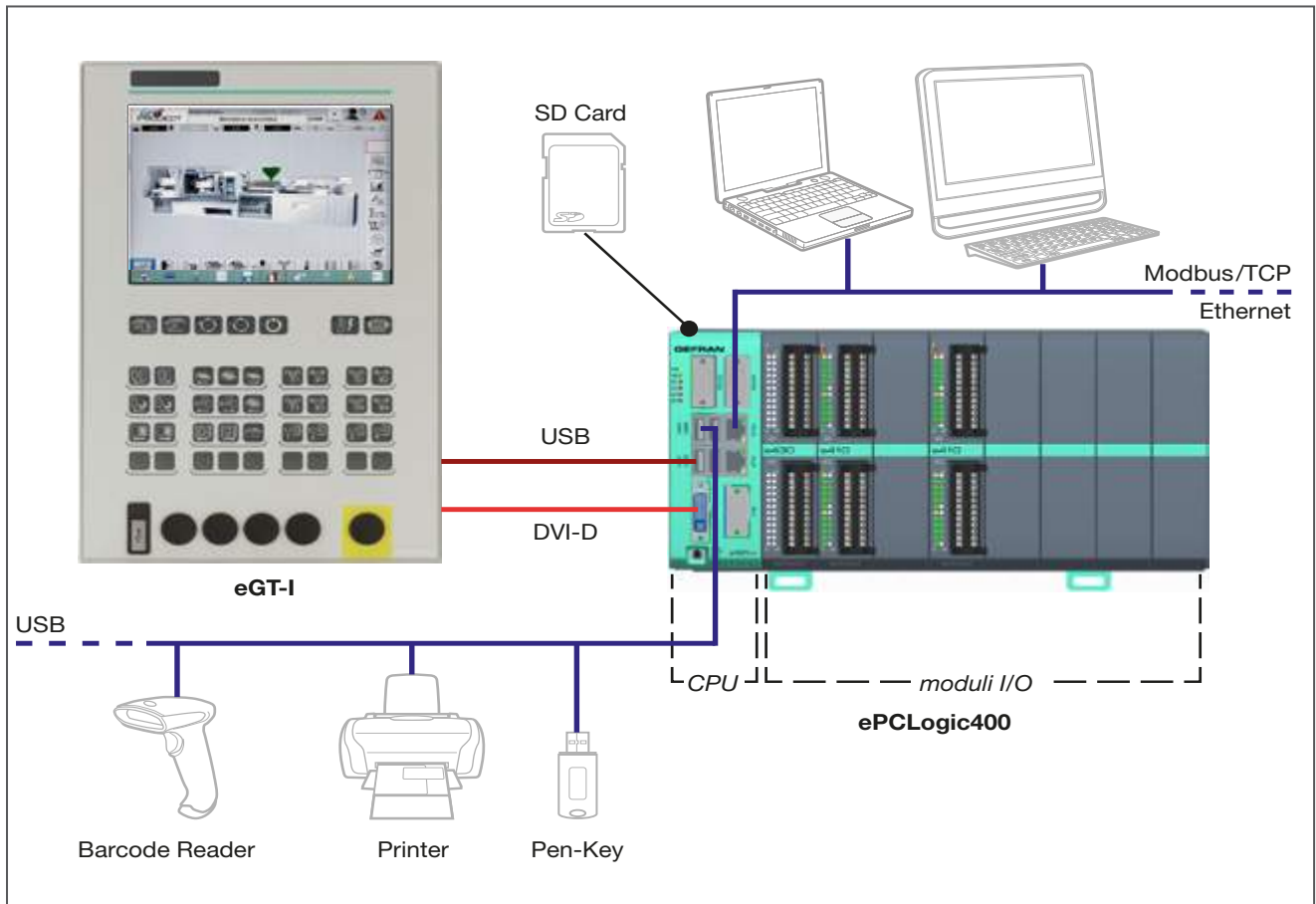

Figure 1 - System architecture

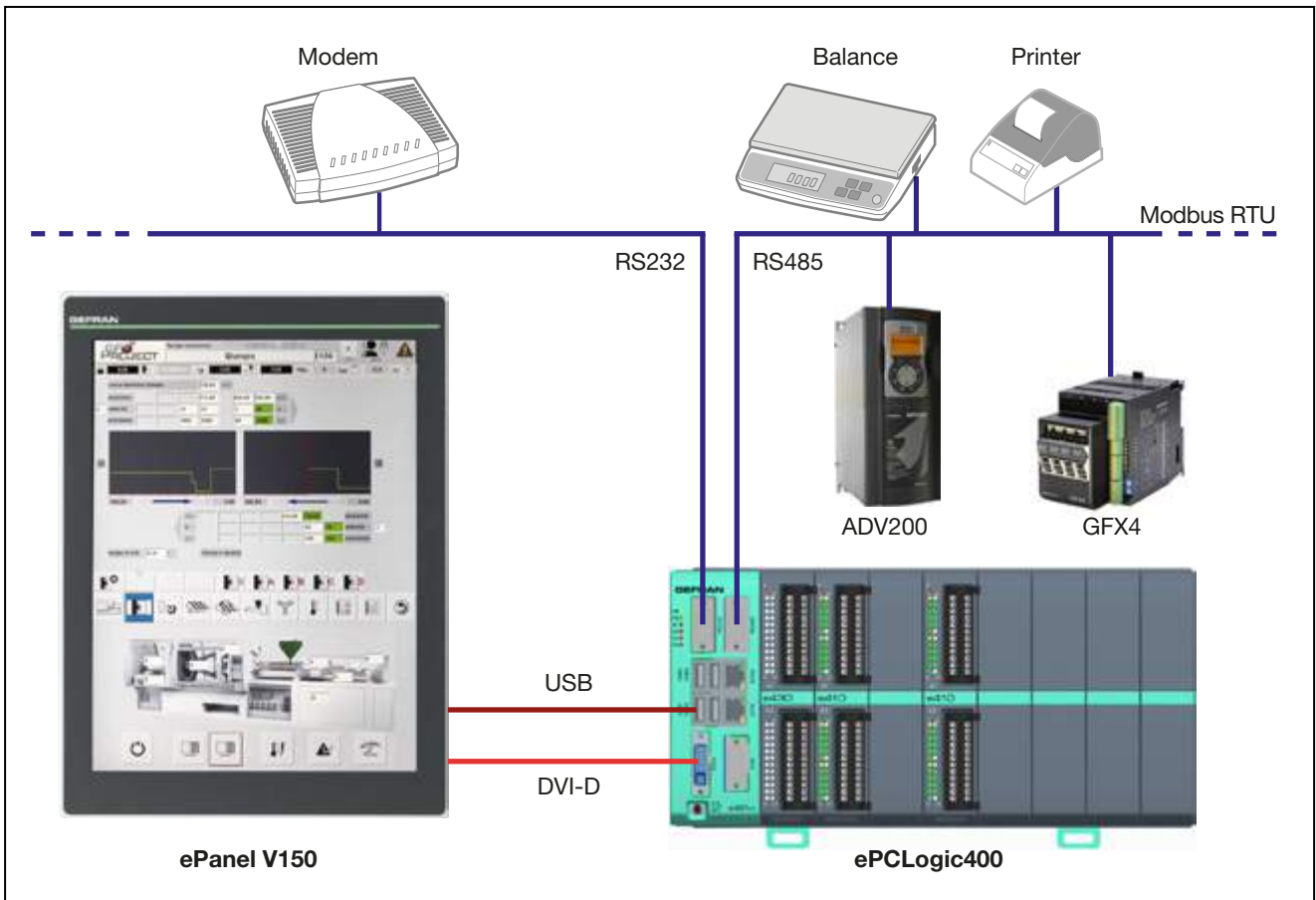

Figure 2 - RS485 / RS232 - Modbus RTU System architecture

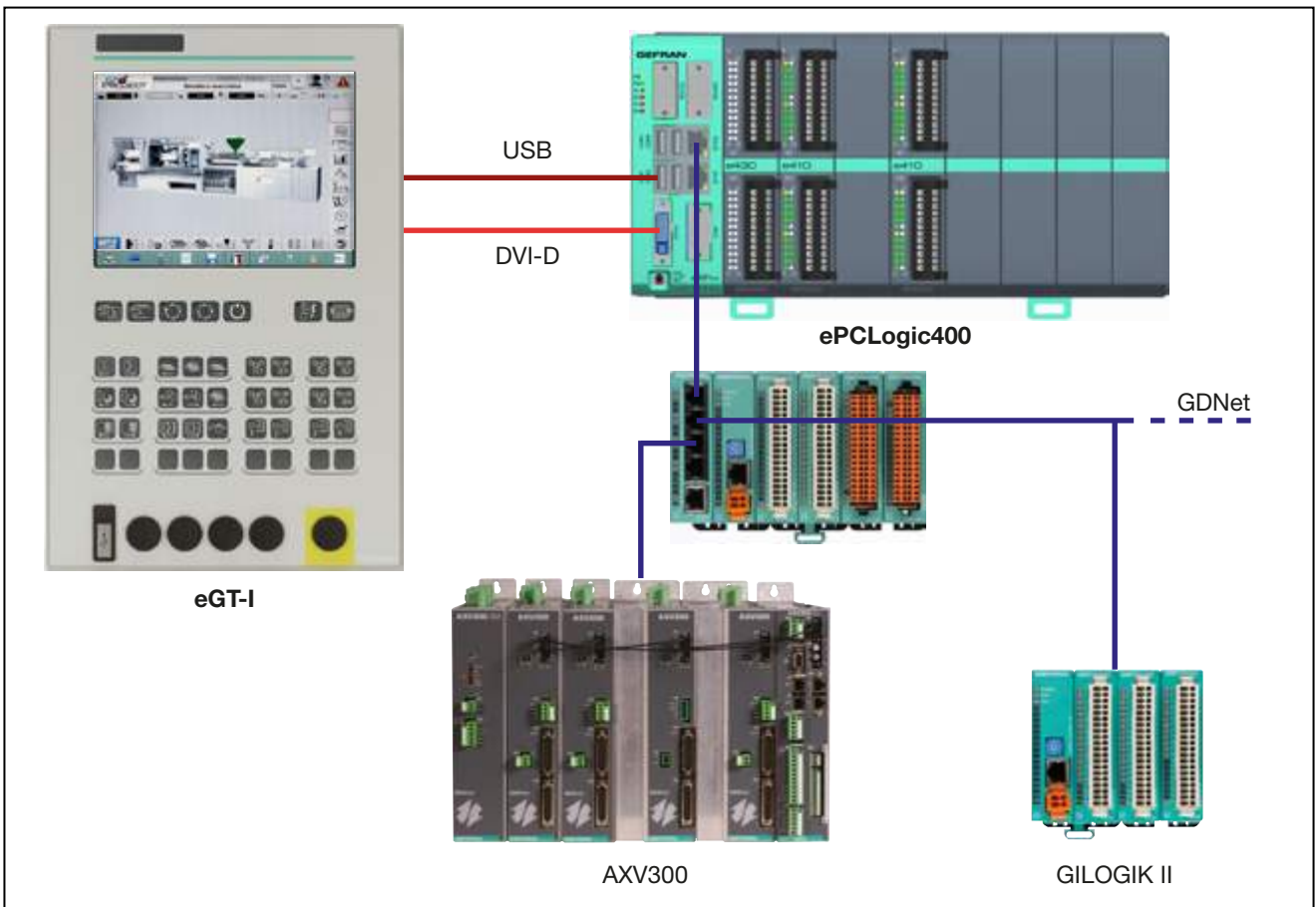

Figure 3 - GDNet System architecture

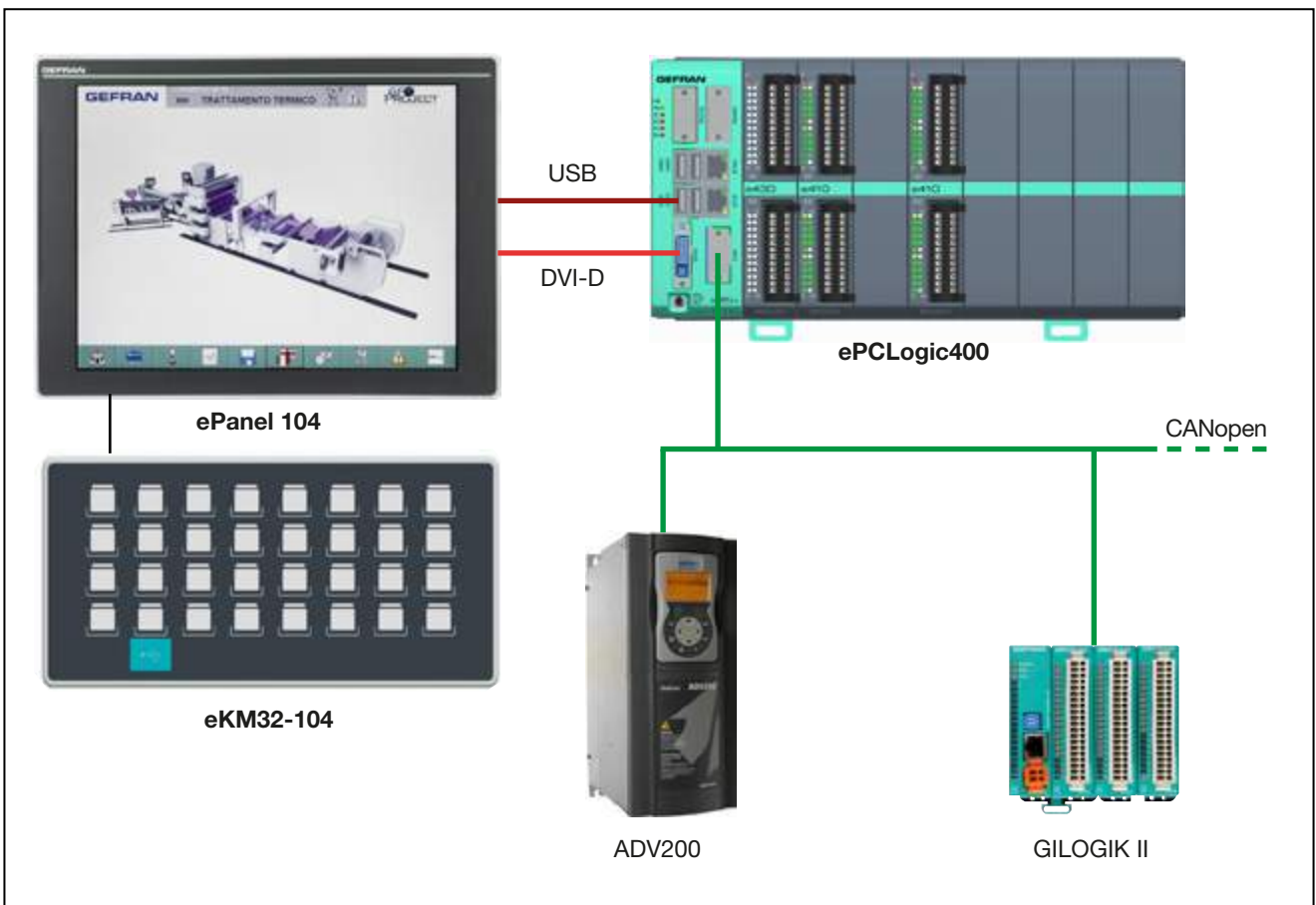

Figure 4 - CANopen System architecture

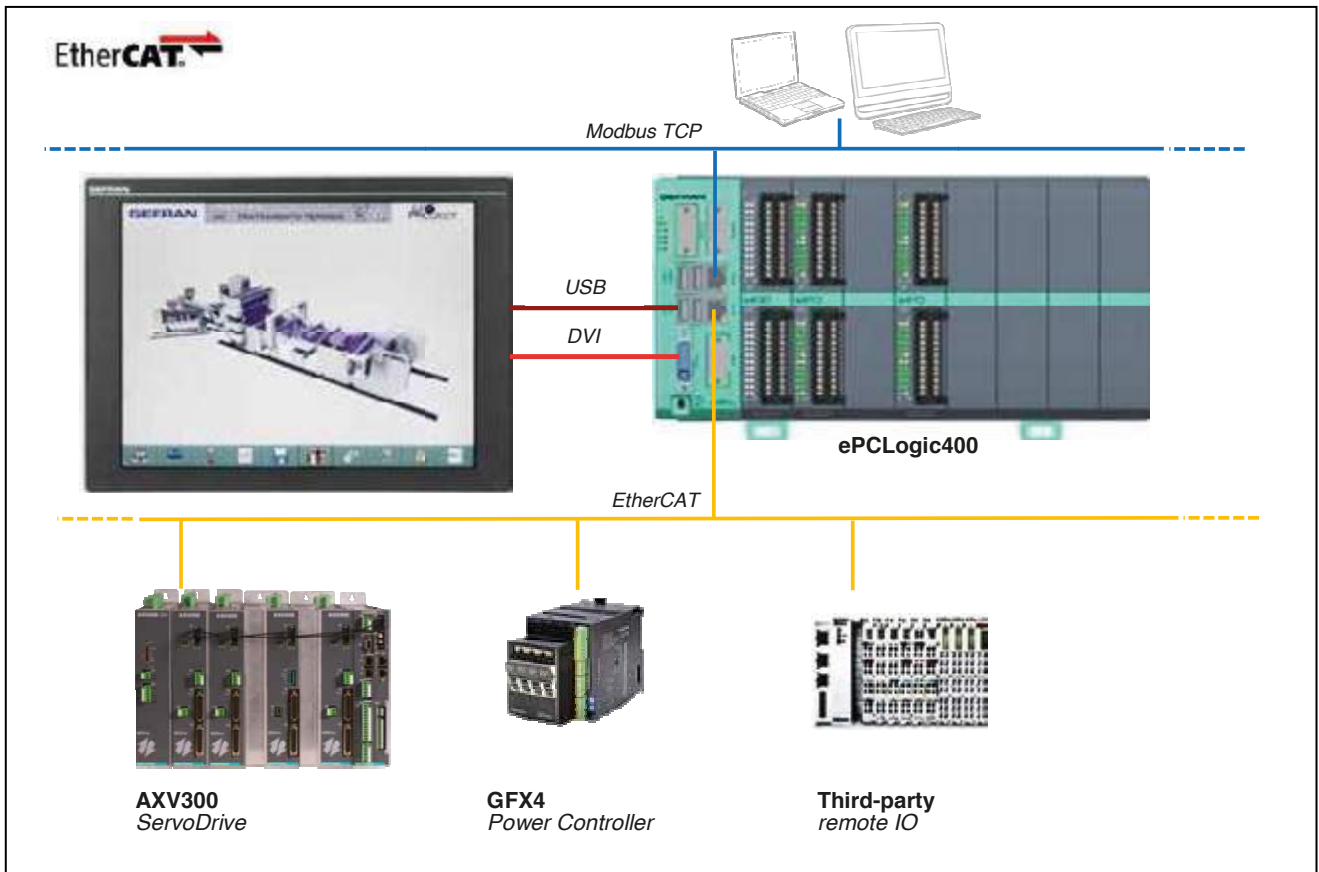

Figure 5 : EtherCAT System architecture

Main power supply

The system can be powered with ONE (1) power supply as shown in Figure 6.

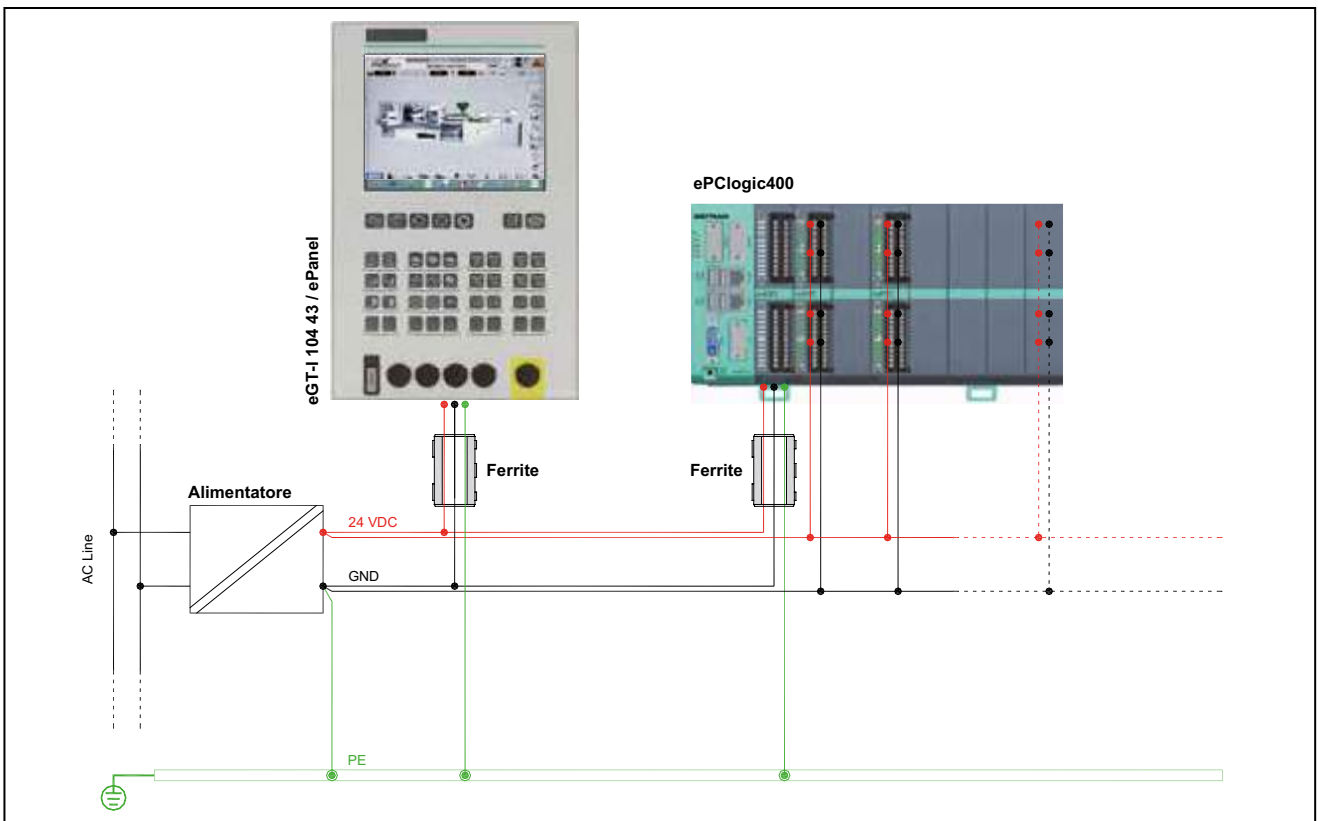

Figure 6 : Single power supply

- To power the system correctly, make sure that:
- The power supply has the power needed to run the system, I/Os, and any additional resources connected to it.
 - Ground the power supply (GND) with a wire that is straight and as short as possible (PE).
 - Ground the ePanel / eGT-I ground terminal and the ePCLoGic400 (GND) with a wire that is straight and as short as possible (PE).

- Insert the ferrites into the power supply cables as close as possible to the ePanel / eGT-I and the ePCLoGic400.
- Execute two separate power supply lines: one for the system and one for I/Os and auxiliary components.
- The system power supply line must have a different path from the plant and machine power cables.

The system can be powered with TWO (2) power supplies as shown in figure 7.

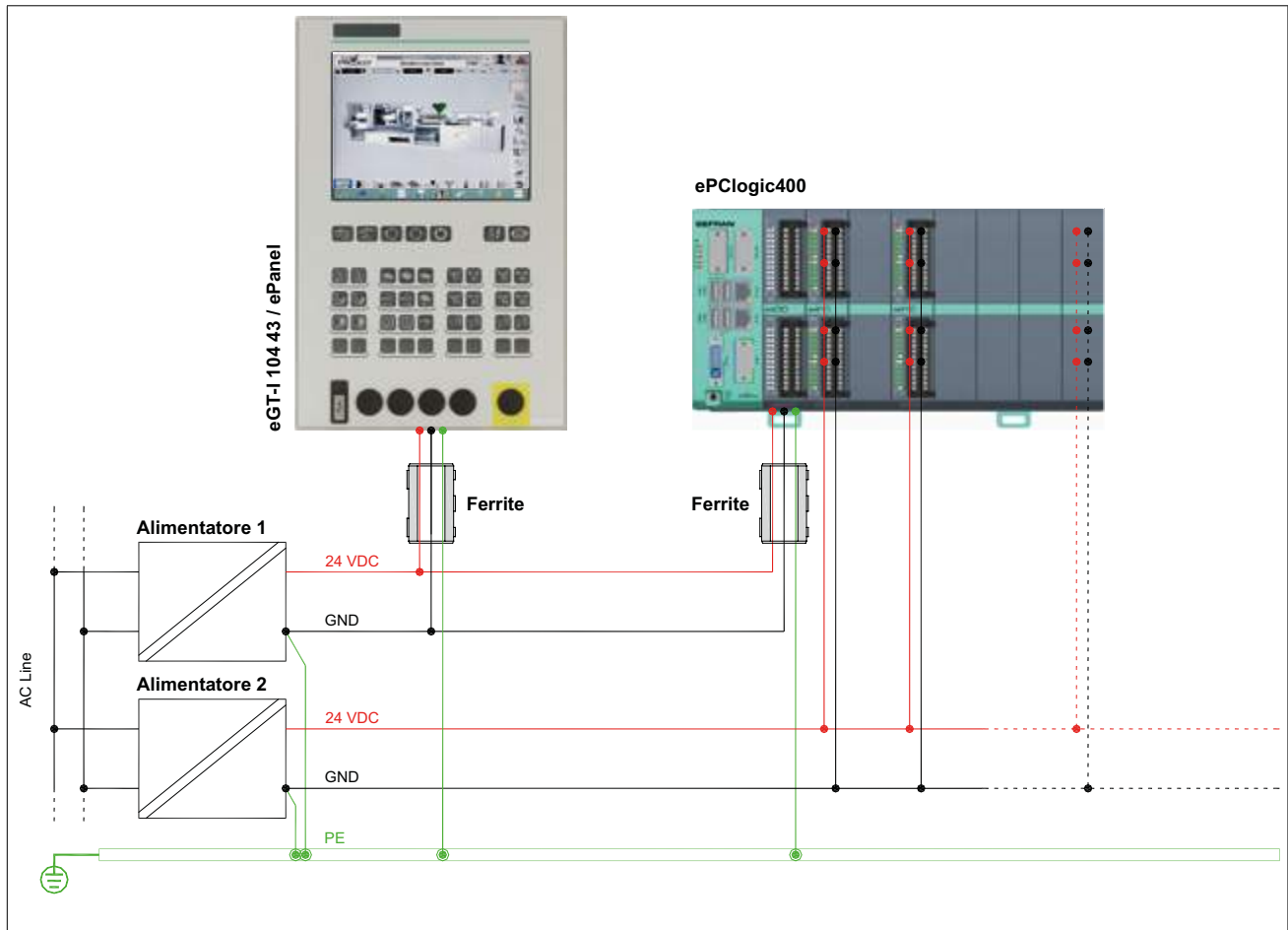

Figure 7 : Dual power supply

- To power the system correctly, make sure that:
- Power supply 1 has the power needed to run the system
 - Power supply 2 has the power needed to power the I/Os and any additional resources connected to it.
 - Ground the power supplies (GND) with a wire that is straight and as short as possible (PE).
 - Ground the ePanel / eGT-I ground terminal and the ePCLoGic400 (GND) with a wire that is straight and as short as possible (PE).

- Insert the ferrites into the power supply cables as close as possible to the ePanel / eGT-I and the ePCLoGic400.
- The Performa system power supply line must have a different path from the plant and machine power cables.

Order codes



The order code of the system ePCL400 must be composed by observing the following guidelines:

1. Selecting modules from left to right
2. Position 00 is reserved for the CPU modules
3. After the CPU module selects the analog modules, then the functional I/O modules, and finally the digital I/O modules.

00 01 02 03 04 05 06 07 08 *posizione*
ePCL400 0000 00 00 00 00 00 00 00 00 *sigla*

Functional I/O

3 0	6 analog inputs + 4 analog outputs + 8 temperature inputs (1 slot)
3 1	12 temperature inputs + 20 digital outputs

Digital I/O

1 0	16 digital inputs + 20 digital outputs (2 slots)
1 1	16 digital inputs + 16 digital outputs (single slot)

CPU: Intel Atom E620 (600 MHz) processor, 2 GB Flash memory, 512 MB RAM

9 1 0 0	IO ports: DVI-D, 1 x Ethernet, [Modbus TCP], 2 x USB
9 1 0 1	IO ports: DVI-D, 1 x Ethernet, [Modbus TCP], 2 x USB, 1 x RS485, 1 x RS232
9 1 0 2	IO ports: DVI-D, 1 x Ethernet, [Modbus TCP], 2 x USB, 1 x CAN
9 1 0 3	IO ports: DVI-D, 1 x Ethernet, [Modbus TCP], 2 x USB, 1 x RS485, 1 x RS232, 1 x CAN
9 1 0 4	IO ports: DVI-D, 2 x Ethernet, [Modbus TCP, GDNet], 4 x USB
9 1 0 5	IO ports: DVI-D, 2 x Ethernet, [Modbus TCP, GDNet], 4 x USB, 1 x RS485, 1 x RS232
9 1 0 6	IO ports: DVI-D, 2 x Ethernet, [Modbus TCP, GDNet], 4 x USB, 1 x CAN
9 1 0 7	IO ports: DVI-D, 2 x Ethernet, [Modbus TCP, GDNet], 4 x USB, 1 x RS485, 1 x RS232, 1 x CAN

CPU: Intel Atom E640 (1 GHz) processor, processor, 2 GB Flash memory, 512 MB RAM

9 2 0 0	IO ports: DVI-D, 1 x Ethernet, [Modbus TCP], 2 x USB
9 2 0 1	IO ports: DVI-D, 1 x Ethernet, [Modbus TCP], 2 x USB, 1 x RS485, 1 x RS232
9 2 0 2	IO ports: DVI-D, 1 x Ethernet, [Modbus TCP], 2 x USB, 1 x CAN
9 2 0 3	IO ports: DVI-D, 1 x Ethernet, [Modbus TCP], 2 x USB, 1 x RS485, 1 x RS232, 1 x CAN
9 2 0 4	IO ports: DVI-D, 2xEthernet [Modbus TCP, GDNet], 4xUSB
9 2 0 5	IO ports: DVI-D, 2xEthernet [Modbus TCP, GDNet], 4xUSB, 1xRS485 ,1xRS232
9 2 0 6	IO ports: DVI-D, 2xEthernet [Modbus TCP, GDNet], 4xUSB, 1xCAN
9 2 0 7	IO ports: DVI-D, 2xEthernet [Modbus TCP, GDNet], 4xUSB, 1xRS485 ,1xRS232, 1xCAN
9 2 0 8	IO ports: DVI-D, 2xEthernet [Modbus TCP, EtherCAT\GDNet], 4xUSB
9 2 0 9	IO ports: DVI-D, 2xEthernet [Modbus TCP, EtherCAT\GDNet], 4xUSB, 1xRS485 ,1xRS232
9 2 1 0	IO ports: DVI-D, 2xEthernet [Modbus TCP, EtherCAT\GDNet], 4xUSB, 1xCAN
9 2 1 1	IO ports: DVI-D, 2xEthernet [Modbus TCP, EtherCAT\GDNet], 4xUSB, 1xRS485 ,1x RS232, 1xCAN

CPU: Intel Atom E660 (1,3 GHz) processor, 2 GB Flash memory, 512 MB RAM

9 3 0 0	IO ports: DVI-D, 1 x Ethernet, [Modbus TCP], 2 x USB
9 3 0 1	IO ports: DVI-D, 1 x Ethernet, [Modbus TCP], 2 x USB, 1 x RS485, 1 x RS232
9 3 0 2	IO ports: DVI-D, 1 x Ethernet, [Modbus TCP], 2 x USB, 1 x CAN
9 3 0 3	IO ports: DVI-D, 1 x Ethernet, [Modbus TCP], 2 x USB, 1 x RS485, 1 x RS232, 1 x CAN
9 3 0 4	IO ports: DVI-D, 2xEthernet [Modbus TCP, GDNet], 4xUSB
9 3 0 5	IO ports: DVI-D, 2xEthernet [Modbus TCP, GDNet], 4xUSB, 1xRS485 ,1xRS232
9 3 0 6	IO ports: DVI-D, 2xEthernet [Modbus TCP, GDNet], 4xUSB, 1xCAN
9 3 0 7	IO ports: DVI-D, 2xEthernet [Modbus TCP, GDNet], 4xUSB, 1xRS485 ,1xRS232, 1xCAN
9 3 0 8	IO ports: DVI-D, 2xEthernet [Modbus TCP, EtherCAT\GDNet], 4xUSB
9 3 0 9	IO ports: DVI-D, 2xEthernet [Modbus TCP, EtherCAT\GDNet], 4xUSB, 1xRS485 ,1xRS232
9 3 1 0	IO ports: DVI-D, 2xEthernet [Modbus TCP, EtherCAT\GDNet], 4xUSB, 1xCAN
9 3 1 1	IO ports: DVI-D, 2xEthernet [Modbus TCP, EtherCAT\GDNet], 4xUSB, 1xRS485 ,1xRS232, 1xCAN

Example of order model number

Code	Model Number	Description
F057775	ePCL400-9100-30-10-00-10-00-00-00	Complete ePCLLogic400 system, consisting of rack with integrated power supply, Atom E620 600 MHz CPU with one DVI-D port, two USB ports, one Ethernet port. One 18-channel (6 analog inputs + 4 analog outputs + 8 temperature inputs) e430 functional I/O module Two 36-channel (16 inputs + 20 outputs) e410 digital I/O modules. Full frontal for unused slots.

Accessories

Code	Model Number	Description
F057774	eCON24	24-pin female connector,
F057674	CAV_DVI18	1,8 meter DVI-D cable
F057675	CAV_DVI50	5 meter DVI-D cable
F057676	CAV_USB_AB18	1.8 meter USB 2.0 cable, type A - type B connectors
F057677	CAV_USB_AB50	5 meter USB 2.0 cable, type A - type B connectors
F057679	USB_PEN1G	1 GB USB key
F057777	SD_CARD1GB	SD Card 1GB

Programming tool

GF_PROJECT VX

Development software that allows the writing of the application program for PLC with IEC1131 languages. Also allows the construction, in graphic mode, of the various pages of the user interface necessary to the application developed.

Via GF_PROJECT LX it is possible to connect to the device that will host the application to debug the program and upload the upgrades.

System requirements

	Minimum	Recommended
Operative system	Windows XP SP2 or Windows Vista or Windows 7 (32 bit)	Windows 7 (64 bit)
Processor	Intel Pentium 1 GHz	Intel Core i5 2,5 Ghz or superior
RAM	2 GB	4 GB or superior
Free space on Hard Disk	2 GB	4 GB or superior
Graphic resolution	XGA (1024 x 768 pixel)	SXGA (1280 x 1024 pixel) or superior
Browser	Microsoft Internet Explorer 8.0	Microsoft Internet Explorer 9.0
Ethernet Port	1 RJ45	1 RJ45
DVD player	Yes	Yes
USB port	1 USB 2.0	1 USB 2.0

ePanel Operator Panel

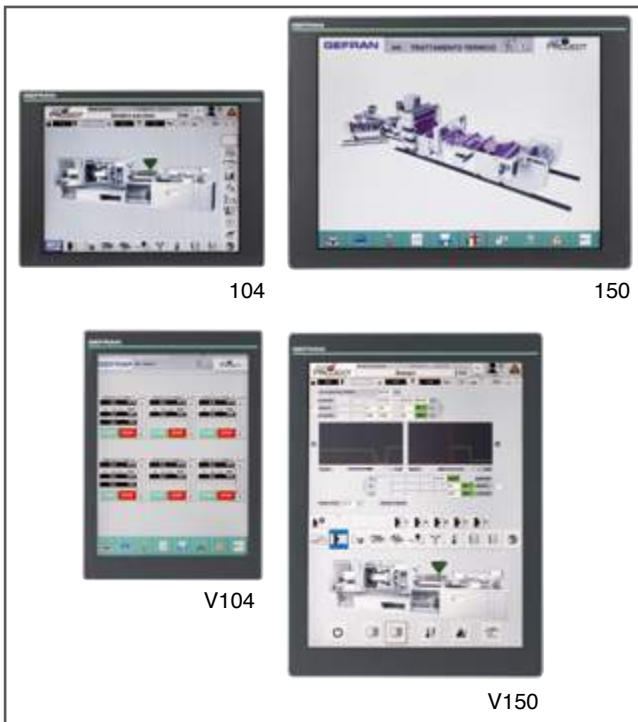

The ePanel Operator Panel, available in 4 versions, lets you display and set the automation data.

The operator uses a color touch screen.

Depending on the model, screen size can be 10.4" or 15", either horizontal or vertical.

The Operator Panel is connected to the Controller with a DVI-D cable and a USB cable.

Main characteristics:

- 10.4" and 15" color display with resistive touch screen
- vertical or horizontal installation
- IP65 front panel protection level
- two USB ports

Code	According to model (see order code)
Sigla	According to model (see order code)
Brief description	Operator Panel with display and resistive touch screen

Technical data

		104 - V104	150 - V150
POWER SUPPLY	Operating voltage	24 VDC $\pm 25\%$	
	Current draw (at 24 VDC)	400 mA max	750 mA max
	Power dissipation	9,6 W max	18 W max
	Protections	Polarity inversion Short circuit	
Connection	3-pin polarized removable connector Screw terminals, max cable section 2.5 mm ²		
CONNECTIONS	Video port	Connector: standard DVI-D Max cable length: 5 m	
	HOST USB port (Controller connection)	Connector: type B Max cable length: 5 m	
	USB port	Number: 1 Connector: type A Standard: USB 2.0 Max cable length: 1.8 m	
	KEY & LED port	Connector: RJ45 Standard: USB 2.0	
DISPLAY	Type	TFT with touch screen	
	Size (diagonal)	10,4"	15"
	Pixel resolution	104: 800 × 600 V104: 600 × 800	150: 1024 × 768 V150: 768 × 1024
	Screen area (L x H)	104: 211,2 × 158,4 mm V104: 158,4 × 211,2 mm	150: 304,1 × 228,1 mm V150: 228,1 × 304,1 mm
	Colors	262.144	
	Luminosity	230 cd/m ²	400 cd/m ²
	Contrast	500:1	700:1
	Backlighting	White LEDs life 30.000 ore @ 25 °C	White LEDs life 50.000 ore @ 25 °C
	Visual angle	Horizontal: 80° Vertical: 60°-70°	Horizontal: 80° Vertical: 60°-80°
CONFIGURATION ELEMENTS	Video	6 video control buttons (OSD menu) located on rear	
	Touch screen calibration	Via SW in control system	
CONTROL ELEMENTS	Touch screen	4-wire resistive technology	
AMBIENT CONDITIONS	Operating temperature	0 ... +55 °C (as per IEC 68-2-14)	
	Storage temperature	-20 ... +70 °C (as per IEC 68-2-14)	
	Relative humidity	max 95% RH non condnsing (as per IEC 68-2-3)	
	Vibrations	5 to 9 Hz: sine constant 3.5 mm 10 to 150 Hz: sine acceleration 1G	
ASSEMBLY		Built-in, in control boards or panels	
PROTECTION LEVEL		IP 65 on front panel (as per IEC 68-2-3)	
WEIGHT		1,45 kg	2,7 kg
CE STANDARDS	EMC (electromagnetic compatibility)	Conforms to Directive 2004/108/CE EMC Emission: EN 61000-6-4 EMC Immunity: EN 61131-2, EN 61000-4-2, EN 61000-4-3, EN 61000-4-4, EN 61000-4-5, EN 61000-4-6, EN 61000-4-8, EN 61000-4-11	
	LV (low voltage)	Conforms to Directive 2006/95/CE Safety LVD: EN 61010-1	

Dimensions and spaces required for installation

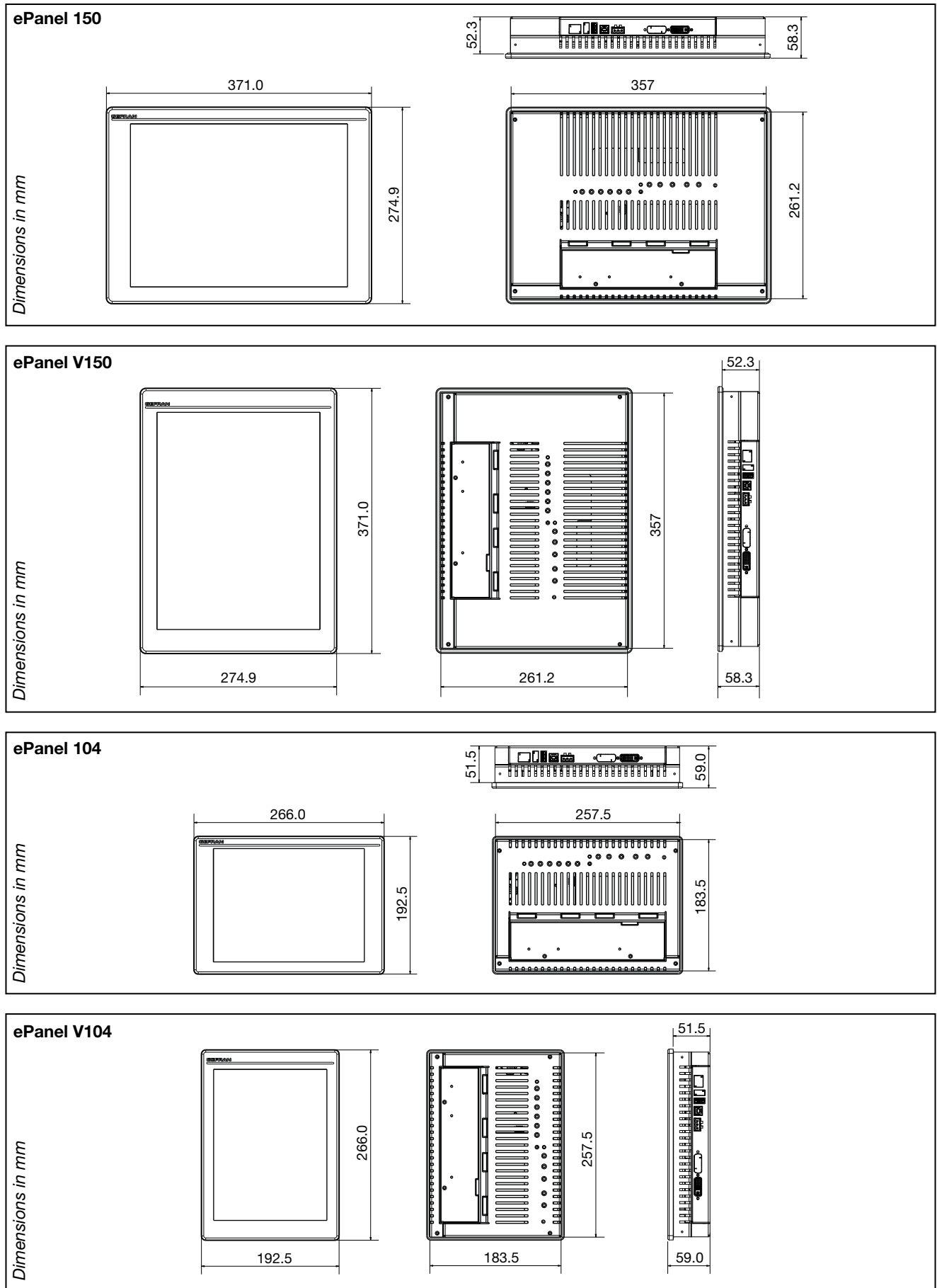

Figure 8 - Dimensions ePanel

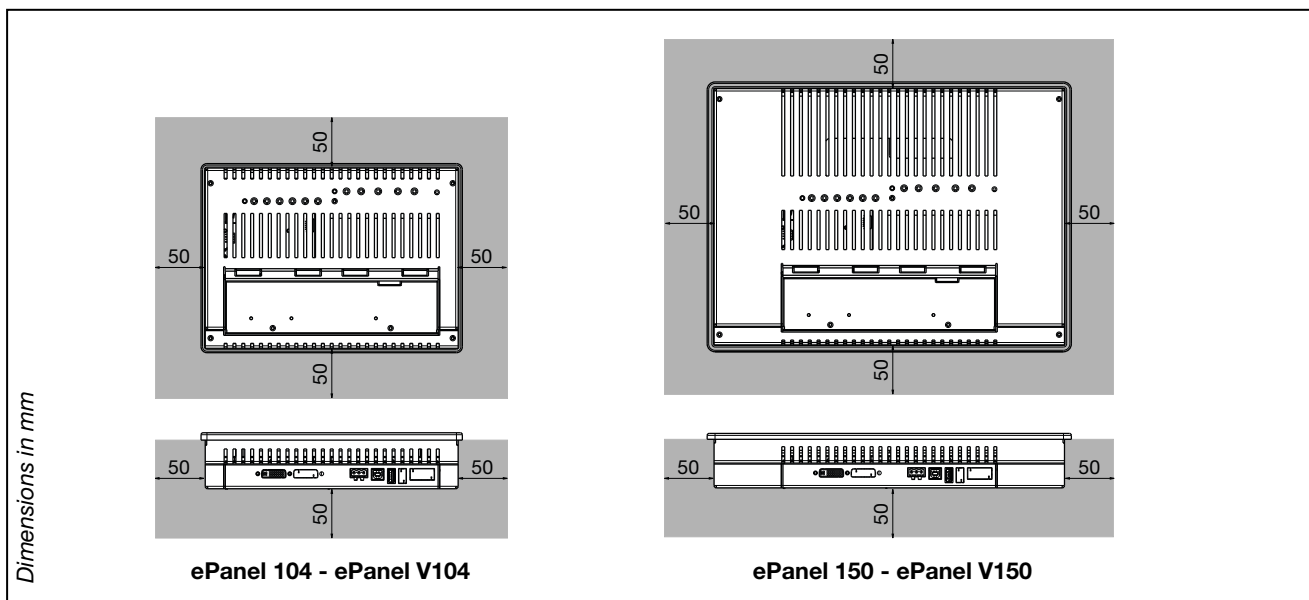

Figure 9 - Space for ventilation



Attention: the temperature in the compartment containing the Operator Panel must never exceed 55°C.

The open spaces shown in gray are recommended with static ventilation. These spaces may be reduced with forced ventilation

Order codes

Code	Model Number	Description
F056417	ePanel 104	Operator Panel. 10.4" color display with resistive touch screen. Two USB ports (1 × host, 1 × device). Horizontal installation.
F056418	ePanel V104	Operator Panel. 10.4" color display with resistive touch screen. Two USB ports (1 × host, 1 × device). Vertical installation.
F056421	ePanel 150	Operator Panel. 15" color display with resistive touch screen. Two USB ports. (1 × host, 1 × device). Horizontal installation.
F056422	ePanel V150	Operator Panel. 15" color display with resistive touch screen. Two USB ports. (1 × host, 1 × device). Vertical installation.

Accessories

Code	Model Number	Description
F057776	KIT_INSTA	Installation kit (fastening blocks + ferrite + power supply connector)
F057674	CAV_DVI18	1.8 meter DVI-D cable
F057675	CAV_DVI50	5 meter DVI-D cable
F057676	CAV_USB_AB18	1.8 meter USB 2.0 cable, type A - type B connectors
F057677	CAV_USB_AB50	5 meter USB 2.0 cable, type A - type B connectors
F057679	USB_PEN1G	1 GB USB key

eGT-I OPERATOR PANEL



eGT-I 104-43

The eGT-I Operator Panel is designed for plastic/rubber injection machines, and displays and sets process and configuration data.

The operator uses a 10.4" color touch screen with 43 keys (34 preset and 9 programmable).

The preset keys give the operator direct access to the most common functions, such as setting machine mode (manual, automatic, etc.), mould opening/closing, etc.

The front panel has a USB 2.0 port for connection with data import/export functions via USB key.

The Operator Panel is connected to the Controller with a DVI-D cable and a USB cable

Applications:

- Plastic, injection machines

Main characteristics:

- designed for plastic/rubber injection machines
- 10.4" color display with resistive touch screen for machines
- integrated keyboard for manual movements and settings machine
- front panel USB 2.0 port for easy data transfer
- IP54 front panel protection degree
- provision for electromechanical buttons
- removable labels for customization (9 buttons)
- label logo.

Code	F058480
Model Number	eGT-I 104-43
Description	Operator interface with LCD 10.4 "resistive touch screen, keyboard machines for injection

Technical Data

POWER SUPPLY	Operating voltage	24 VDC \pm 25%
	Current draw (at 24 VDC)	800 mA max
	Power dissipation	19 W max
	Protections	Polarity inversion Short circuit
	Connection	3-pin polarized removable connector Screw terminals, max cable section 2.5 mm ²
PROVISIONS		5 holes on front panel, \varnothing 22 mm, suitable for electromechanical buttons or switches. Yellow serigraphy for emergency button
CONNECTIONS	Video port (Controller connection)	Connector: standard DVI-D Max cable length: 5 m
	HOST USB port (Controller connection)	Connector: type B Max cable length: 5 m
	USB port	Number: 2 (1 front with protection, 1 rear) Connector: type A Standard: USB 2.0 Max cable length: 1.8 m
DISPLAY	Type	TFT with touch screen
	Size (diagonal)	10,4"
	Pixel resolution	800 x 600
	Screen area (L x H)	211,2 x 158,4 mm
	Colors	262.144
	Luminosity	230 cd/m ²
	Contrast	500:1
	Backlighting	White LEDs life 30.000 hours @ 25 °C
Visual angle	Horizontal: 80° Vertical: 60°-70°	
INPUTS	Number	10
	Type	Voltage-free contact
	Use	Combined with electromechanical buttons or switches
CONFIGURATION ELEMENTS	Video	6 video control buttons (OSD menu) located on rear
	Touch screen calibration	Via SW in control system (ePCLogic400)
CONTROL ELEMENTS	Touch screen	4-wire resistive technology
	Keys	34 preset (6 with signal LEDs) 9 programmable
AMBIENT CONDITIONS	Operating temperature	0 ... +55 °C (as per IEC 68-2-14)
	Storage temperature	-20 ... +70 °C (as per IEC 68-2-14)
	Relative humidity	max 95% RH non-condensing (as per IEC 68-2-3)
	Vibrations	5 to 9 Hz: sine constant 3.5 mm 10 to 150 Hz: sine acceleration 1G
ASSEMBLY		Built-in, in control boards or panels
PROTECTION LEVEL		IP54 on front panel (as per IEC 68-2-3)
WEIGHT		2.4 kg
CE STANDARDS	EMC (electromagnetic compatibility)	Conforms to Directive 2004/108/CE EMC Emission: EN 61000-6-4 EMC Immunity: EN 61131-2, EN 61000-4-2, EN 61000-4-3, EN 61000-4-4, EN 61000-4-5, EN 61000-4-6, EN 61000-4-8, EN 61000-4-11
	LV (low voltage)	Conforms to Directive 2006/95/CE Safety LVD: EN 61010-1

Dimensions and spaces required for installation

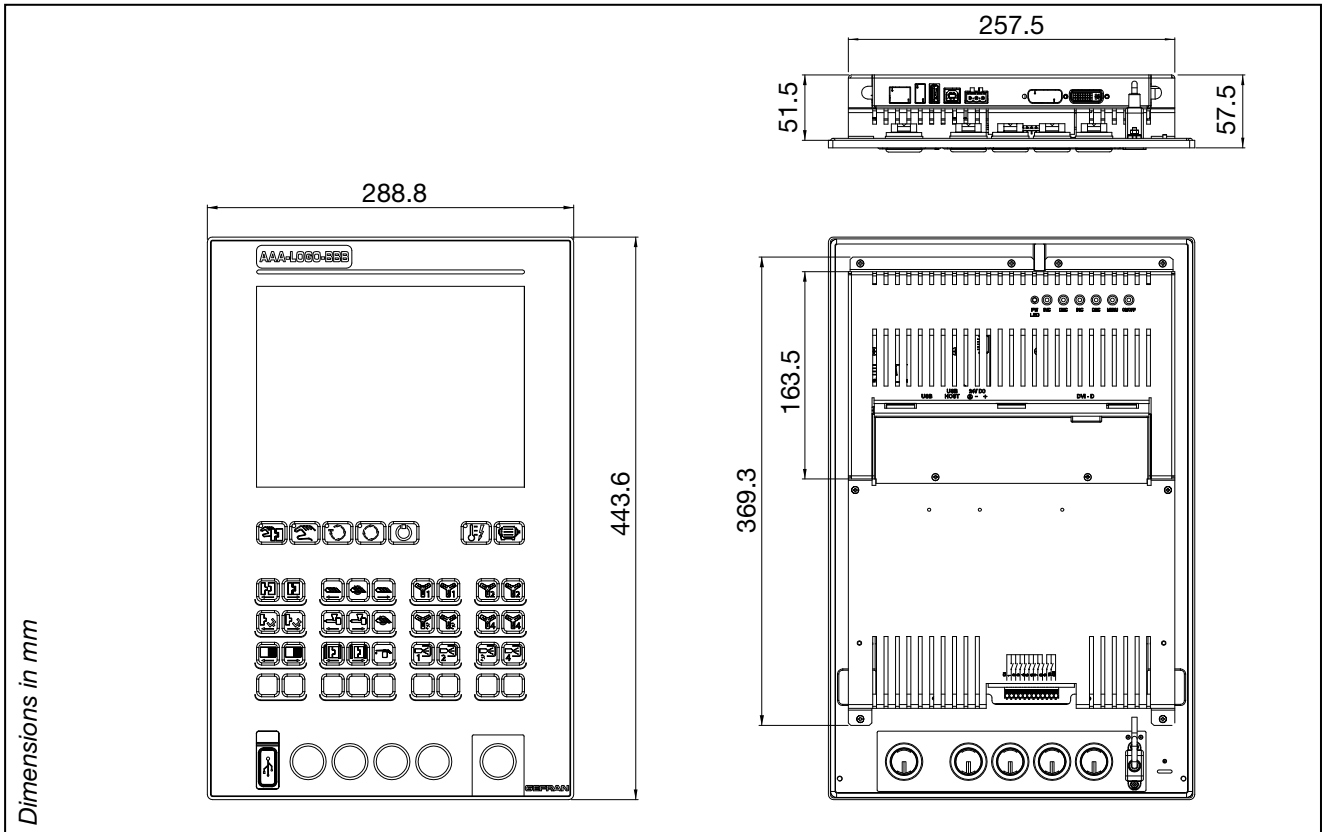

Figure 10 - Dimensions eGT-I

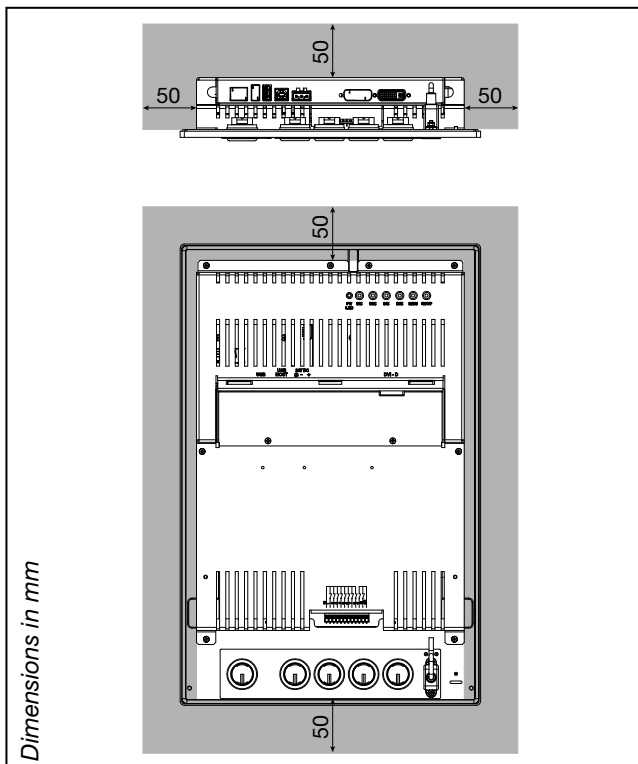

Figure 11 - Space for ventilation.



Warning: the temperature in the compartment containing the Operator Interface must never exceed 55°C.

The open spaces shown in gray are recommended with static ventilation.

These spaces may be reduced with forced ventilation.

Order codes

Code	Model Number	Description
F058480	eGT-I 104-43	Operator Panel to display and set data for plastic injection machines. 10.4" display with touch screen. Specific keyboard for machine functions with dedicated icons (43 keys, of which 6 complete with status LED). 9 keys are freely configurable with removable labels.

Accessories

Code	Model Number	Description
F057776	KIT_INSTA	Installation kit (fastening blocks + ferrite + power supply connector)
F057674	CAV_DVI18	1.8 meter DVI-D cable
F057675	CAV_DVI50	5 m meter DVI-D cable
F057676	CAV_USB_AB18	1.8 meter USB 2.0 cable, type A - type B connectors
F057677	CAV_USB_AB50	5 meter USB 2.0 cable, type A - type B connectors
F057678	SET_LES01	Set of blank labels (one strip of 4 labels, one strip of 5 labels, one strip for logo)
F057679	USB_PEN1G	USB 1GB key

eKM32-104 KEYBOARD

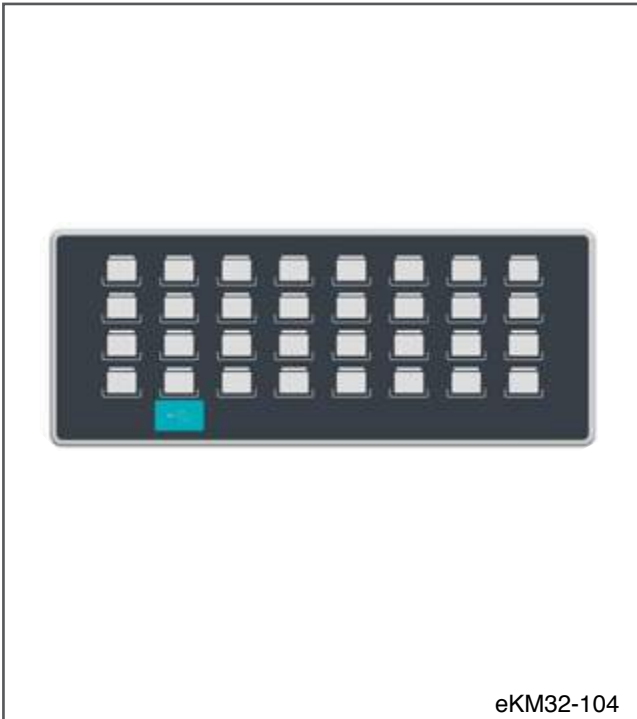

The eKM32-104 keyboard couples with ePanel series operator panels.
The function of all of the keyboard buttons and LEDs can be customized.
The front of the keyboard has a USB 2.0 port to connect USB drives for data import/export.
The rear has 16 inputs for additional external auxiliary keys

Main applications:

- plastics, injection machines

Main characteristics:

- 32 keys.
- 32 LEDs.
- 16 external auxiliary keys.
- Customizable keys (function and symbol).
- Removable labels for customization.
- Front panel USB 2.0 port for easy data transfer.

Code	According to model: see order codes
Model Number	According to model: see order codes
Description	32-key keyboard, 32 LEDs for machine movements

Technical data

POWER SUPPLY	Supply voltage	Supplied directly via the keyboard and operator panel connection cable
	Connection	RJ45 Connector
CONNECTIONS	Communication and power supply	Connettore: RJ45 Connector Standard: USB 2.0 standard Cable: Ethernet CAT 5e, L=1 m, included
CONTROL ELEMENTS	Keys	
	Number	32
	Function	Customizable via software
	Type	Done
	No. Operations	> 2.000.000
	Dimensions	17x14 mm
	LEDs	
	Number	32
	Function	Customizable via software
AMBIENT CONDITIONS	Operating temperature	0 ... +55 °C (as per IEC 68-2-14)
	Storage temperature	-20 ... +70 °C (as per IEC 68-2-14)
	Relative humidity	max 95% RH non-condensing (as per IEC 68-2-3)
	Vibrations	5 to 9 Hz: sine constant 3.5 mm 10 to 150 Hz: sine acceleration 1G
ASSEMBLY		Built-in, in control boards or panels
PROTECTION LEVEL		IP65, faceplate IP 20, rear
WEIGHT		0,470 kg
CE STANDARDS	EMC (electromagnetic compatibility)	Conforms to Directive 2004/108/CE EMC Emission: EN 61000-6-4 EMC Immunity: EN 61131-2, EN 61000-4-2, EN 61000-4-3, EN 61000-4-4, EN 61000-4-5, EN 61000-4-6, EN 61000-4-8, EN 61000-4-11
	Conformità BT (low voltage)	Conforms to Directive 2006/95/CE LVD: EN 61010-1 safety

Dimensions and spaces required for installation

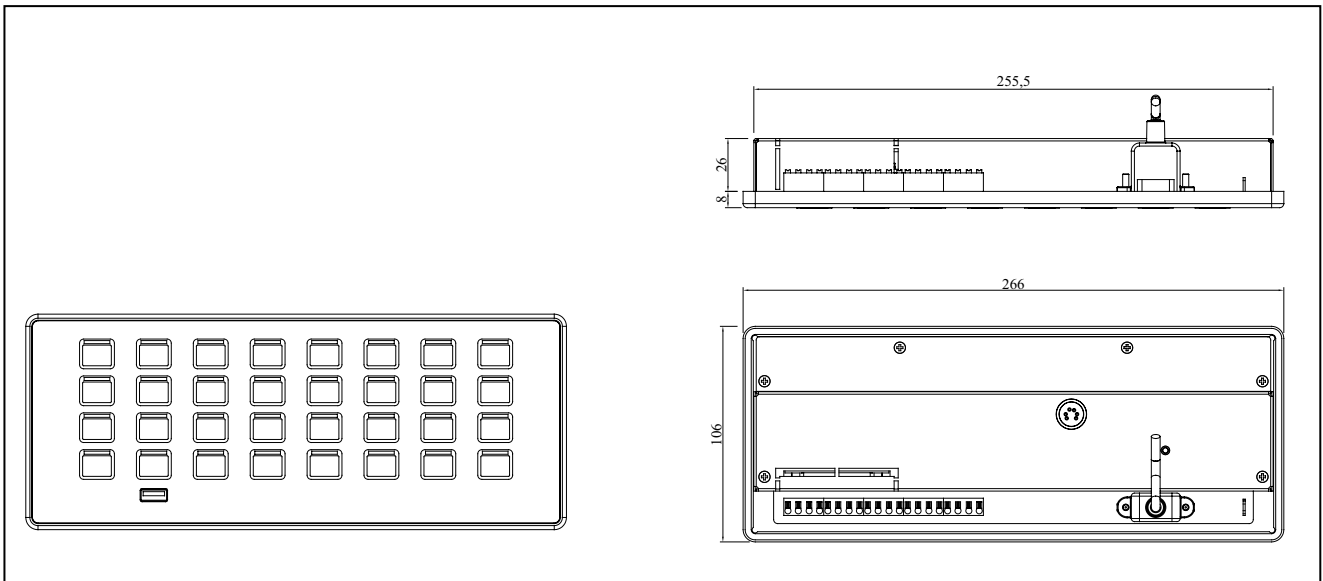

Figure 12 - Dimensions eKM32-104



Warning: the temperature in the compartment containing the eKM32-104 keypad must never exceed 55 °C.

Order codes

Code	Model Number	Description
F061352	eKM32-104-N0-G0	32-key keyboard 32 LEDs with neutral key labels
F060589	eKM32-104-I0-G0	32-key keyboard 32 LEDs with injection key labels

RACK FOR SYSTEM ePCLoGic400



e4R08

The rack consists of a plastic case that houses the power supply and the back-plane with slots for the CPU module and the I/O modules, both available in various models.

The rack installs on a standard 35 mm DIN bar.

A temperature probe on the rack measures the system's internal temperature.

Main characteristics:

- plastic rack installs on standard 35 mm DIN bar
- houses 1 CPU module and up to 8 digital or analog I/O modules
- backplane for CPU-module connections and module power supply
- temperature probe in case measures system's internal temperature.

Code	F057555
Model Number	e4R08
Description	Rack system for ePCLoGic400. Complete with power supply and backplane can accommodate 1 CPU and 8 I / O modules

Technical data

POWER SUPPLY	Operating voltage	24 VDC \pm 25%
	Current draw (at 24 VDC)	2,5 A max
	Power dissipation	14 W max
	Connection	3-pin removable polarized terminal board
	Electrical isolation	CPU Bus: yes IO Bus: no
	Protections	Polarity inversion Short circuit Overload
CONNECTIONS	Modules	Number of slots: 9 (1 x CPU + 8 x I/O) Female card-edge connector
CONTROL ELEMENTS	Temperature	Internal temperature control sensor Warning via software
AMBIENT CONDITIONS	Operating temperature	0 ... +50 °C (as per IEC 68-2-14)
	Storage temperature	-20 ... +70 °C (as per IEC 68-2-14)
	Relative humidity	max 90% RH non-condensing (as per IEC 68-2-3)
ASSEMBLY		On DIN 35 mm bar, with snap hooks Horizontal position only, in panel
PROTECTION LEVEL		IP20
WEIGHT		0,75 kg
CE STANDARD	EMC (electromagnetic compatibility)	Conforms to Directive 2004/108/CE EMC Emission: EN 61000-6-4 EMC Immunity: EN 61131-2, EN 61000-4-2, EN 61000-4-3, EN 61000-4-4, EN 61000-4-5, EN 61000-4-6, EN 61000-4-8, EN 61000-4-11
	LV (low voltage)	Conforms to Directive 2006/95/CE Safety LVD: EN 61010-1

CPU MODULE series eCPU400 model e491xx

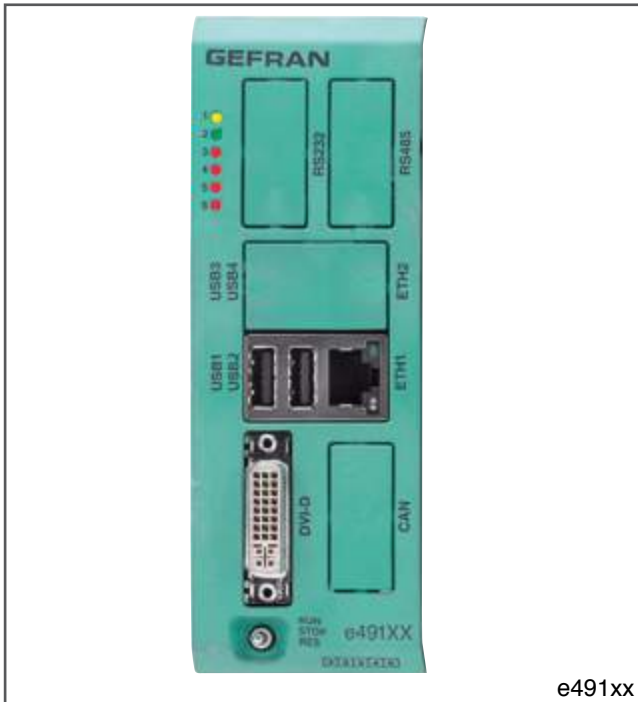

e491xx

The eCPU400 series model e491xx CPU module manages the PLC and graphic.

It installs in the first slot on the left of the rack.

It is powered by the back-plane, which connects it to the I/O modules.

The front of the module has a standard DVI-D output and ports for connections to the operator interface, to the Ethernet, and to other devices and buses.

Available with 600 MHz ATOM E620 processor

Main characteristics:

- management of PLC and graphic
- standard IEC 61131-3 programming: complete support of all languages
- powered by rack back-plane
- no maintenance: fanless; no moving parts
- high data storage capacity: 2 GB solid state mass memory
- basic model with DVI-D port, two USB ports and one Ethernet
- fieldbus options: second Ethernet port for Modbus TCP GDNNet (Fast Ethernet) communication; CAN port for CANopen Master communication
- serial options: one RS485 port and one RS232 port.
- available SD card slot for data storage (ordered separately).

Code	According to model (see order code)
Model Number	e491xx (see order code)
Description	CPU module to manage PLC and graphic. 600 MHz Intel Atom E620 processor
Position rack	In the first slot on the left, dedicated fixed position

Technical data

POWER SUPPLY	Internal	via back-plane
	Power Dissipation	15 W max
BACKUP BATTERY	Type	ML2032, rechargeable Li-AI 3 V 65 mAh, non-replaceable
	Life	10 years; 3 months without power supply
CONNECTIONS	Rack	Card-edge
	Video output	Connector: DVI-D Intel integrated 2D/3D graphic interface Resolution: settable via software (800×600 or 1024×768) Max. connection distance: 5 meters
	Ethernet (ETH) port	Number of channels: 2 max (1 optional) Connector: RJ45 Speed: 10 / 100 / 1000 Mbit/s Signals: green connection LED, yellow data LED
	RS-485 port (optional)	Optically isolated Connector: DB9 M Speed: 9,6 kbit/s ... 19,2 kbit/s Termination and polarizations: internal
	USB port	Number of ports: 4 max (2 optional) Connector: type A Standard: USB 2.0 Protection: overload
	CAN port (optional)	Optically isolated Connector: DB9M Speed: 20,50,100,125,250,500,1000 kbit/s, default 500 kbit/s Termination: external
	RS-232 port (optional)	Connector: DB9 M Speed: 1.2 kbit/s ... 115 kbit/s
COMMUNICATION PROTOCOLS	Ethernet	FTP (File Transfer Protocol) Modbus TCP/IP Master/Slave
	CAN	CANopen Master
	Modbus	Modbus RTU Master/Slave
	GNet	GNet Master (Real Time Fast Ethernet)
CONFIGURATION ELEMENTS	Software procedure access	16-position rotary selector
	PLC management	3-position selector *
DISPLAY ELEMENTS	Diagnostics	LED PW (yellow): power ON LED RN (green): PLC program status LED E1 (red): bus error local I/O LED E2 (red): Watchdog HW status LED E3 (red): Watchdog SW status LED E4 (red): PLC program status
MICROPROCESSORS	Type and frequency	ATOM E620, 600 MHz
MEMORY	System	512 MB, DRAM type DDRII
	Mass	2 GB Flash memory
	Mass memory extension	SD Card Slot **
AMBIENT CONDITIONS	Operating temperature	0 ... +50 °C (as per IEC 68-2-14)
	Storage temperature	-20 ... +70 °C (as per IEC 68-2-14)
	Relative humidity	max 95% RH non-condensing (as per IEC 68-2-3)
ASSEMBLY		On rack, with snap hooks
PROTECTION LEVEL		IP20
WEIGHT		0.5 kg
CE STANDARDS	EMC (electromagnetic compatibility)	Conforms to Directive 2004/108/CE EMC Emission: EN 61000-6-4 EMC Immunity: EN 61131-2, EN 61000-4-2, EN 61000-4-3, EN 61000-4-4, EN 61000-4-5, EN 61000-4-6, EN 61000-4-8, EN 61000-4-11
	LV (low voltage)	Conforms to Directive 2006/95/CE Safety LVD: EN 61010-1

* Currently not managed.

** SD Card not included, available as accessory.

Order code

CPU modules series eCPU400 model e491xx, Intel Atom E620 CPU (600 MHz), 512 MB RAM, 2 GB Flash memory.

Code	Model Number	Description
F057530	e49100	Communication peripherals: DVI-D, 1 × Ethernet [Modbus TCP], 2 × USB.
F057531	e49101	Communication peripherals: DVI-D, 1 × Ethernet [Modbus TCP], 2 × USB, 1 × RS485, 1 × RS232
F057532	e49102	Communication peripherals DVI-D, 1 × Ethernet [Modbus TCP], 2 × USB, 1 × CAN
F057533	e49103	Communication peripherals: DVI-D, 1 × Ethernet [Modbus TCP], 2 × USB, 1 × RS485, 1 × RS232, 1 × CAN
F057534	e49104	Communication peripherals DVI-D, 2 × Ethernet [Modbus TCP, GDNNet], 4 × USB
F057535	e49105	Communication peripherals: DVI-D, 2 × Ethernet [Modbus TCP, GDNNet], 4 × USB, 1 × RS485, 1 × RS232
F057536	e49106	Communication peripherals: DVI-D, 2 × Ethernet [Modbus TCP, GDNNet], 4 × USB, 1 × CAN
F057537	e49107	Communication peripherals DVI-D, 2 × Ethernet [Modbus TCP, GDNNet], 4 × USB, 1 × RS485, 1 × RS232, 1 × CAN

The following codes refer to single CPU modules. See the system documentation for the complete system.

Accessories

Code	Model Number	Description
F057777	SD_CARD1GB	SD Card
F057674	CAV_DVI18	1.8 meter DVI-D cable
F057675	CAV_DVI50	5 meter DVI-D cable
F057676	CAV_USB_AB18	1.8 meter USB 2.0 cable, type A - type B connectors
F057677	CAV_USB_AB50	5 meter USB 2.0 cable, type A - type B connectors
F057679	USB_PEN1G	USB 1GB key

CPU MODULE series eCPU400 model e492xx

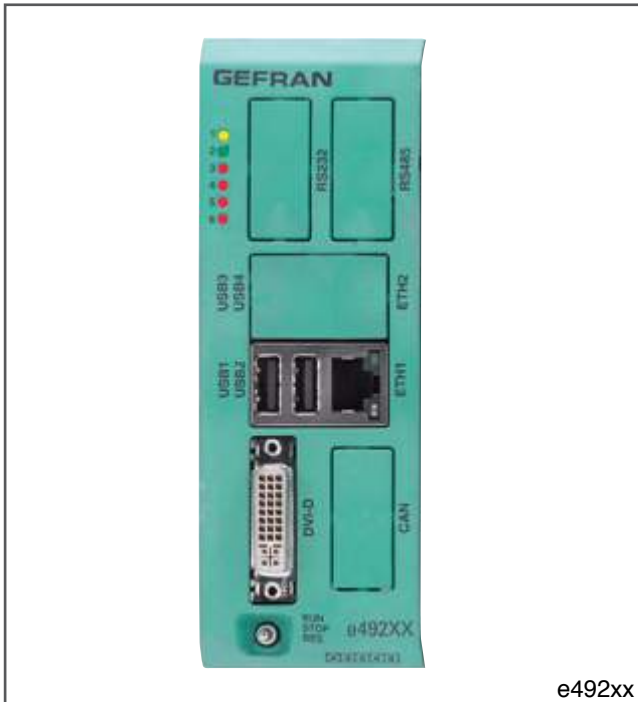

e492xx

The eCPU400 series model e492xx CPU module manages pages and the PLC.

It installs in the first slot on the left of the rack.

It is powered by the back-plane, which connects it to the I/O modules.

The front of the module has a standard DVI-D output and ports for connections to the operator interface, to the Ethernet, and to other devices and buses.

Available with ATOM E640 processor, frequency 1 GHz.

Main characteristics:

- Management of PLC and display
- Standard IEC 61131-3 programming: complete support of all languages
- Powered by rack back-plane
- No maintenance: fanless; no moving parts
- High data storage capacity: 4 GB solid state mass memory
- Basic model with DVI-D port, two USB ports and one Ethernet
- Fieldbus options: second Ethernet port for Modbus TCP, GDNNet Master and EtherCAT Master communication; CAN port for CANopen Master communication
- Serial options: one RS485 port and one RS232 port..

Code	According to model (see order code)
Model Number	e492xx (see order code)
Description	CPU module to manage PLC and display. 1 GHz Intel Atom E640 processor
Position rack	In the first slot on the left, dedicated fixed position

Technical data

POWER SUPPLY	Internal	via back-plane
	Power Dissipation	15 W max
BACKUP BATTERY	Type	ML2032, rechargeable Li-AI 3 V 65 mAh, non-replaceable
	Life	10 years; 3 months without power supply
CONNECTIONS	Rack	Card-edge
	Video output	Connector: DVI-D Intel integrated 2D/3D graphic interface Resolution: settable via software (800x600 or 1024x768) Max. connection distance: 5 m
	Ethernet (ETH) port	Number of channels: 2 max (1 optional) Connector: RJ45 Speed: 10 / 100 / 1000 Mbit/s Signals: green connection LED, yellow data LED
	RS-485 port (optional)	Optically isolated Connector: DB9 M Speed: 9,6 kbit/s ... 19,2 kbit/s Termination and polarizations: internal
	USB port	Number of ports: 4 max (2 optional) Connector: type A Standard: USB 2.0 Protection: overload
	CAN port (optional)	Optically isolated Connector: DB9M Speed: 20,50,100,125,250,500,1000kbit/s, default 500kbit/s Termination: external
	RS-232 port (optional)	Connector: DB9 M Speed: 1.2 kbit/s ... 115 kbit/s
COMMUNICATION PROTOCOLS	Ethernet	FTP (File Transfer Protocol) Modbus TCP/IP Master/Slave
	CAN	CANopen Master
	Modbus	Modbus RTU Master/Slave
	GDNet	GDNet Master (Real Time Fast Ethernet)
	EtherCAT	EtherCAT Master
CONFIGURATION ELEMENTS	Software procedure access	16-position rotary selector
	PLC management	3-position selector *
DISPLAY ELEMENTS	Diagnostics	LED PW (yellow): power ON LED RN (green): PLC program status LED E1 (red): error bus I/O local LED E2 (red): Watchdog HW status LED E3 (red): Watchdog SW status LED E4 (red): PLC program status
MICROPROCESSOR	Type and frequency	ATOM E640, 1 GHz
MEMORY	System	512 MB, DRAM tipo DDRII
	Mass	2 GB Flash memory
	Mass memory extension	Slot SD Card **
AMBIENT CONDITIONS	Operating temperature	0 ... +50 °C (as per IEC 68-2-14)
	Storage temperature	-20 ... +70 °C (as per IEC 68-2-14)
	Relative humidity	max 95% RH non-condensing (as per IEC 68-2-3)
ASSEMBLY		On rack, with snap hooks
PROTECTION LEVEL		IP20
WEIGHT		0.5 kg
CE STANDARDS	EMC (electromagnetic compatibility)	Conforms to Directive 2004/108/CE EMC Emission: EN 61000-6-4 EMC Immunity: EN 61131-2, EN 61000-4-2, EN 61000-4-3, EN 61000-4-4, EN 61000-4-5, EN 61000-4-6, EN 61000-4-8, EN 61000-4-11
	LV (low voltage)	Conforms to Directive 2006/95/CE Safety LVD: EN 61010-1

* Currently not managed.

** SD Card not included, available as accessory.

Order code

CPU modules series eCPU400 model e492xx, Intel Atom E640 CPU (1 GHz), 512 MB RAM, 2 GB Flash memory

Code	Model Number	Description
F057538	e49200	Communication peripherals: DVI-D, 1 × Ethernet [Modbus TCP], 2 × USB
F057539	e49201	Communication peripherals: DVI-D, 1 × Ethernet [Modbus TCP], 2 × USB, 1 × RS485, 1 × RS232
F057540	e49202	Communication peripherals: DVI-D, 1 × Ethernet [Modbus TCP], 2 × USB, 1 × CAN
F057541	e49203	Communication peripherals: DVI-D, 1 × Ethernet [Modbus TCP], 2 × USB, 1 × RS485, 1 × RS232, 1 × CAN
F057542	e49204	Communication peripherals: DVI-D, 2 × Ethernet [Modbus TCP, GDNet], 4 × USB
F057543	e49205	Communication peripherals: DVI-D, 2 × Ethernet [Modbus TCP, GDNet], 4 × USB, 1 × RS485, 1 × RS232
F057544	e49206	Communication peripherals: DVI-D, 2 × Ethernet [Modbus TCP, GDNet], 4 × USB, 1 × CAN
F057545	e49207	Communication peripherals: DVI-D, 2 × Ethernet [Modbus TCP, GDNet], 4 × USB, 1 × RS485, 1 × RS232, 1 × CAN
F064964	e49208	Communication peripherals: DVI-D, 2 × Ethernet [Modbus TCP, EtherCAT\GDNet], 4 × USB
F064966	e49209	Communication peripherals: DVI-D, 2 × Ethernet [Modbus TCP, EtherCAT\GDNet], 4 × USB, 1 × RS485 ,1 × RS232
F064968	e49210	Communication peripherals: DVI-D, 2 × Ethernet [Modbus TCP, EtherCAT\GDNet], 4 × USB, 1 × CAN
F064970	e49211	Communication peripherals: DVI-D, 2 × Ethernet [Modbus TCP, EtherCAT\GDNet], 4 × USB, 1 × RS485 ,1 × RS232, 1 × CAN

The following codes refer to single CPU modules. See the system documentation for the complete system.

Accessories

Code	Model Number	Description
F057777	SD_CARD1GB	SD Card
F057674	CAV_DVI18	1.8 meter DVI-D cable
F057675	CAV_DVI50	5 meter DVI-D cable
F057676	CAV_USB_AB18	1.8 meter USB 2.0 cable, type A - type B connectors
F057677	CAV_USB_AB50	5 meter USB 2.0 cable, type A - type B connectors
F057679	USB_PEN1G	USB 1GB key

CPU MODULE series eCPU400 model e493xx



The eCPU400 series model e493xx CPU module manages pages and the PLC. It installs in the first slot on the left of the rack. It is powered by the back-plane, which connects it to the I/O modules.

The front of the module has a standard DVI-D output and ports for connections to the operator interface, to the Ethernet, and to other devices and buses.

Available with ATOM E660 processor, frequency 1,3 GHz.

Main characteristics:

- Management of PLC and display
- Standard IEC 61131-3 programming: complete support of all languages
- Powered by rack back-plane
- No maintenance: fanless; no moving parts
- High data storage capacity: 2 GB solid state mass memory
- Basic model with DVI-D port, two USB ports and one Ethernet
- Fieldbus options: second Ethernet port for Modbus TCP, GDNNet Master and EtherCAT Master communication; CAN port for CANopen Master communication
- Serial options: one RS485 port and one RS232 port.

Code	According to model (see order code)
Model Number	e493xx (see order code)
Description	CPU module to manage PLC and display. 1,3 GHz Intel Atom E660 processor
Position rack	In the first slot on the left, dedicated fixed position

Technical data

POWER SUPPLY	Internal	via back-plane
	Power Dissipation	15 W max
BACKUP BATTERY	Type	ML2032, rechargeable Li-AI 3 V 65 mAh, non-replaceable
	Life	10 years; 3 months without power supply
CONNECTIONS	Rack	Card-edge
	Video output	Connector: DVI-D Intel integrated 2D/3D graphic interface Resolution: settable via software (800x600 or 1024x768) Max. connection distance: 5 meters
	Ethernet (ETH) port	Number of channels: 2 max (1 optional) Connector: RJ45 Speed: 10 / 100 / 1000 Mbit/s Signals: green connection LED, yellow data LED
	RS-485 port (optional)	Optically isolated Connector: DB9 M Speed: 9,6 kbit/s ... 19,2 kbit/s Termination and polarizations: internal
	USB port	Number of ports: 4 max (2 optional) Connector: type A Standard: USB 2.0 Protection: overload
	CAN port (optional)	Optically isolated Connector: DB9M Speed: 20, 50, 100, 125, 250, 500, 1000 kbit/s, default 500 kbit/s Termination: external
	RS-232 port (optional)	Connector: DB9 M Speed: 1.2 kbit/s ... 115 kbit/s
COMMUNICATION PROTOCOLS	Ethernet	FTP (File Transfer Protocol) Modbus TCP/IP Master/Slave
	CAN	CANopen Master
	Modbus	Modbus RTU Master/Slave
	GDNet	GDNet Master (Real Time Fast Ethernet)
	EtherCAT	EtherCAT Master
CONFIGURATION ELEMENTS	Software procedure access	16-position rotary selector
	PLC management	3-position selector *
DISPLAY ELEMENTS	Diagnostics	LED PW (yellow): power ON LED RN (green): PLC program status LED E1 (red): error bus I/O local LED E2 (red): Watchdog HW status LED E3 (red): Watchdog SW status LED E4 (red): PLC program status
MICROPROCESSOR	Type and frequency	ATOM E660, 1.3 GHz
MEMORY	System	512 MB, DRAM type DDRII
	Mass	2 GB Flash memory
	Mass memory extension	Slot SD Card **
AMBIENT CONDITIONS	Operating temperature	0 ... +50 °C (as per IEC 68-2-14)
	Storage temperature	-20 ... +70 °C (as per IEC 68-2-14)
	Relative humidity	max 95% RH non-condensing (as per IEC 68-2-3)
ASSEMBLY		On rack, with snap hooks
PROTECTION LEVEL		IP20
WEIGHT		0,5 kg
CE STANDARDS	EMC (electromagnetic compatibility)	Conforms to Directive 2004/108/CE EMC Emission: EN 61000-6-4 EMC Immunity: EN 61131-2, EN 61000-4-2, EN 61000-4-3, EN 61000-4-4, EN 61000-4-5, EN 61000-4-6, EN 61000-4-8, EN 61000-4-11
	LV (low voltage)	Conforms to Directive 2006/95/CE Safety LVD: EN 61010-1

* Currently not managed.

** SD Card not included, available as accessory.

Order code

CPU modules series eCPU400 model e493xx, CPU Intel Atom E660 (1.3 GHz), 512 MB RAM, 2 GB Flash memory.

Code	Model Number	Description
F057766	e49300	Communication peripherals: DVI-D, 1 × Ethernet [Modbus TCP], 2 × USB
F057767	e49301	Communication peripherals: DVI-D, 1 × Ethernet [Modbus TCP], 2 × USB, 1 × RS485, 1 × RS232
F057768	e49302	Communication peripherals: DVI-D, 1 × Ethernet [Modbus TCP], 2 × USB, 1 × CAN
F057769	e49303	Communication peripherals: DVI-D, 1 × Ethernet [Modbus TCP], 2 × USB, 1 × RS485, 1 × RS232, 1 × CAN
F057770	e49304	Communication peripherals: DVI-D, 2 × Ethernet [Modbus TCP, GDNet], 4 × USB
F057771	e49305	Communication peripherals: DVI-D, 2 × Ethernet [Modbus TCP, GDNet], 4 × USB, 1 × RS485, 1 × RS232
F057772	e49306	Communication peripherals: DVI-D, 2 × Ethernet [Modbus TCP, GDNet], 4 × USB, 1 × CAN
F057773	e49307	Communication peripherals: DVI-D, 2 × Ethernet [Modbus TCP, GDNet], 4 × USB, 1 × RS485, 1 × RS232, 1 × CAN
F064965	e49308	Communication peripherals: DVI-D, 2 × Ethernet [Modbus TCP, EtherCAT\GDNet], 4 × USB
F064967	e49309	Communication peripherals: DVI-D, 2 × Ethernet [Modbus TCP, EtherCAT\GDNet], 4 × USB, 1 × RS485, 1 × RS232
F064969	e49310	Communication peripherals: DVI-D, 2 × Ethernet [Modbus TCP, EtherCAT\GDNet], 4 × USB, 1 × CAN
F064971	e49311	Communication peripherals: DVI-D, 2 × Ethernet [Modbus TCP, EtherCAT\GDNet], 4 × USB, 1 × RS485, 1 × RS232, 1 × CAN

The following codes refer to single CPU modules. See the system documentation for the complete system.

Accessories

Code	Model Number	Description
F057777	SD_CARD1GB	SD Card
F057674	CAV_DVI18	1.8 meter DVI-D cable
F057675	CAV_DVI50	5 meter DVI-D cable
F057676	CAV_USB_AB18	1.8 meter USB 2.0 cable, type A - type B connectors
F057677	CAV_USB_AB50	5 meter USB 2.0 cable, type A - type B connectors
F057679	USB_PEN1G	USB 1GB key

e410 DIGITAL I/O MODULE series e41x



e410

The e410 module manages 16 digital inputs and 20 digital outputs (24 VDC) with which you can:

- acquire various data from controlled devices and the environment by means of signals and sensors;
- control and adjust devices by means of different types of signals and commands.

Inputs 1, 2 and 3 can be configured as universal counters. The module installs in the rack and is powered by the back-plane, which connects it to the eCPU400 module.

The module, with 20 A of current suppliable simultaneously to the outputs, occupies 2 slots on the rack. The front of the module has 2 24-pin connectors for external connections and LEDs for diagnostics of individual channels.

Main characteristics:

- Digital I/O module with 36 channels: 16 inputs + 20 outputs
- Inputs 1, 2 and 3 can also be configured as universal counters
- Output voltage: 24 VDC
- Powered by rack back-plane
- Double slot module
- Status, power supply, alarm LEDs
- Integrated technology functions: high frequency counters, PWM outputs

Code	F057165
Model Number	e410
Description	36 channel digital I/O module 16 inputs + 20 outputs
Position rack	Free from slot 1 to slot 7, 2 slots employment

Technical data

POWER SUPPLY	Internal	via back-plane
	Power Dissipation	16,7 W max
CONNECTIONS	Rack	Card-edge
	I/O Ports	2 polarized plug-in connectors, male, 24-pin (2 rows of 12 pins) *
DISPLAY ELEMENTS	Diagnostics	16 green input status LEDs (ON/OFF) 20 green output status LEDs (ON/OFF) 1 red alarm LED 4 yellow power supply LEDs
DIGITAL INPUT	Number	16 inputs 1, 2, 3 can also be configured as fast digital inputs
	Type	Current-draw, conforming to types 1, 2, 3 of standard IEC61131-2
	Rated voltage	24 VDC
	Max input voltage	32 VDC
	Max input current	6,5 mA
	Switching threshold	Low level: ≤ 8 VDC High level: ≥ 9 VDC
	Hardware filter	Inputs 1, 2, 3: 50 kHz Inputs 4...16: 100 Hz
	Switching delay	0 \rightarrow 1: 100 μ s 1 \rightarrow 0: 85 μ s
	Protections	Polarity inversion Over-voltage: max 1 kV per 1 ms
	Electrical isolation	Channel - channel: no Channel - CPU bus: 2 kV
FAST DIGITAL INPUT	Max number	3 (first 3 digital inputs)
	Type	Current-draw, conforming to types 1, 2, 3 of standard IEC61131-2
	Rated voltage	24 VDC
	Max input voltage	32 VDC
	Max input current	6,5 mA
	Switching threshold	Low level: ≤ 8 VDC High level: ≥ 9 VDC
	Hardware filter	50 kHz
	Switching delay	0 \rightarrow 1: 100 μ s 1 \rightarrow 0: 85 μ s
	Protections	Polarity inversion Over-voltage: max 1 kV per 1 ms
	Electrical isolation	Channel - channel: no Channel - bus CPU : 2 kV
	Output format position / counter	Type: DINT Resolution: 32 bit (-2 147 483 648 ... 2 147 483 647)
	Output format speed	Type: DINT Resolution: 32 bit (-2 147 483 648 ... 2 147 483 647) LSB: 0,1 impulse/s
	Output format period meter / pulse length meter	Type: DINT Resolution: 32 bit (0 ... 21,4 s) LSB: 10 ns
	Output format frequency meter	Type: DINT Resolution: 32 bit (0 ... 500 kHz) LSB: 0,1 Hz
	Main functions	3 monodirectional incremental encoders [A]; 1 monodirectional incremental encoder + zero notch [A+Z]; 1 bidirectional incremental encoder [AB]; 1 bidirectional incremental encoder + zero notch [AB+Z]; 3 forward count [Counter]

FAST DIGITAL INPUT	Auxiliary functions	Period meter Frequency meter Duty cycle meter Positive/negative pulse meter
DIGITAL OUTPUT	Number	20 Outputs 1 and 2 configurable as ON/OFF (default), PWM or frequency generator
	Composition	One power wire for every 5 outputs
	Type	Current-emission
	Rated voltage	24 VDC \pm 25%
	Max output current	Outputs 1...2: 1 A Outputs 3...20: 2 A Group of 20 outputs: 20 A per module on double slot
	Max switching frequency	100 Hz
	Switching delay	0 \rightarrow 1: 20 μ s 1 \rightarrow 0: 50 μ s
	Protections	Short circuit Overload: $I \geq 2,2$ A (as per IEC 61131), trip time: 500 ms min Overtemperature
Electrical isolation	Channel - channel: no Channel - bus CPU : 2 kV	
PWM / FREQUENCY GENERATOR OUTPUT	Max number	2 (first 2 digital outputs)
	Max output current	Single output: 1 A
	PWM output	Duty cycle: resolution 0,01% Frequency: resolution 0,01 Hz Frequency max: 5 kHz Type: UINT (0...10 000)
	Frequency output	Duty cycle: 50% Frequency: resolution 0,01 Hz Frequency max: 50 kHz Type: DINT (0...5 000 000)
AMBIENT CONDITIONS	Operating temperature	0 ... +50 °C (as per IEC 68-2-14)
	Storage temperature	-20 ... +70 °C (as per IEC 68-2-14)
	Relative humidity	max 95% RH non-condensing (as per IEC 68-2-3)
ASSEMBLY		On rack, with snap hooks
PROTECTION LEVEL		IP20
WEIGHT		0,22 kg
NORME CE	EMC (electromagnetic compatibility)	Conforms to Directive 2004/108/CE EMC Emission: EN 61000-6-4 EMC Immunity: EN 61131-2, EN 61000-4-2, EN 61000-4-3, EN 61000-4-4, EN 61000-4-5, EN 61000-4-6, EN 61000-4-8, EN 61000-4-11
	LV (low voltage)	Conforms to Directive 2006/95/CE Safety LVD: EN 61010-1

* Female connectors not supplied. See accessories for order Model Number

Order code

The following codes refer to single digital I/O modules. See the system documentation for the complete system.

Code	Model Number	Description
F057165	e410	Double slot module with 16 digital inputs and 20 digital outputs. Module diagnostics LED. 24 VDC positive logic inputs, complete with status LED. 24 VDC 2A outputs, complete with status LED, maximum current deliverable simultaneously: 20 A. Two 24-pin connectors (to be ordered separately).

Accessories

Code	Model Number	Description
F057774	eCON24	24-pin female connector, complete with extractors

Me411 DIGITAL I/O MODULE series e41x

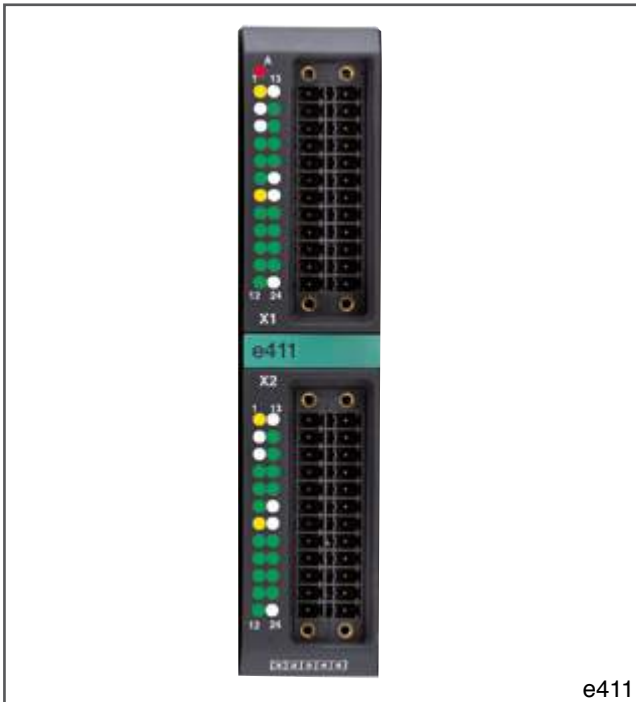

The e411 module manages 16 digital inputs and 16 digital outputs (24 VDC) with which you can:

- acquire various data from controlled devices and the environment by means of signals and sensors;
- control and adjust devices by means of different types of signals and commands.

The module installs in the rack and is powered by the back-plane, which connects it to the eCPU400 module.

The module, with 8 A of current suppliable simultaneously to the outputs, occupies 1 slot on the rack.

The front of the module has 2 24-pin connectors for external connections and LEDs for diagnostics of individual channels.

Main characteristics:

- Digital I/O module with 32 channels: 16 inputs + 16 outputs
- Output voltage: 24 VDC
- Powered by rack back-plane
- Single slot module
- Status, power supply, alarm LEDs.

Code	F065881
Model Number	e411
Description	M32 channel digital I/O module 16 inputs + 16 outputs
Position rack	Free from slot 1 to slot 8, 1 slot employment

Technical data

POWER SUPPLY	Internal	via back-plane
	Power Dissipation	11,3 W max
CONNECTIONS	Rack	Card-edge
	I/O Ports	2 polarized plug-in connectors, male, 24-pin (2 rows of 12 pins) *
DISPLAY ELEMENTS	Diagnostics	16 green input status LEDs (ON/OFF) 16 green output status LEDs (ON/OFF) 1 red alarm LED 4 yellow power supply LEDs
DIGITAL INPUT	Number	16
	Type	Current-draw, conforming to types 1, 2, 3 of standard IEC61131-2
	Rated voltage	24 VDC
	Max input voltage	32 VDC
	Max input current	6,5 mA
	Switching threshold	Low level: ≤ 8 VDC High level: ≥ 9 VDC
	Switching delay	0 \rightarrow 1: 100 μ s 1 \rightarrow 0: 85 μ s
	Filtre Hardware	100 Hz
	Protections	Polarity inversion Over-voltage: max 1 kV per 1 ms
	Electrical isolation	Channel - channel: no Channel - CPU bus: 2 kV
DIGITAL OUTPUT	Number	16
	Composition	One power supply wire for DO1..DO3; DO4..DO8; DO9..DO11; DO12..DO16
	Type	Current-emission
	Rated voltage	24 VDC $\pm 25\%$
	Max output current	Group of 16 outputs: 8 A
	Max switching frequency	100 Hz
	Switching delay	0 \rightarrow 1: 20 μ s 1 \rightarrow 0: 50 μ s
	Protections	Short circuit Overload: $I \geq 2,2$ A (as per IEC 61131), trip time: 500 ms min Overtemperature
Electrical isolation	Channel - channel: no Channel - bus CPU : 2 kV	
AMBIENT CONDITIONS	Operating temperature	0 ... +50 °C (as per IEC 68-2-14)
	Storage temperature	-20 ... +70 °C (as per IEC 68-2-14)
	Relative humidity	max 95% RH non-condensing (as per IEC 68-2-3)
ASSEMBLY		On rack, with snap hooks
PROTECTION LEVEL		IP20
WEIGHT		0,14 kg
NORME CE	EMC (electromagnetic compatibility)	Conforms to Directive 2004/108/CE EMC Emission: EN 61000-6-4 EMC Immunity: EN 61131-2, EN 61000-4-2, EN 61000-4-3, EN 61000-4-4, EN 61000-4-5, EN 61000-4-6, EN 61000-4-8, EN 61000-4-11
	LV (low voltage)	Conforms to Directive 2006/95/CE Safety LVD: EN 61010-1

* Female connectors not supplied. See accessories for order Model Number.

Order code

The following codes refer to single digital I/O modules. See the system documentation for the complete system.

Code	Model Number	Description
F065881	e411	Double slot module with 16 digital inputs and 16 digital outputs. Module diagnostics LED. 24 VDC positive logic inputs, complete with status LED. 24 VDC 2A outputs, complete with status LED, maximum current deliverable simultaneously: 8 A. Two 24-pin connectors (to be ordered separately).

Accessories

Code	Model Number	Description
F057774	eCON24	24-pin female connector, complete with extractors

e430 FUNCTIONAL I/O MODULE series e43x

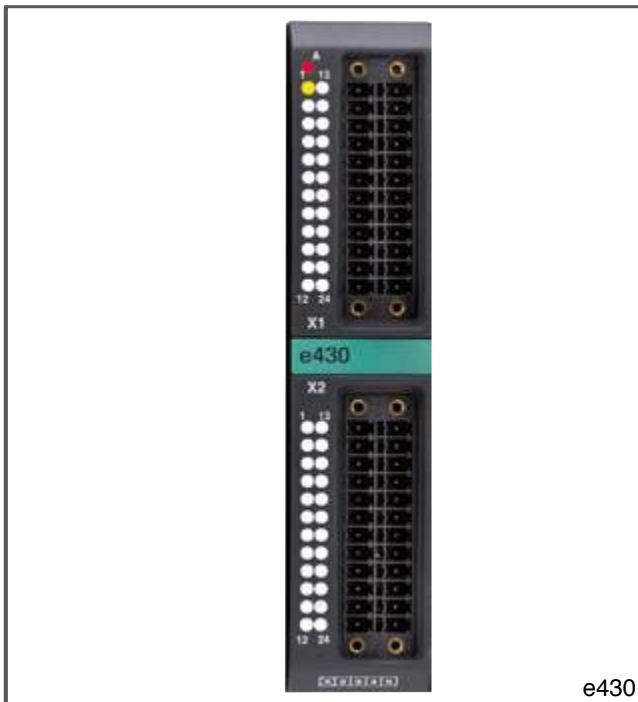

The e430 module manages 6 configurable analog inputs, 4 ± 10 VDC analog outputs and 8 thermocouple inputs with which you can:

- acquire various data from controlled devices and the environment by means of signals and sensors;
- control and adjust devices by means of different types of signals and commands.

The module installs in the rack and is powered by the back-plane, which connects it to the eCPU400 module.

The front of the module has 2 24-pin connectors for external connections and LEDs for diagnostics of module status.

Main characteristics:

- Functional I/O module with 18 channels: 6 analog inputs + 4 analog outputs + 8 temperature inputs
- Powered by rack back-plane
- Single-slot module
- Status LED
- Integrated technology functions: temperature output values in tenth of degree centigrade, comparison of fast analog input with preprogrammed threshold and fast switching of assigned analog output.

Code	F057166
Model Number	e430
Description	18 channel digital I/O module 6 analog inputs + 4 analog outputs + 8 temperature inputs
Position rack	Free from slot 1 to slot 8, 1 slot employment

Technical data

POWER SUPPLY	Internal	via backplane
	Power Dissipation	3 W max
CONNECTIONS	Rack	Card-edge
	I/O Ports	2 polarized plug-in connectors, male, 24 pin (2 rows of 12 pins) *
DISPLAY ELEMENTS	Diagnostic	Red alarm LED Yellow LED for power potentiometer
ANALOG INPUT	Number	6, configurable as single-ended voltage 0...10 V, single ended voltage ± 10 V, potentiometer or current 0...20mA
ANALOG INPUT IN VOLTAGE 0...10 V	Max number	6
	Type	Single-ended voltage 0...10 V
	Input filter	Low-pass, 3 rd order Cut-off frequency: 100 Hz, 1 kHz, 10 kHz selectable via software
	Input impedance	> 1 M Ω
	Sampling time (for all channels)	< 250 μ s
	Output format	Type: UINT Resolution: 14 bit (0 ... 16384) LSB: 0,61 mV
	Max error @ 25 °C	0,2% full scale
	Protections	Over-voltage: max 1 kV for 1 ms
	Electrical isolation	Channel - channel: no Channel - bus CPU: 2 kV
ANALOG INPUT IN VOLTAGE ± 10 V	Max number	6
	Type	Single-ended voltage ± 10 V
	Input filter	Low-pass, 3 rd order Cut-off frequency: 100 Hz, 1 kHz, 10 kHz selectable via software
	Input impedance	> 1 M Ω
	Sampling time (for all channels)	< 250 μ s
	Output format	Type: INT Resolution: 15 bit (-16384 ... +16384) LSB: 0,61 mV
	Max error @ 25°C	0,2% full scale
	Protections	Overvoltage: max 1 kV per 1 ms
	Electrical isolation	Channel - channel: no Channel - bus CPU: 2 kV
ANALOG INPUT IN CURRENT 0...20 mA	Max number	6
	Type	Current 0...20 mA
	Input filter	Low-pass, 3 rd order Cut-off frequency: 100 Hz, 1 kHz, 10 kHz selectable via software
	Input impedance	100 Ω , 0,1%
	Sampling time (for all channels)	< 250 μ s
	Output format	Type: UINT Resolution: 14 bit (0 ... 16384) LSB: 1,22 mA
	Max error @ 25 °C	0,3% full scale
	Protections	Overvoltage: max 1 kV per 1 ms
	Electrical isolation	Channel - channel: no Channel - bus CPU: 2 kV

ANALOG INPUT POTENTIOMETER	Max number	6
	Type	Potentiometer 2 k Ω min
	Transducer power supply	On card, 10 V - 100 mA max
	Input filter	Low-pass, 3 rd order Cut-off frequency: 100 Hz, 1 kHz, 10 kHz selectable via software
	Input impedance	> 1 M Ω
	Sampling time (for all channels)	< 250 μ s
	Output format	Type: UINT Resolution: 14 bit (0 ... 16384) LSB: 0,61 mV
	Max Error @ 25 °C	0,2% full scale
	Protections	Overvoltage: max 1 kV per 1 ms
	Electrical isolation	Channel - channel: no Channel - bus CPU: 2 kV
THERMOCOUPLE INPUT	Number	8
	Type	Thermocouple J, K, S, N, T, E, B, R, L Differential voltage 0...60 mV
	Connection type	2 wires, for isolated and non-isolated probes
	Bandwidth	1 Hz
	Input impedance	> 1 M Ω
	Sampling time (for all channels)	< 12 ms
	Resolution	0,1 °C
	Max error @ 25 °C	0,5% full scale
	Thermocouple use interval (scale)	J: 0 ... 1000 °C K: 0 ... 1300 °C R: 0 ... 1750 °C S: 0 ... 1750 °C T: -200 ... 400 °C E: -100 ... 750 °C B: 0 ... 1820 °C (max error 0.5% f.s. for Temp. >300°C) L: 0 ... 800 °C N: 0 ... 1300 °C
	Temperature compensation	Internal
ANALOG OUTPUT	Number	4
	Type	Single-ended voltage \pm 10 V
	Max output current	20 mA
	Refresh time	1 ms
	Settling time	< 200 μ s
	Output format	Type: INT Resolution: 14 bit (-8192 ... +8192) LSB: 1,22 mV
	Error max @ 25 °C	0,2% full scale
	Protections	Short circuit Overload: I \geq 25 mA Max overvoltage 1 kV per 1 ms
	Electrical isolation	Channel - channel: no Channel - bus CPU: 2 kV
AMBIENT CONDITIONS	Operating temperature	0 ... +50 °C (as per IEC 68-2-14)
	Storage temperature	-20 ... +70 °C (as per IEC 68-2-14)
	Relative humidity	max 95% RH non-condensing (as per IEC 68-2-3)
ASSEMBLY		On rack, with snap hooks
PROTECTION LEVEL		IP20
WEIGHT		0,15 kg

CE STANDARDS	EMC (electromagnetic compatibility)	Conforms to Directive 2004/108/CE EMC Emission: EN 61000-6-4 EMC Immunity: EN 61131-2, EN 61000-4-2, EN 61000-4-3, EN 61000-4-4, EN 61000-4-5, EN 61000-4-6, EN 61000-4-8, EN 61000-4-11
	LV (low voltage)	Conforms to Directive 2006/95/CE Safety LVD: EN 61010-1

* C Female connectors not supplied. See accessories for order Model Number

Order code

The codes below refer to the individual I / O modules. For the complete system, refer to the system documentation.

Code	Model Number	Description
F057166	e430	Single slot module with 6 analog inputs, 4 analog outputs and 8 temperature inputs. Module diagnostics LED. Analog inputs configurable as: - voltage 0...10 VDC, voltage \pm 10 VDC, potentiometer - current 0...20 mA Voltage type analog outputs \pm 10 VDC, 20 mA max. Thermocouple type temperature inputs (J, K, S, N, T, E, B, R, L)

Accessories

Code	Model Number	Description
F057774	eCON24	24-pin female connector

FUNCTIONAL I/O MODULE serie e43x

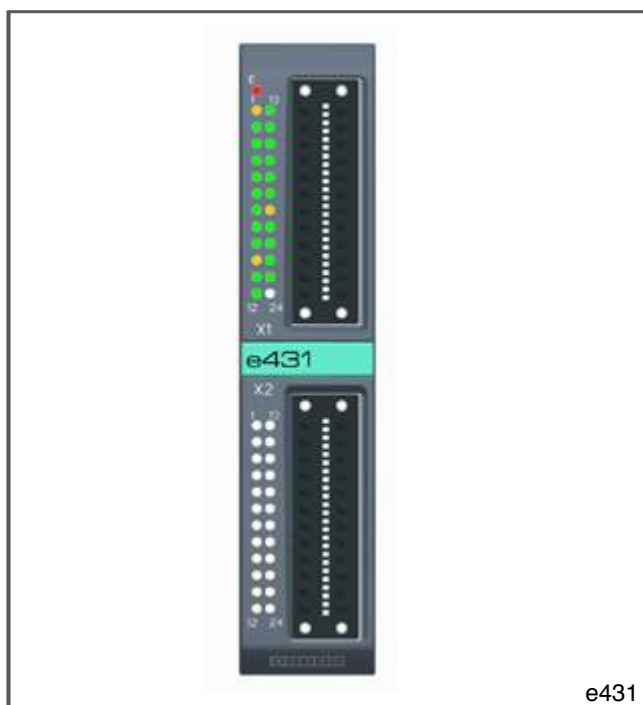

e431

The e431 module manages 20 digital outputs 24 VDC and 12 thermocouple inputs with which you can:

- acquire various data from controlled devices and the environment by means of sensors;
- control and adjust devices by means of different types of signals and commands.

The module installs in the rack and is powered by the back-plane, which connects it to the eCPU400 module.

The front of the module has 2 24-pin connectors for external connections and LEDs for diagnostics of module status and digital outputs.

Main characteristics:

- Functional I/O module with 32 channels: 20 digital outputs + 12 temperature inputs
- Powered by rack back-plane
- Single-slot module
- Status LED
- Integrated technology functions: temperature output values in tenth of degree centigrade, internal compensation of cold junction

Code	F071367
Model Number	e431
Description	32 channel digital I/O module 20 digital outputs + 12 temperature inputs
Position rack	Free from slot 1 to slot 8, 1 slot employment

Technical data

POWER SUPPLY	Internal	via backplane
	Power dissipation	8 W max
CONNECTIONS	Rack	Card-edge
	I/O Ports	2 polarized plug-in connectors, male, 24 pin (2 rows of 12 pins) *
DISPLAY ELEMENTS	Diagnostic	20 green LED Output status 1 Alarm red LED 3 Yellow LEDs Power
DIGITAL OUTPUT	Number	20
	Composition	2 Groups of 8 outputs and 1 group of 4 outputs
	Type	current-emission
	Rated voltage	24 VDC \pm 25%
	Max output current	Single output : 0,5 A Group of 20 outputs: 10 A
	Max switching frequency	100 Hz
	Switching delay	0 \rightarrow 1: 15 μ s 1 \rightarrow 0: 40 μ s
	Protections	Short circuit Overload: $I \geq 0,7$ A (as per IEC 61131), trip time:500 ms min Overtemperature
	Electrical isolation	Channel - channel: no Channel - bus CPU: 2 kV
THERMOCOUPLE INPUT	Number	12
	Type	Thermocouple J, K, S, N, T, E, B, R, L Differential voltage 0...60 mV
	Connection type	2 wires, for isolated and non-isolated probes
	Bandwidth	1 Hz
	Input impedance	> 1 M Ω
	Sampling time (for all channels)	< 100 ms
	Resolution	0,1 $^{\circ}$ C
	Max error @ 25 $^{\circ}$ C	0,5% full scale
	Thermocouple use interval (scale)	J: 0 ... 1000 $^{\circ}$ C K: 0 ... 1300 $^{\circ}$ C R: 0 ... 1750 $^{\circ}$ C S: 0 ... 1750 $^{\circ}$ C T: -200 ... 400 $^{\circ}$ C E: -100 ... 750 $^{\circ}$ C B: 0 ... 1820 $^{\circ}$ C (Err. max 0.5% f.s. for Temp. >300 $^{\circ}$ C) L: 0 ... 800 $^{\circ}$ C N: 0 ... 1300 $^{\circ}$ C
	Temperature compensation	Internal
AMBIENT CONDITIONS	Operating temperature	0 ... +50 $^{\circ}$ C (as per IEC 68-2-14)
	Storage temperature	-20 ... +70 $^{\circ}$ C (as per IEC 68-2-14)
	Relative humidity	max 95% RH non-condensing (as per IEC 68-2-3)
ASSEMBLY		On rack, with snap hooks
PROTECTION LEVEL		IP20
WEIGHT		0,13 kg

CE STANDARDS	EMC (electromagnetic compatibility)	Conforms to Directive 2004/108/CE EMC Emission: EN 61000-6-4 EMC Immunity: EN 61131-2, EN 61000-4-2, EN 61000-4-3, EN61000-4-4, EN 61000-4-5, EN 61000-4-6, EN 61000-4-8, EN 61000-4-11
	LV (low voltage)	Conforms to Directive 2006/95/CE Safety LVD: EN 61010-1
* Female connectors not supplied. See accessories for order Model Number.		

Order codes

The codes below refer to the individual I / O modules.
For the complete system, refer to the system documentation.

Code	Model Number	Description
F071367	e431	Single slot module with 20 digital outputs and 12 temperature inputs. Module diagnostics LED. Digital outputs 24 VDC 0.5 A, complete with status LEDs, maximum current simultaneously 10A. Thermocouple type temperature inputs (J, K, S, N, T, E, B, R, L). Two 24-pin connectors to be ordered separately.

Accessories

Code	Model Number	Description
F057774	eCON24	24-pin female connector

ASSEMBLY AND INSTALLATION

Assembly Operator Panel

Hole dimensions

For correct installation, observe the dimensions of the templates shown in the illustration.

The dotted line shows the maximum size of the front panel

The panel eGT-I provides also two through holes, whose sizes and positions with respect to the main hole are shown in detail in Figure 15.



Attention: the panel on which the Integrated Controller and Operator Panel is mounted has to have the following characteristics:

- be sufficiently stiff and strong so that it does not bend during use;
- a thickness of 1 to 4 mm for the 104" ePanel and 1 to 6 mm for other operator panels so that the device can be fastened with the supplied clamps.

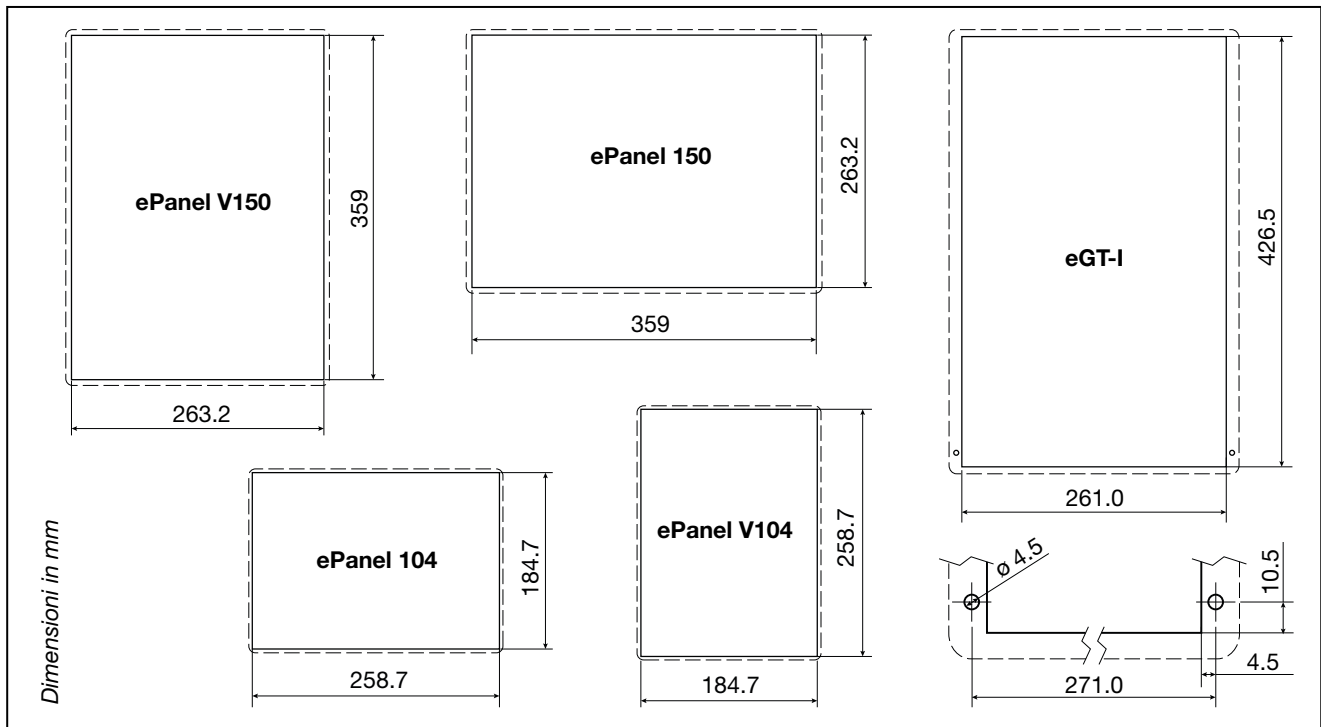

Figure 15 - Panel hole dimensions

Protection against infiltrations of water

The Operator Panel offers, first of all, a degree of protection of IP65 (models ePanel) or IP54 (eGT-I).

It is therefore possible to install the device in particularly dusty environments or areas subject to splashes of water without problems:

- the compartment in which the device is housed also has to be dust and waterproof;
- the panel on which the device is installed must be perfectly smooth and flat on the front;
- the hole in the panel must scrupulously respect the dimensions indicated;
- the device has to be fastened tightly to the panel, to allow the gasket fitted at the back to ensure water tightness.

Vibrations

The Operator Panel can support vibrations:

- from 5 to 9 Hz: sinusoidal 3.5 mm constant;
- from 9 to 150 Hz: sinusoidal with acceleration equal to 1 G

Should the device be mounted on a support that exceeds these limits it is necessary to envisage a system for the suspension and mitigation of the vibrations.

Minimum spaces for ventilation

The temperature of the compartment that houses the Integrated Controller and Operator Panel must not exceed 55°C.

Figure 6 and 8 free spaces for ventilation shows the minimum free distances recommended in the installation of the device in a closed compartment.

Positioning

The Operator Panel has to be positioned in order to guarantee the following conditions:

- the screen must not be directly lit by the sun or particularly bright light sources.
- If necessary, screen direct rays, using an antiglare shutter for example;
- there must be no sudden temperature changes;
- there must be a low explosion risk: it can be connected to elements that operate in environments with a hazardous atmosphere (flammable or explosive) only through appropriate and suitable types of interface, compliant to the safety standards in force;
- low presence of magnetic fields.

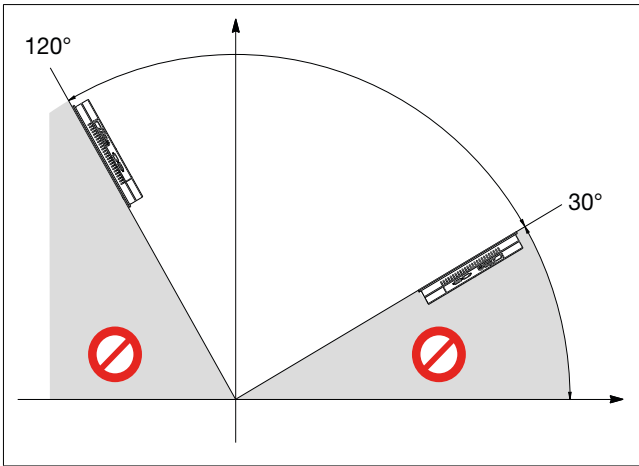

Figure 16 - Admitted angulation

The angulation of the controller must be between 30° and 120°, as shown in Figure 16.

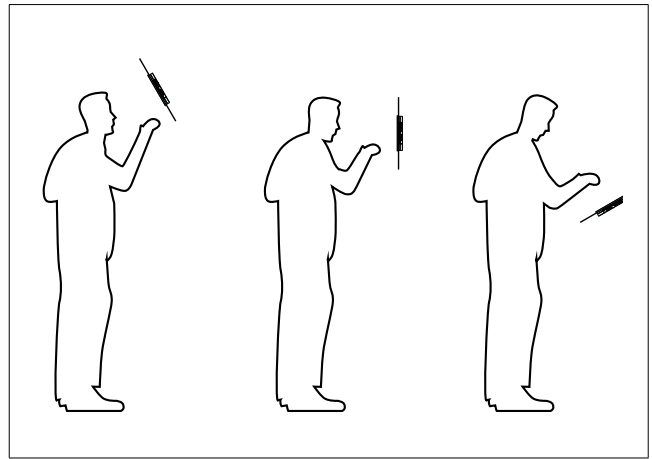

Figure 17 - Position and angulation

The angulation to choose also depends on the position of the controller compared to the operator, as shown in Figure 17.

Fastening to the panel

Fit the Operator in the panel, connect the 4/6 terminals supplied to the device and tighten the screw until the device is fastened tightly to the panel.

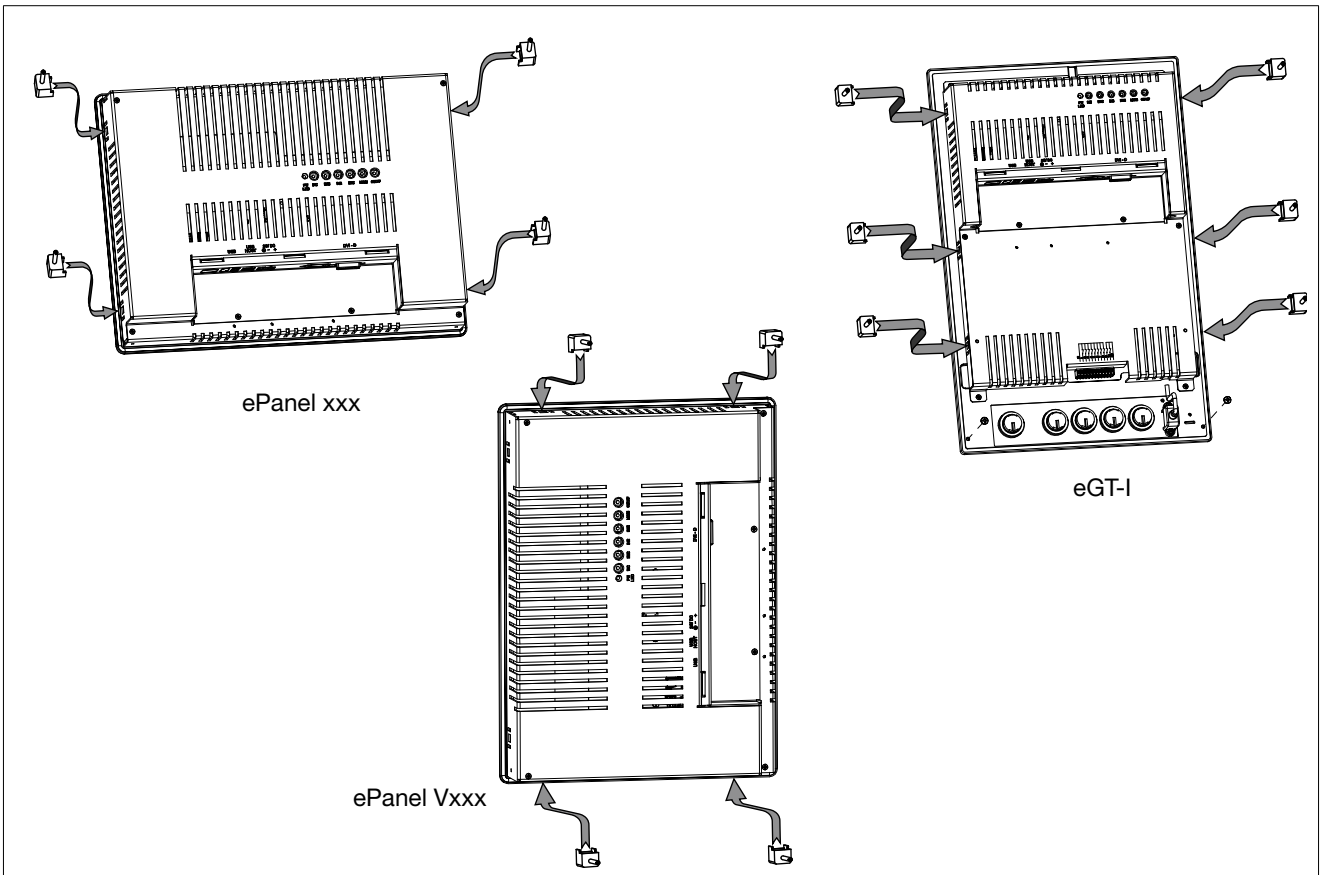
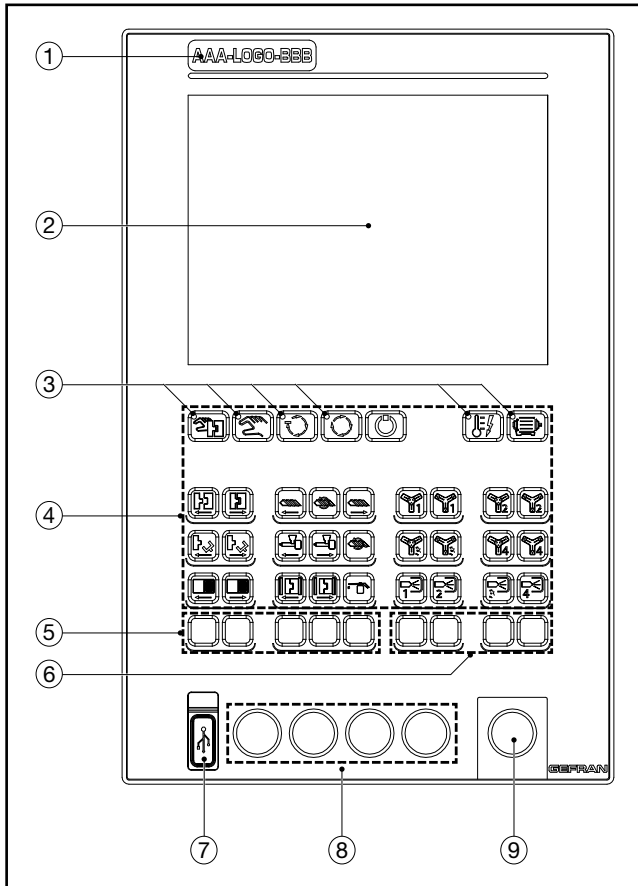

Figure 18 - Positions available for fastening terminals

eGT-I 104-43 Faceplate



1	Customizable logo pocket
2	10.4" Display
3	Machine status LED (4 blue + 2 red)
4	Controls (34)
5	Configurable keys (5)
6	Configurable keys (4)
7	USB KEY
8	Holes for electromechanical keys (4, ø 22 mm)
9	Hole for mushroom emergency button

Figure 19 - Layout of eGT-I controls and signals

Operator Panel Connections

Inputs, ports and signals

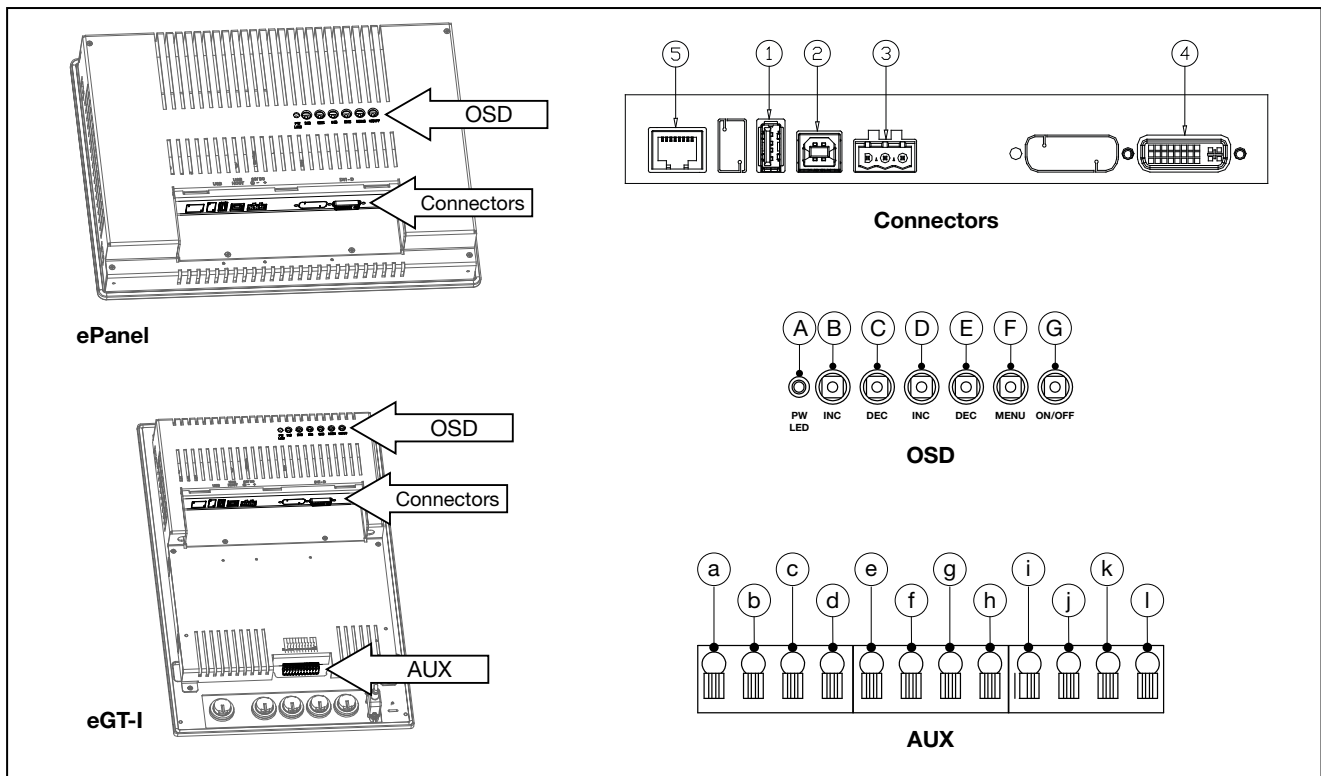

Figure 20 - Position of ePanel and eGT-I connectors

No	Description	Connector / indicator	Notes
1	Host USB port	Type A USB	PEN KEY / USB Keypad
2	Device USB port	Type B USB	ePCLogic400
3	24 VDC \pm 25% power supply input	Removable polarized terminal block	
4	DVI-D input		
5	Key & Led Input (Only for ePanel)	RJ-45	For GEFTRAN Keypad
A	OSD: Power LED	LED	ON: green Stand-by: yellow
B	OSD: Increase / Automatic color	Key	
C	OSD: Decrease / Autocalibration	Key	
D	OSD	Key	DO NOT USE
E	OSD	Key	DO NOT USE
F	OSD: Menu / Enter	Key	
G	OSD: Power	Key	
a	AUX 1...8 common contacts	Spring-loaded terminal	
b	AUX 1 contact	Spring-loaded terminal	
c	AUX 2 contact	Spring-loaded terminal	
d	AUX 3 contact	Spring-loaded terminal	
e	AUX 4 contact	Spring-loaded terminal	
f	AUX 5 contact	Spring-loaded terminal	
g	AUX 6 contact	Spring-loaded terminal	
h	AUX 7 contact	Spring-loaded terminal	
i	AUX 8 contact	Spring-loaded terminal	
j	AUX 9 contact	Spring-loaded terminal	
k	AUX 10 contact	Spring-loaded terminal	
l	AUX 9..0.10 common contacts	Spring-loaded terminal	

Power

The operator ePanel or eGT-I must be connected to a 24 Vdc power supply unit.

The same 24 Vdc power supply can feed several devices controller ePCLoGic400.

Make sure that the current issued by the power supply is higher than the total maximum current absorbed by all the devices connected.

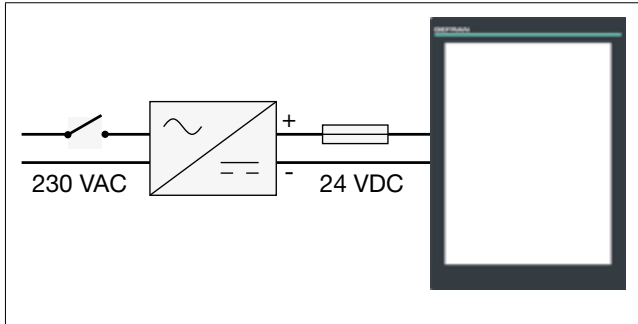

Figure 21 - ePanel power

Considering that the operator ePanel has no switch, it is necessary to install one before it, with a protective fuse.

The switch has to be positioned in the immediate vicinity of the device and be easy for the operator to reach.

For the 24 Vdc power supply, use a separate line from that used for electromechanical power devices such as relays, contactors, solenoids, etc.

If there are considerable changes in the mains voltage, use a voltage stabiliser.

Near to high frequency generators or arc welders, use adequate grid filters.

Connect the power cables to the power connector. Fit the ferrite, supplied with the product, as close as possible to the device to limit the susceptibility of the device to electromagnetic disturbance (Figure 22).

The 24 Vdc power cables must follow a separate route from the power cables of the system or the machine.

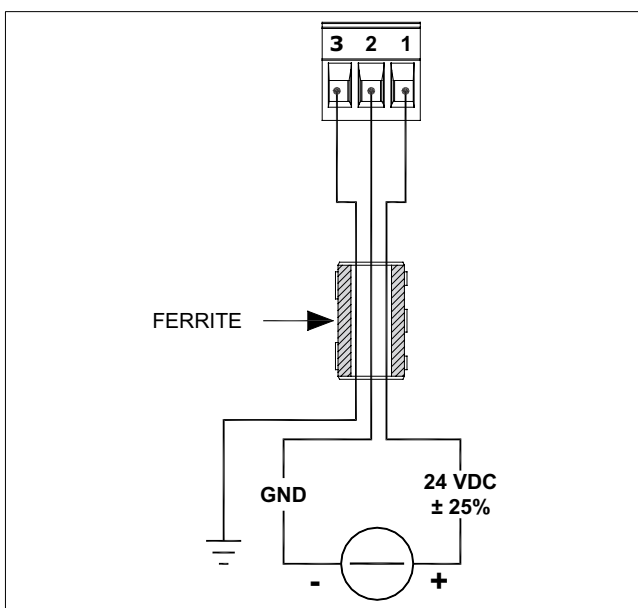

Figure 22 - ePanel or eGT-I power connection



Attention: make sure that the earth connection is efficient. A non-existent or inefficient earth connection can make the operation of the device unstable, due to excessive environmental disturbance.

In particular, check that:

- the voltage between ground and earth is $< 1 \text{ V}$;
- the ohm resistance is $< 6 \Omega$.

USB

There are 2 USB ports:

- 1 port with Type A connector to connect a PEN KEY and a Gefran keyboard
- 1 Type B HOST port to connect the ePCLoGic400 controller

The ports support the USB 2.0 standard, with speed up to 480 Mbit/s.

The Type A ports can deliver 500 mA current at 5 VDC to power connected devices.

The USB cable can have a maximum length of 5 meters. Printers cannot be connected

DVI-D Input

The ePCLoGic400 controller's DVI-D output is connected to this input with a standard DVI-D cable.

The DVI-D cable can have a maximum length of 5 meters.

OSD Keypad

The OSD keypad on the rear of the panel lets you change the display settings (brightness, contrast, etc.)

- To adjust the display, access the functions by pressing the MENU key and follow the instructions on the screen.
- Use the *Increase* and *Decrease* keys to navigate the menus on the display.
- Use the *Increase* and *Decrease* keys to change the values.
- Press *Enter* to select a menu or to confirm the set value.

Auxiliary contacts (eGT-I only)

The eGT-I panel has 10 auxiliary contacts, identified as AUX1...10, on the rear of the panel.

Keys, buttons, etc. can be connected to the contacts. These contacts do not conform to IEC 611131-2 standard.



Warning: the contact must be voltage-free.

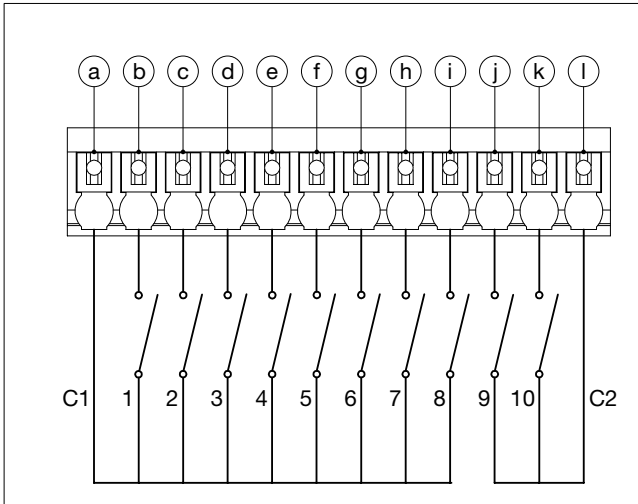

Figure 23 - Layout of eGT-I panel auxiliary contacts

Inserting labels (eGT-I only)

The eGT-I panel and some of its keys can be customized with white plasticized labels

The labels are supplied on a size A4 sheet and include:

- 3 single labels to customize the panel logo [A],
- 3 strips with 4 keys [B],
- 3 strips with 5 keys [C],

The labels can be printed with an ink-jet or laser printer..

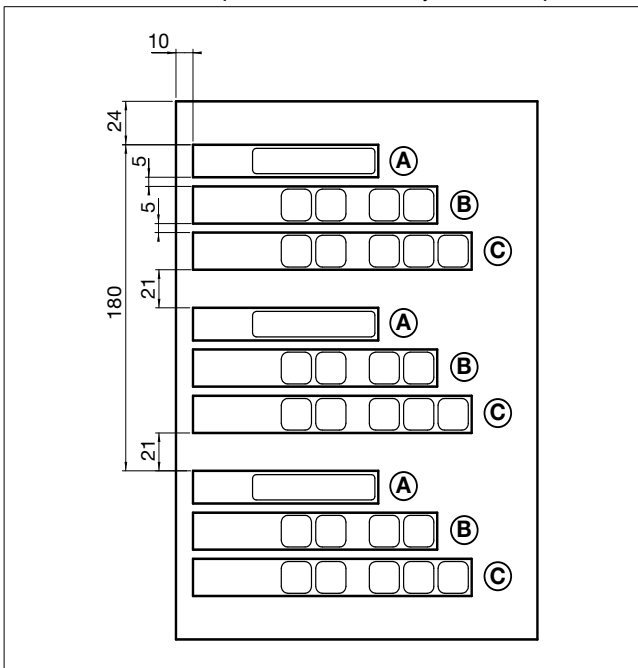

Figure 24 - Dimensions of label sheet

The labels are inserted in the rear slits on the panel

The labels are removable.

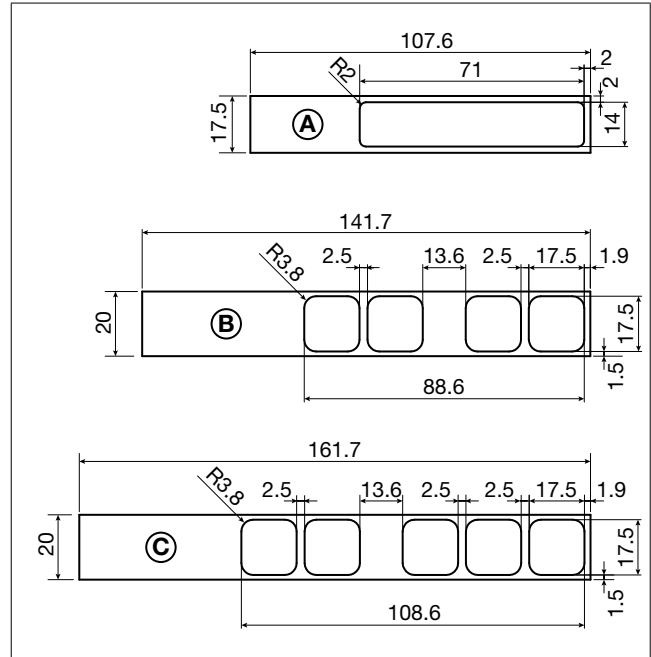

Figure 25 - Dimensions of eGT-I labels

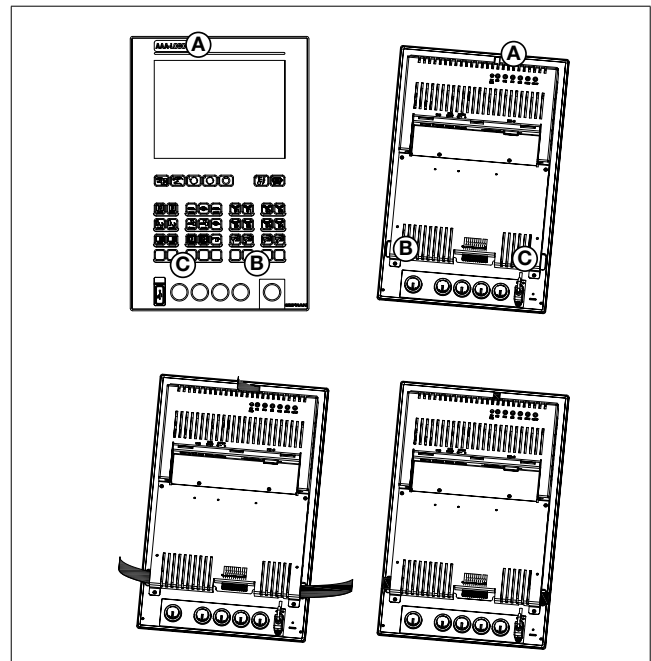

Figure 26 - Inserting eGT-I labels

Mounting the eKM32-104 keyboard

Drilling dimensions

For correct installation, respect the dimensions shown in the figure.

The solid line shows the hole for installation and the broken line shows the maximum size of the front keyboard.



Attention: The support on which the keyboard is mounted must:

- be sufficiently rigid and robust to support the device without bending during use.
- be from 1 to 12 mm thick to allow the device to be fastened with the supplied brackets.

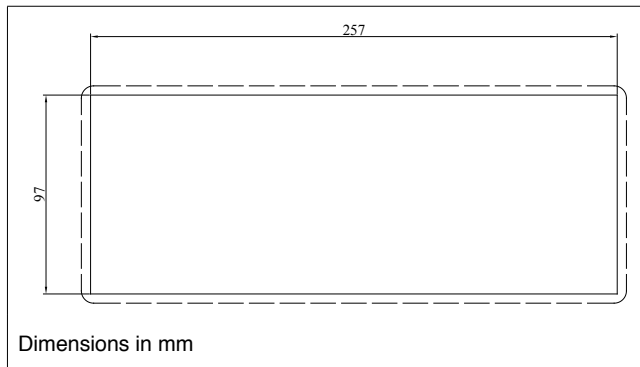

Figure 27 - Hole dimensions for keyboard

Protection against water infiltration

The front of the eKM32-104 keyboard has an IP65 protection index, so the device can be installed without problems in rooms that are very dusty or subject to splashing water provided:

- the housing in which the device is inserted is dust-tight and watertight.
- the support on which the device is installed is perfectly smooth and without undulations on the front.
- the hole on the support scrupulously respects the specified drilling dimensions.
- the device is fully tightened to the support to ensure that the gasket inserted between the device and the panel is watertight

Vibrations

The operator keyboard can support vibrations:

- From 5 to 9 Hz; sine constant 3.5 mm.
- From 10 to 150 Hz: sine with acceleration of 1G.

If the device is mounted on a support that exceeds these limits, it is advisable to provide a suspension system to reduce vibrations

Minimum space for ventilation

The temperature in the housing containing the keyboard must NEVER exceed 55°C

Positioning

The keyboard must be positioned in order to ensure the following conditions:

- The surface of the keys must not be exposed to direct sunlight or to very strong light sources.
- There must be no sudden temperature changes.
- There must be a low risk of explosion: can be connected to elements that work in a potentially inflammable or explosive atmosphere only by means of appropriate interfaces that conform to safety regulations in force in the country of installation.
- Low presence of magnetic fields

Fastening to support

Insert the keyboard into the support, attach the 2 clamps (supplied) and tighten the screws to fasten the device firmly to the support.

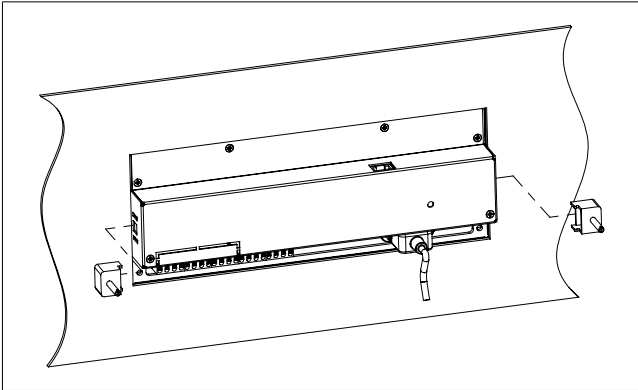

Figure 28 – Installation and fastening blocks

The blocks must be tightened so that the gasket correctly adheres to the panel in order to ensure protection against infiltration of liquids.

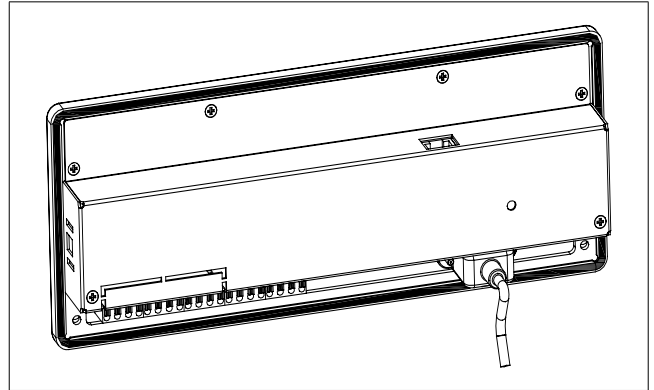

Figure 29 - Gasket

eKM32-104 faceplate

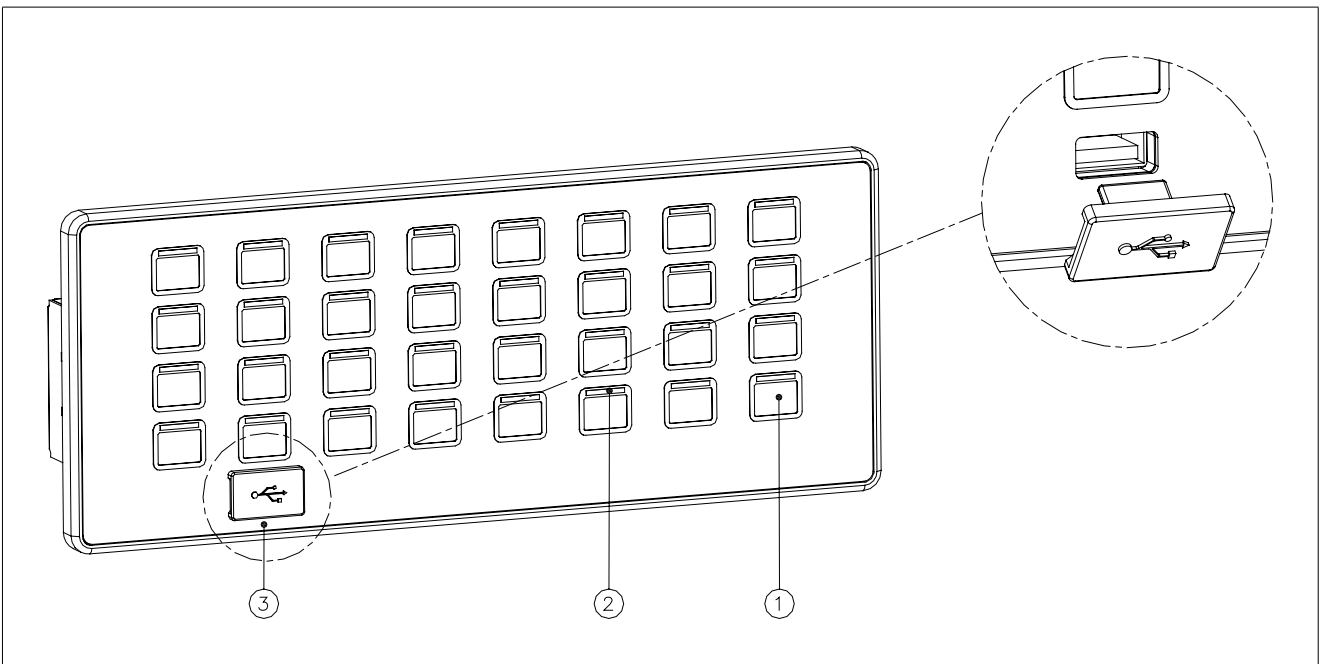

Figure 30 - Faceplate

1	Keys with customization labels
2	LEDS
3	USB type A port with cover

eKM32-104 connections

Inputs, ports and signals

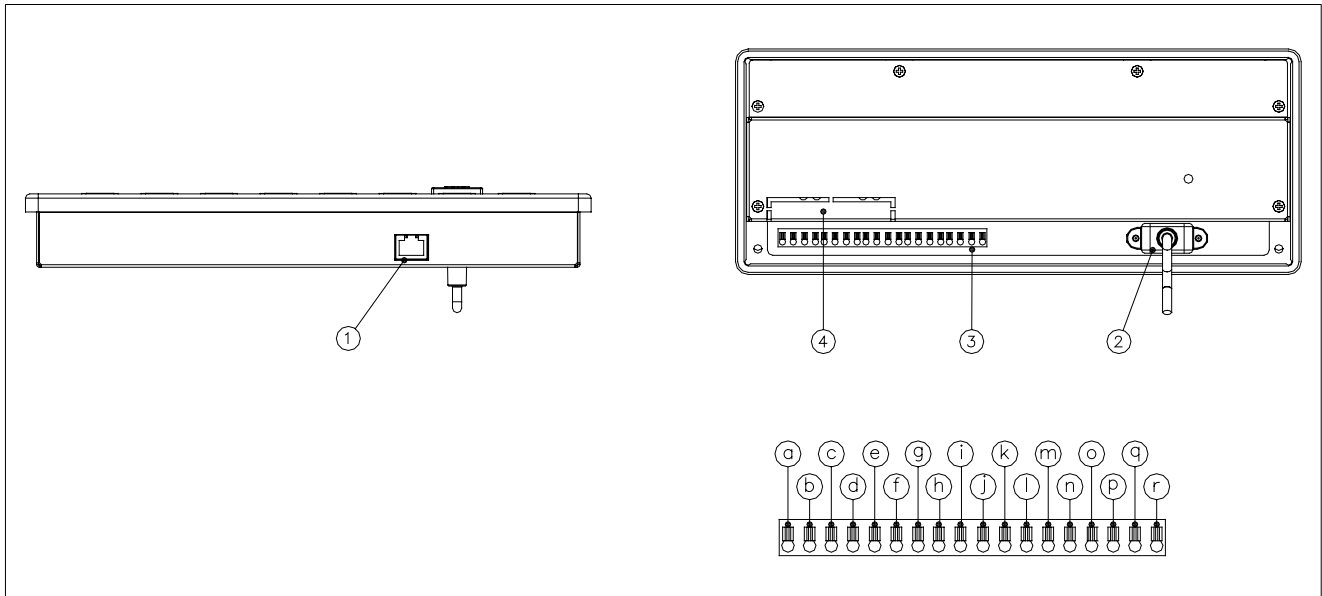

Figure 31 - Ports and signals

N.	Description	Connector / indicator	Notes
1	Power supply and signal	RJ-45	
2	USB extension cable (length: 1 m)	USB Type A	
3	Auxiliary contacts (AUX)	Spring-loaded terminal	
a	AUX 1...8 common contacts		
b	AUX 1 contact		
c	AUX 2 contact		
d	AUX contact 3		
e	AUX contact 4		
f	AUX contact 5		
g	AUX contact 6		
h	AUX 7 contact		
i	AUX 8 contact		
j	AUX 9...16 common contacts		
k	AUX 9 contact		
l	AUX 10 contact		
m	AUX 11 contact		
n	AUX 12 contact		
o	AUX 13 contact		
p	AUX 14 contact		
q	AUX 15 contact		
r	AUX 16 contact		
4	Provision for future developments.		NOT USED

Power supply and communication

The keyboard is powered and communication with the Operator Panel is provided by the Ethernet CAT 5e cable included and connected to the RJ45 connector.

ATTENTION

The keyboard can be connected ONLY to Operator Panels (see panel documentation). Any other use may damage the products.

Auxiliary contacts

The eKM32-104 keyboard has 16 auxiliary contacts, identified as AUX1..AUX16, located on the rear of the panel.

Keys, buttons, etc. can be connected to the contacts. These contacts do not conform to IEC61131-2 standard.



Attention: the contact must be voltage-free.

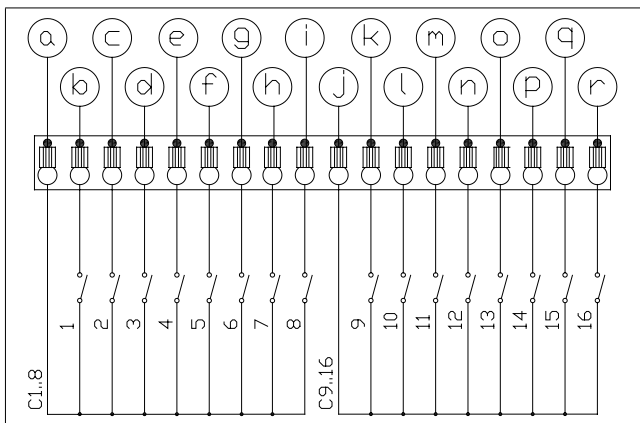

Figure 32 - Diagram of eKM32-104 auxiliary contacts

Customizing the keys

All of the keys on the eKM32-104 keyboard can be customized with transparent plastic labels.

Two customizing sets are available:

- Neutral labels

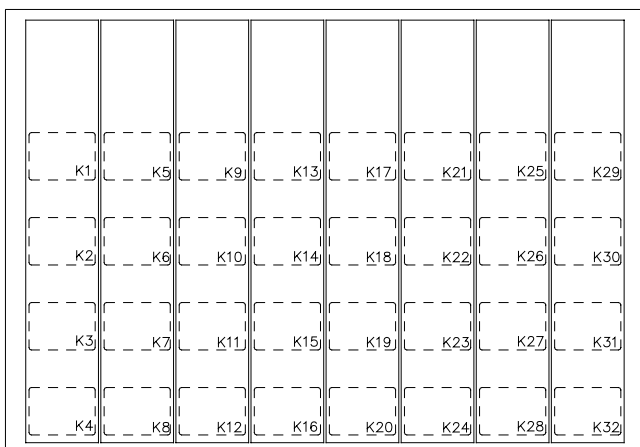

Figure 33 - Set of neutral labels

- Injection labels (see Figure 34)

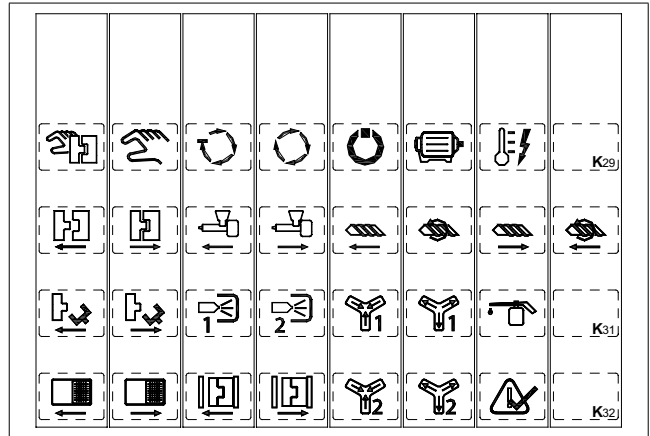

Figure 34 - Set of injection labels

You can make your own custom symbols for the keyboard by printing them on transparent film (recommended thickness 100 um) with an ink-jet or laser printer. example: sheet of XEROX Premium Transparencies code 003R98205.

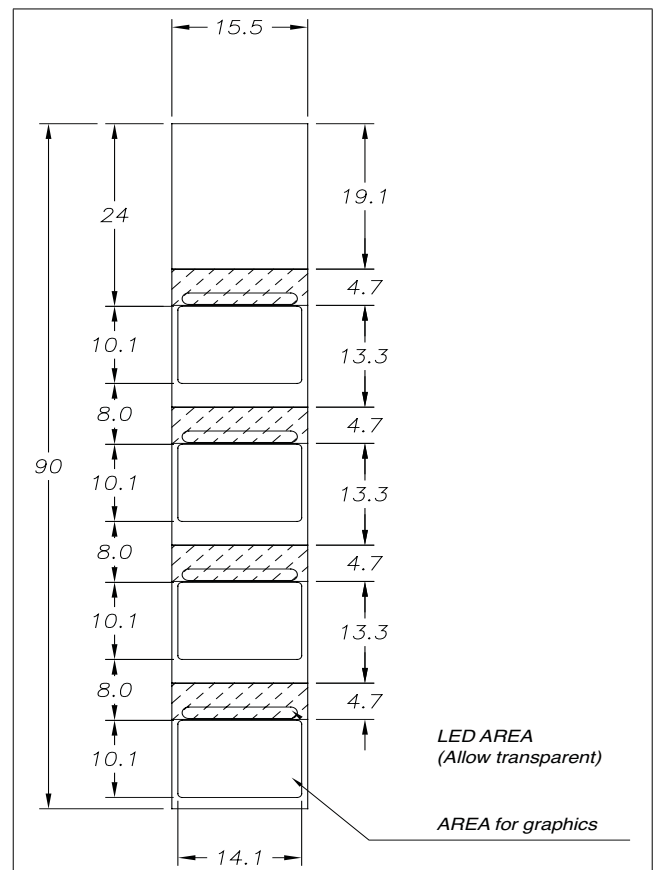

Figure 35 - Label dimensions

Inserting labels

Insert the custom key labels as shown in Figure 36:

- Remove the cover by unscrewing the 6 fixing screws.
- Remove any previously inserted labels.
- Insert the new labels. Insert the label from the top down. The arrow indicates the printed side of the label.
- Check that the symbols are aligned with the window.
- Reposition the cover and screw down the 6 screws.

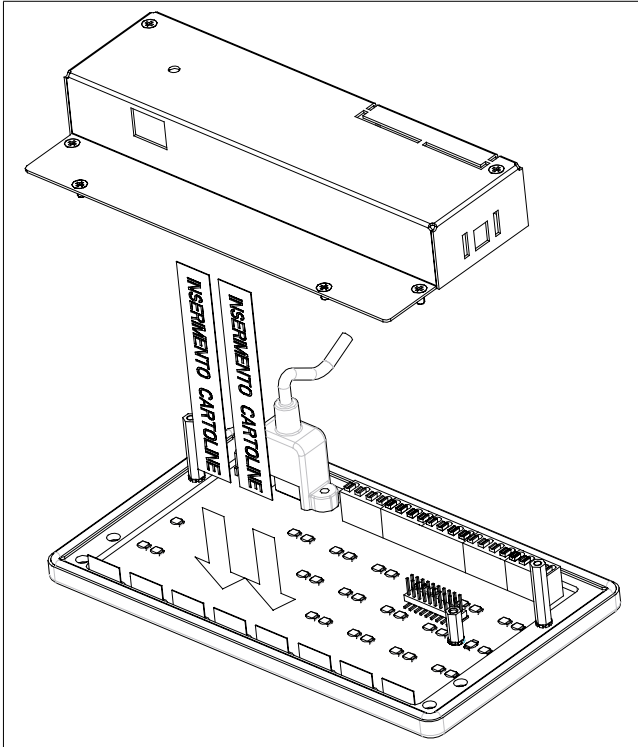

Figure 36 - Inserting labels

Mounting the ePCLoGic400 controller

The controller is mounted on a 35 mm DIN rail in the panel.

To fix the controller:

1. place the top of the controller hook onto the DIN rail;
2. rotate the controller to vertical position;
3. fix the controller by pushing the 2 slide hooks upward.

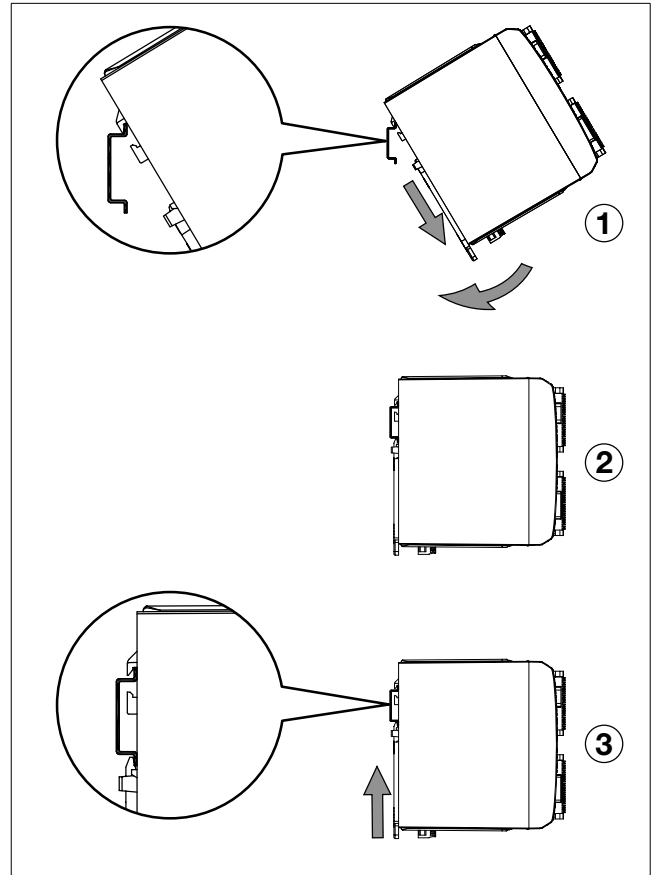

Figure 37 - Mounting on DIN rail

To remove the controller, release the 2 slide hooks by gently levering them with a screwdriver and then rotate the controller to free it.

Positioning

The controller is mounted **ONLY** horizontally.

When positioning it, be careful to respect the minimum distances between controller and cable channels and between controller and shielding bar (see Figure 14).

Also make certain that there is sufficient air circulation.

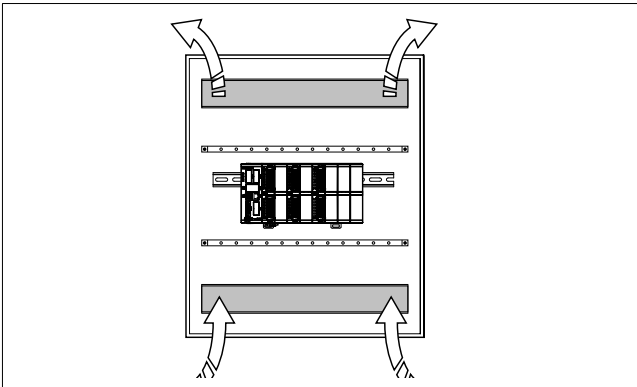

Figure 38 - ePCLoLogic400 air circulation

Mounting CPU and I/O modules



Warning: Switch off power to the controller before mounting or removing the modules.

The controller is completed by inserting the CPU module and I/O.

The I/O modules are available in two types: for digital signals (e41x) and positional signals (e43x).

The controller can contain up to 8 I/O modules and one CPU module or a smaller number if double-width modules are also used.

Follow these simple rules when mounting modules in the controller:

1. insert the modules starting from the CPU side (left)
2. analog modules are inserted first, starting from the slot closest to the CPU, then the functional I/O modules, and then the digital I/O modules;
3. unused slots are filled with blank module

Inserting a module

To insert a module:

1. check that the ePCLoLogic400 controller is not powered;
2. insert the module by positioning it correctly on the rack rails;
3. press until the front panel is hooked to the rack housings.

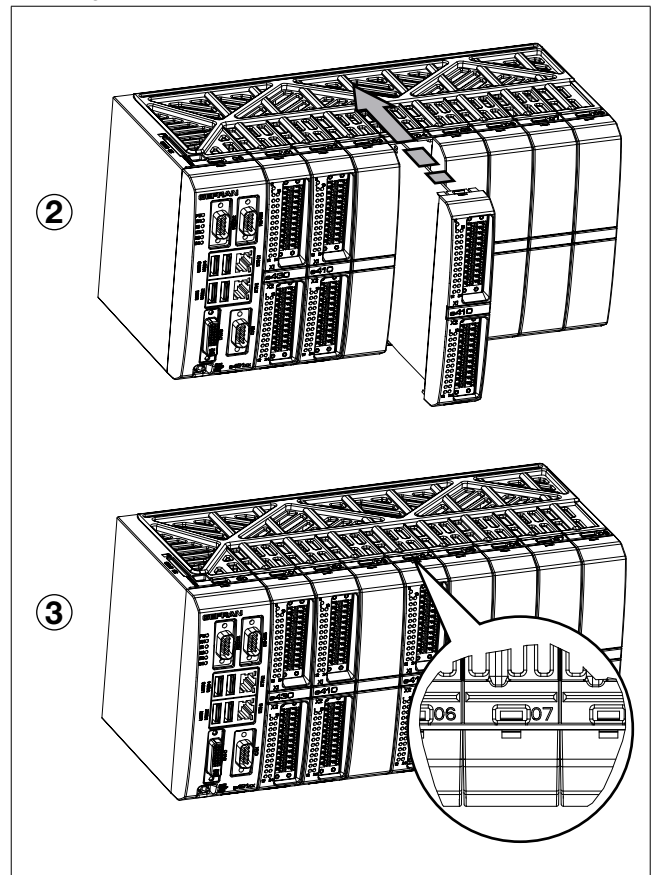

Figure 39 -- Inserting a module in the rack

Removing a module

To remove a module:

1. Check that the ePCLogic400 controller is not powered;
2. insert a screwdriver into the fastener slot;
3. gently lever with the screwdriver to release the module hook
4. slide the module from the rack.

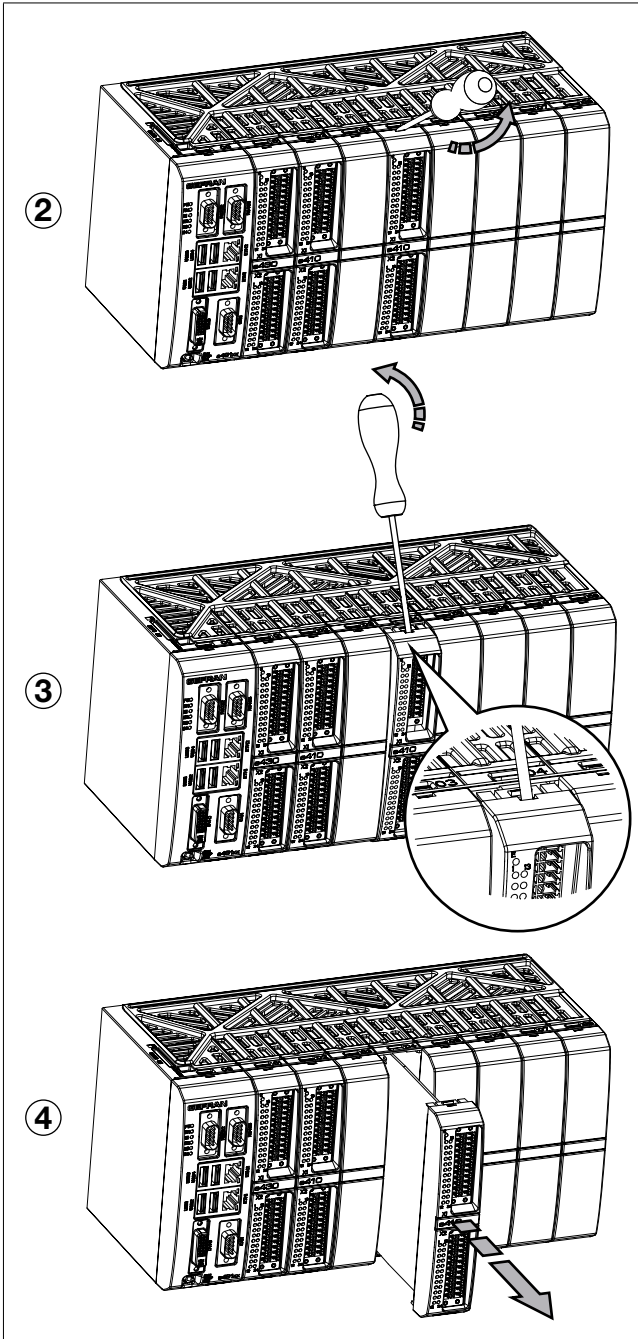

Figure 40 - Removing a module from the rack

Inserting a blank module

To complete the rack with a blank module, press the module into a free slot

remove a blank module, see “*Removing a module*” above

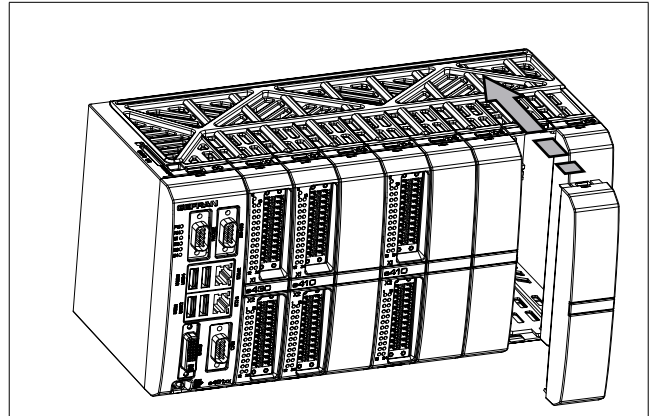

Figure 41 -Inserting a blank module in the rack

ePCLoGic400 Connections

Power

The ePCLoGic400 controller must be connected to a 24 Vdc power supply unit.

The same 24 Vdc power supply can feed the operator interface.

Make sure that the current issued by the power supply is higher than the total maximum current absorbed by all the devices connected.

Considering that the device has no switch, it is necessary to install one before it, with a protective fuse.

The switch has to be positioned in the immediate vicinity of the device and be easy for the operator to reach

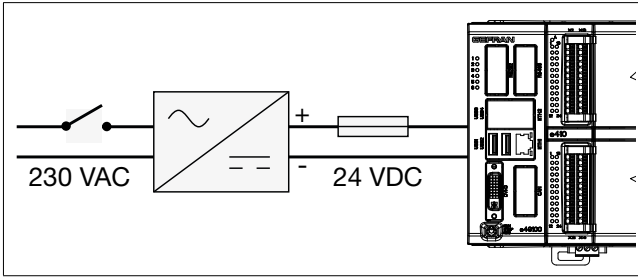

Figure 42 - Connector and power switch

For the 24 Vdc power supply unit, use a separate line from that used for electromechanical power devices such as relays, contactors, solenoids, etc.

If there are considerable changes in the mains voltage, use a voltage stabiliser.

Near to high frequency generators or arc welders, use adequate grid filters.

Connect the power cables to the power connector. Fit the ferrite, supplied with the product, as close as possible to the device to limit the susceptibility of the device to electromagnetic disturbance (Figure 43).

The 24 Vdc power supply cables must follow a separate path from the power cables of the plant or machine.

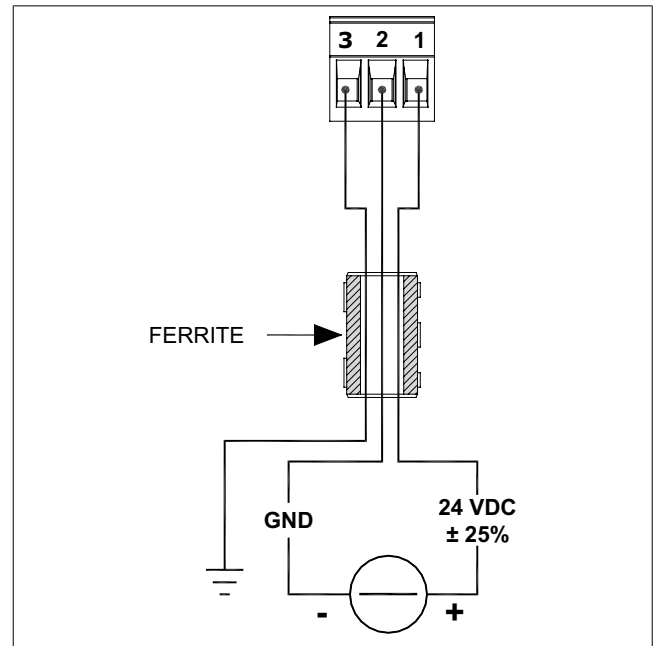

Figure 43 - ePCLoGic400 power connection

CPU module connections

Connectors, signals and configuration elements

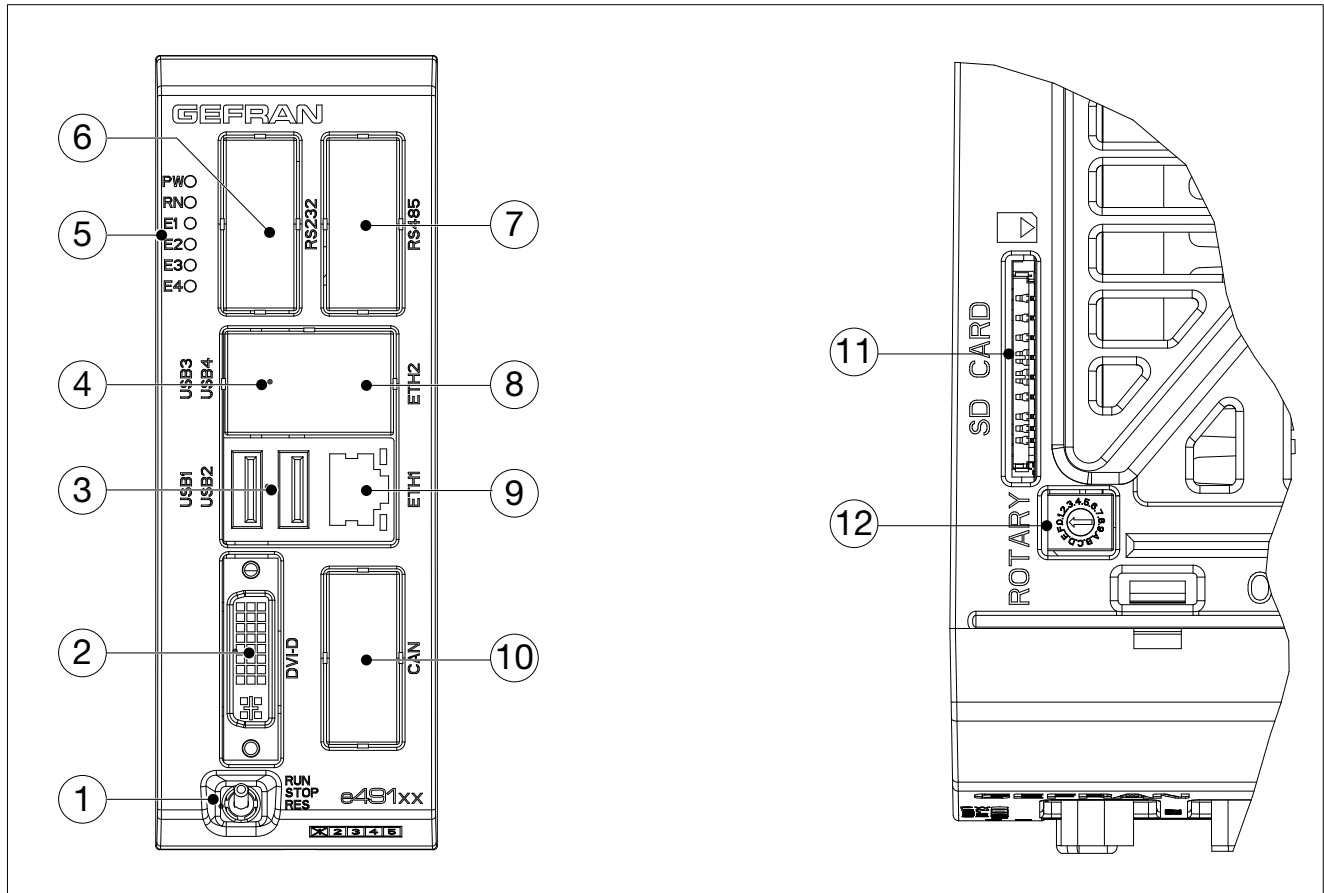

Figure 44 - Position of CPU module connectors, rotary selector and SD Card slot

No	Description	Connector / indicator	Notes
1	3-position selector (*)		
2	DVI-D output	DVI-D standard	to be connected to operator panel (DVI-D port)
3	USB Ports	Type A USB	one must be connected to the operator panel (Host USB port)
4	Supplemental USB ports	Type A USB	optional
5	LEDs	PW (yellow): power ON RN (green): PLC program status E1 (red): local I/O bus error E2 (red): HW Watchdog status E3 (red): SW Watchdog status E4 (red): PLC program status	
6	RS232 port	DB9 M (D-sub 9-pin male)	optional
7	RS485 port	DB9 M (D-sub 9-pin male)	optional
8	Supplemental Ethernet port	RJ45	optional
9	Ethernet port	RJ45	
10	CAN port	DB9 M (D-sub 9-pin male)	optional
11	SD Card Slot	Standard SD Card	SD Card not included
12	Rotary selector	16-position selector	default: 0

* currently not managed

Selector

3-position selector:

- currently not managed

DVI-D output

Use a standard DVI-D cable (maximum length: 5 meters) to connect the output to the DVI-D input on the operator panel.

USB

The USB ports are used to connect external devices conforming to the USB standard.

One of the ports is used to connect the controller to the USB HOST port (type B connector) on the operator panel. Printers cannot be connected.

The connectors are Type A and the ports support the USB 2.0 standards, with speed up to 480 Mbit/s.

The ports can deliver 500 mA current at 5 VDC to power external USB devices.

The USB cable can have a maximum length of 5 meters; use certified USB 2.0 cables.

Ethernet

Connect, if necessary, the Ethernet cable to the RJ45 Ethernet port. The Ethernet port lets you connect the controller to a computer or a corporate LAN.

Ethernet port 1 (ETH1) supports Modbus TCP protocol.

Ethernet port 2 (ETH2) can support Modbus TCP, GDNNet and EtherCAT protocol according to the order code.

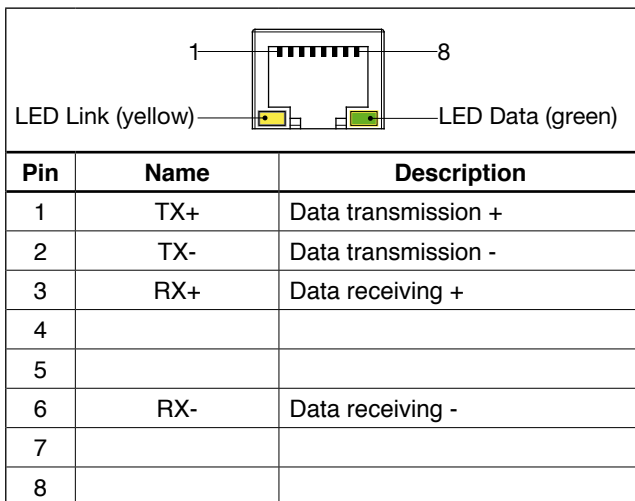

The connection cable to use, straight or crossover, depends on the type of device that should be connected.

For example, to connect directly to a PC with a crossover cable must be used.

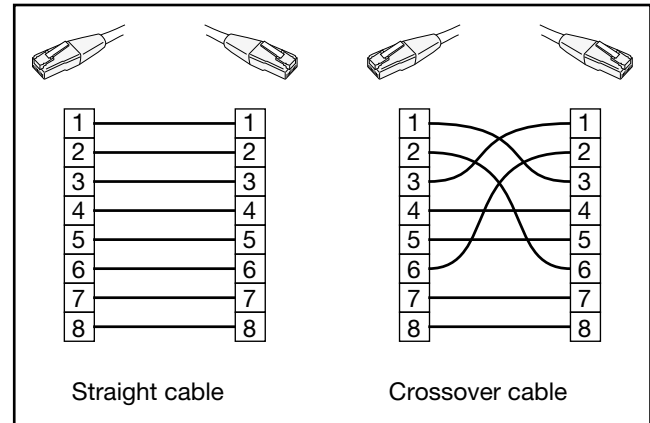

Figure 45 - Straight and crossover Ethernet cables

Use a CAT6 UTP or higher cable for the connection; you can use a standard CAT 5e cable only for EtherCAT. The maximum length of the Ethernet cable is 100 metres.

Do not run the Ethernet cable alongside the machine power cables, to avoid interference with data transmission.

The RJ45 socket has two LEDs. When the Ethernet connection is active, the green LED stays permanently lit; when data is being transmitted, the yellow LED flashes

RS232

The RS232 port is optional. Considering that the RS232 port is not insulated, it is necessary to disconnect the power to the Integrated Controller and Operator Panel and to the device to be connected before connecting them.

The connection cable must be screened and not exceed a length of 5 metres.

Tighten the cable connector to that of the controller using the special screws.

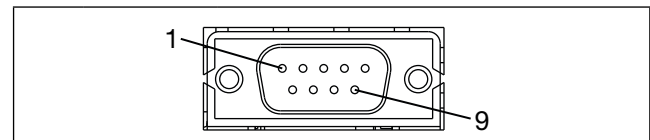

Pin	Name	Description	Signal
1	DCD	Data Carrier Detect	Input
2	RxD	Received Data	Input
3	TxD	Transmitted Data	Output
4	DTR	Data Terminal Ready	Output
5	GND	Ground	Ground
6	DSR	Data Set Ready	Input
7	RTS	Request To Send	Output
8	CTS	Clear To Send	Input
9	RI	Ring Indicator	Input

RS485

The RS485 port is optional. Considering that the RS485 is opto-isolated, it is not necessary to disconnect the power to the Integrated Controller and to the device to be connected before connecting them.

Tighten the cable connector to that of the controller using the special screws

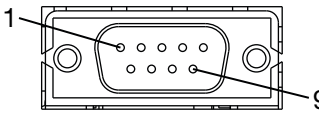

Pin	Name	Description
1		
2	TX/RX+	Data +
3		
4	TX/RX-	Data -
5	GND	Ground
6		
7		
8		
9		

Do not connect any filters other than the ones described. The RS485 connection can be used successfully over long distances and in environments characterised by considerable disturbance.

The maximum length of the cable depends on the transmission speed, as shown in figure 47.



Warning: The RS485 port is equipped with internal termination and polarization, as shown in the figure below.

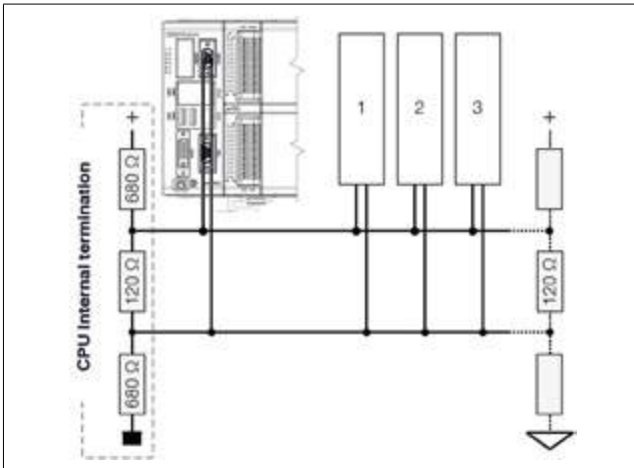

Figure 46 - Polarizations and line termination RS485

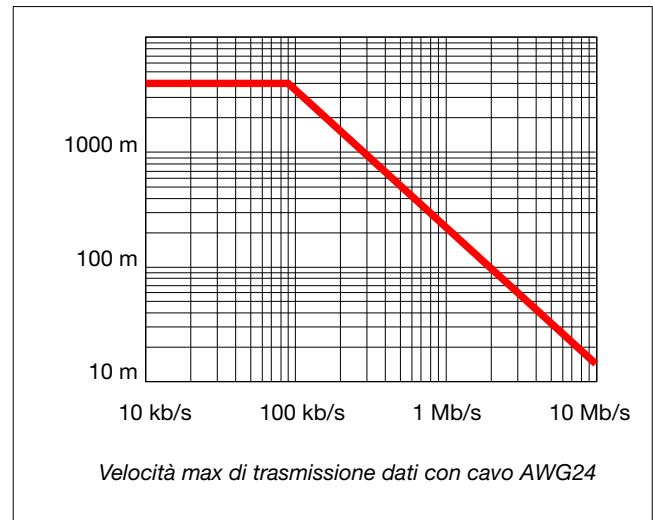

Figure 47 - RS485 max transmission speed

CAN

Connect the cable for the CAN field bus. The CAN bus is used to connect to the controller devices that conform to the CANopen standard.

Considering that the CAN port is opto-isolated, it is not necessary to disconnect the power to the device before connecting it.

For the wiring of the line, use an approved cable. Fasten the cable connector to that of the controller with the appropriate screws.

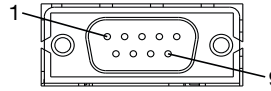

Pin	Name	Description
1		
2	CAN_L	CAN-Low (CAN-)
3	GND	Ground (massa)
4		
5	EARTH	Terra
6		
7	CAN_H	CAN-High (CAN+)
8		
9		

Do not connect any filters other than the ones described.



Warning: The CAN port does not have a line terminator. If the CPU module is the first or the last device on the CAN line, you have to insert a terminator (120 Ω resistor, 1/4 W, 5%) at the end of the CAN bus, as shown in Figure 48.

Remember that the CAN bus must be terminated at both ends

Figure 49 shows the correlation between CAN bus length and maximum transmission speed.

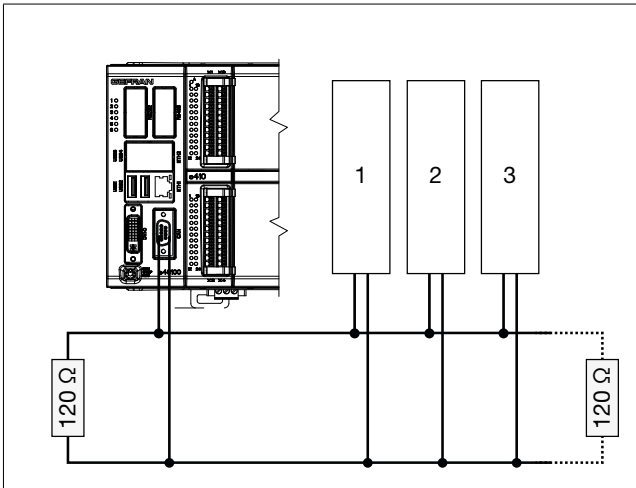

Figure 48 - CAN bus line termination

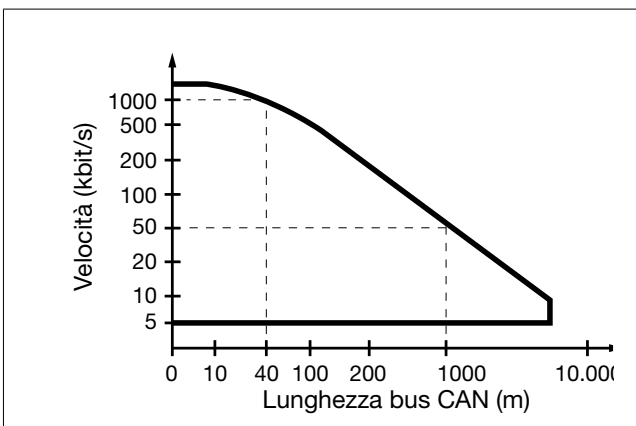

Figure 49 - Maximum CAN bus transmission speed

Figure 50 shows the guidelines for installing a CAN network with GEFRAN and/or third-party devices.

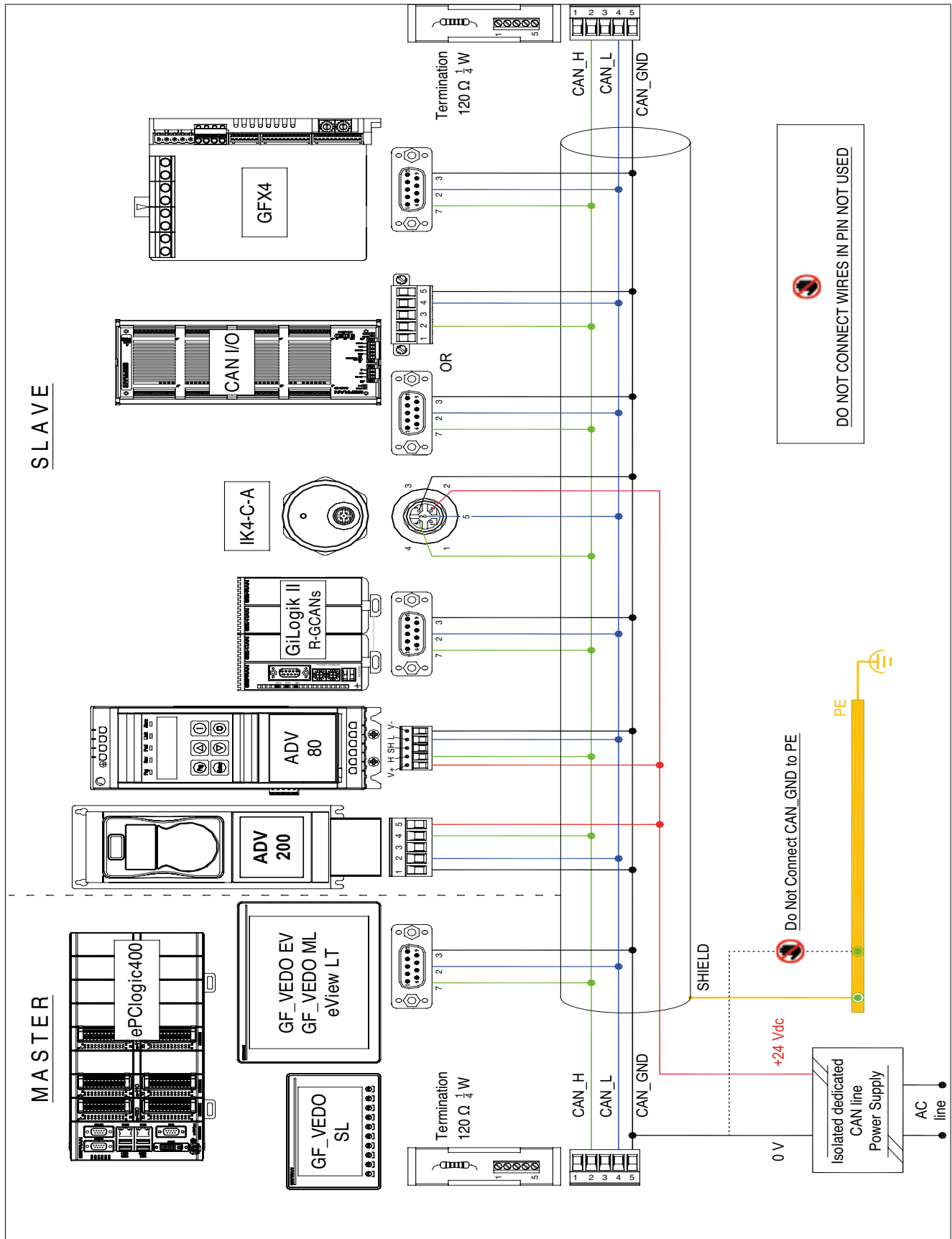

Figure 50 - CAN guidelines

Rotary selector

The rotary selector is used to set the function of the CPU module. Settings and functions:

- **0 to 9:** normal operation.
- **A:** power-on – user application from SD-Card..
- **B, C:** reserved – do not use.
- **D:** runtime – diagnostics mode.
- **E:** reserved – do not use
- **F:** power-on - start in setup mode

SD Card

The SD Card mass memory lets you store data and applications.

SD Card function is defined by rotary selector position (use positions 0 to 9 only; unless otherwise instructed, do not use positions A to F).

Wiring I/O module connectors

Connecting the cables

The cables are required to spring into the connectors for the I/O module inputs and outputs.

The cable can be wired either lugged or stripped. If stripped, remove 7-9 mm of sheath to ensure perfect contact.

If the cable is lugged, simply push it into the connector housing.

If it is stripped, open the contact by pushing the small white button, insert the cable in the connector housing, then release the button.

To remove the cable push the small white button.

Reducing mechanical tension on cables

Reduce the mechanical tension that the cables exert on the connections by fastening the cables with clips or other holding systems to the structure housing the ePCLoGic400.

Grounding shielding

The shielding of all shielded cables must be grounded.

As a rule (unless otherwise necessary), the shielding should be grounded on the side of the signal source.



Warning: the ground connection should be as short as possible and have the least possible resistance.



Warning: if the connection is made directly from the braid, make sure the cable is firmly attached to eliminate all mechanical tension from the cable on the ground connection.

I/O modules connectors

Inserting a connector

Insert a connector in an I/O module as follows:

1. Rotate the 2 extractors (Fig.51.1), and insert it fully into the I/O module.

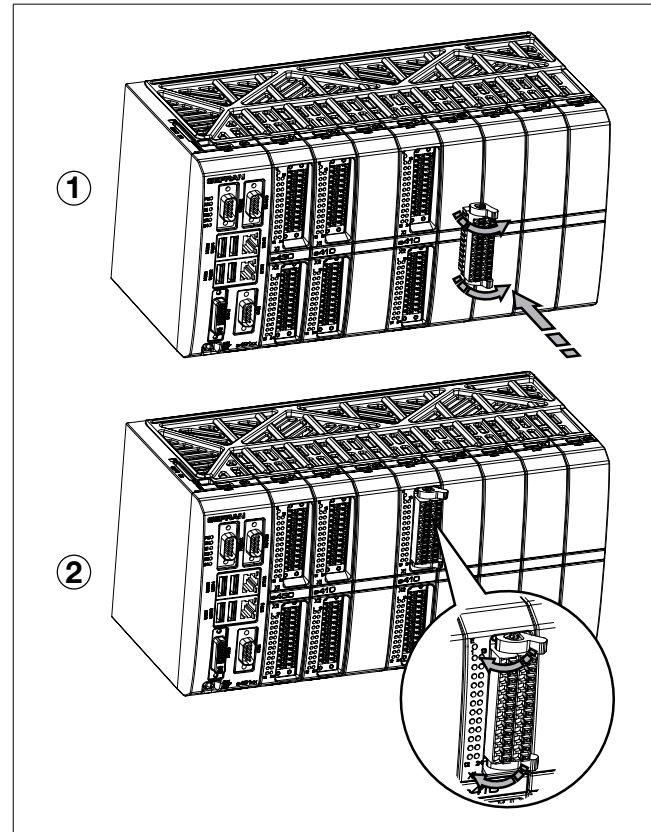

Figure 51 - Inserting a connector in an I/O module

Removing a connector

Remove a connector from an I/O module as follows:

1. Rotate the 2 extractors (Fig.51.2) and pull the connector from the I / O module.



Warning: to remove the connector, pull the connector body, not the connected wires.

e410 module connections

Connectors and signals

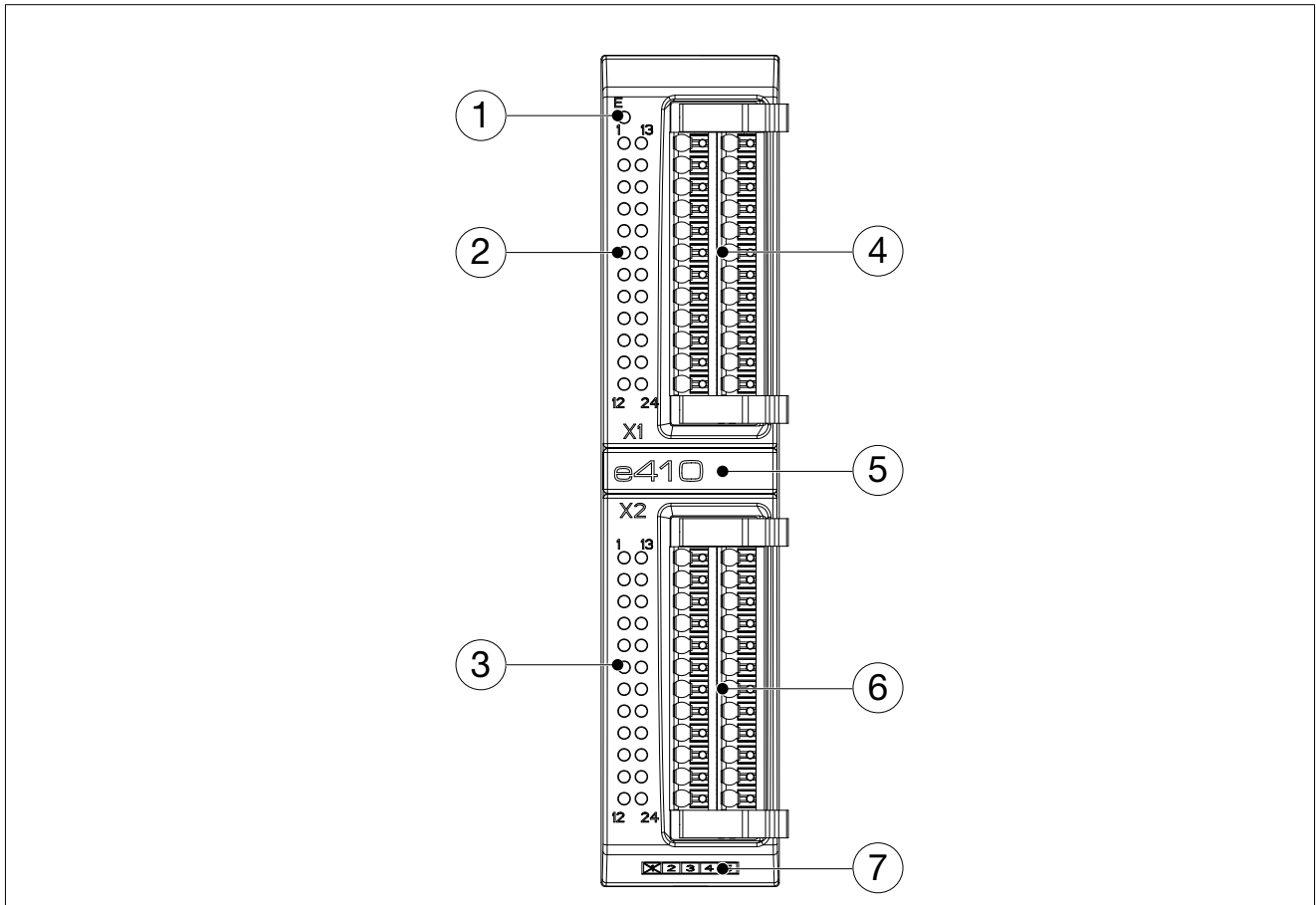

No	Description	Connector / indicator	Notes
1	Error LED		OFF: normal operation ON: alarms signaled Power ON: on for a few seconds
2	X1 I/O LED	1, 7 = Power	ON: power present for output
		2...6 = DO1...DO5 digital outputs status 8...12 = DO6...DO10 digital outputs status	ON: output on OFF: output off
		14...17 = DI1...DI4 digital inputs status 20...23 = DI1...DI8 digital inputs status	ON: input on OFF: input off
3	X2 I/O LED	1, 7 = Power	ON: power on
		2...6 = DO11...DO15 digital outputs status 8...12 = DO16...DO20 digital outputs status	ON: output on OFF: output off
		14...17 = DI9...DI3 digital inputs status 20...23 = DI14...DI6 digital inputs status	ON: input on OFF: input off
4	X1 connection	Weidmüller connector model 142875 BCF3.81/24/180LH BK BX SO	Max cable section: 1,5 mm ²
5	Module name		
6	X2 connection	Weidmüller connector model 142875 BCF3.81/24/180LH BK BX SO	Max cable section: 1,5 mm ²
7	Card revision code		

e410 connection diagrams

Connector pinout

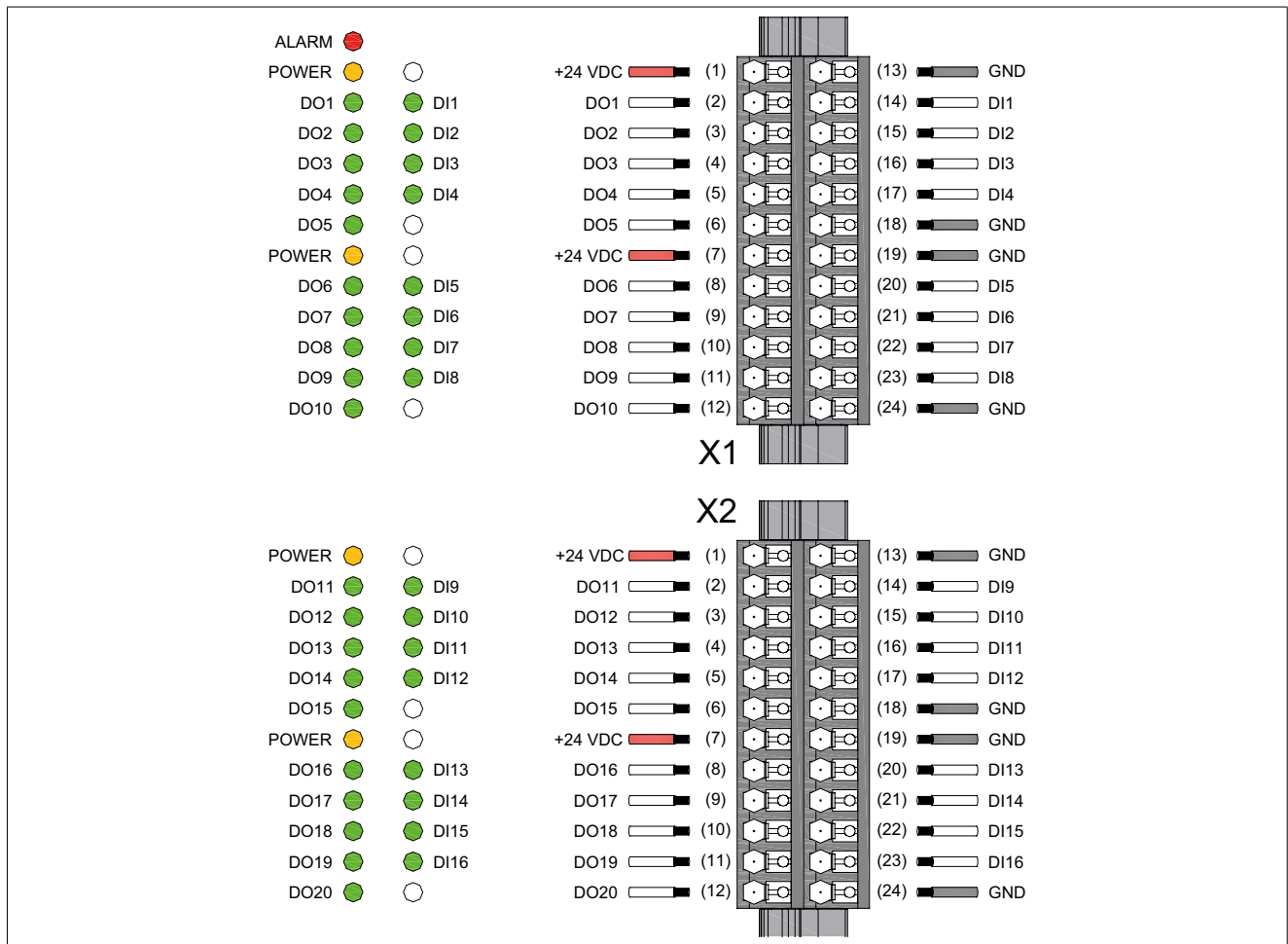

ON/OFF digital input and output

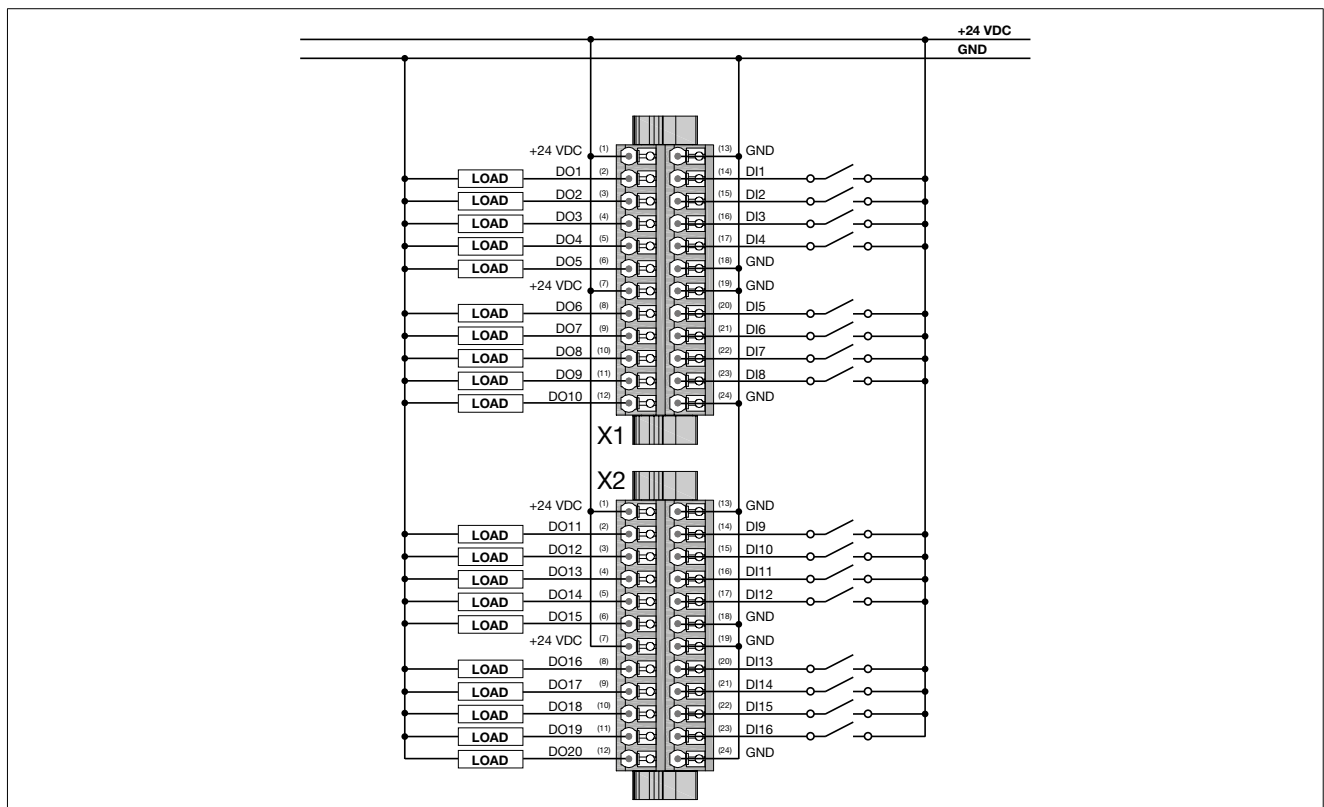

Digital input - Unidirectional encoder with zero

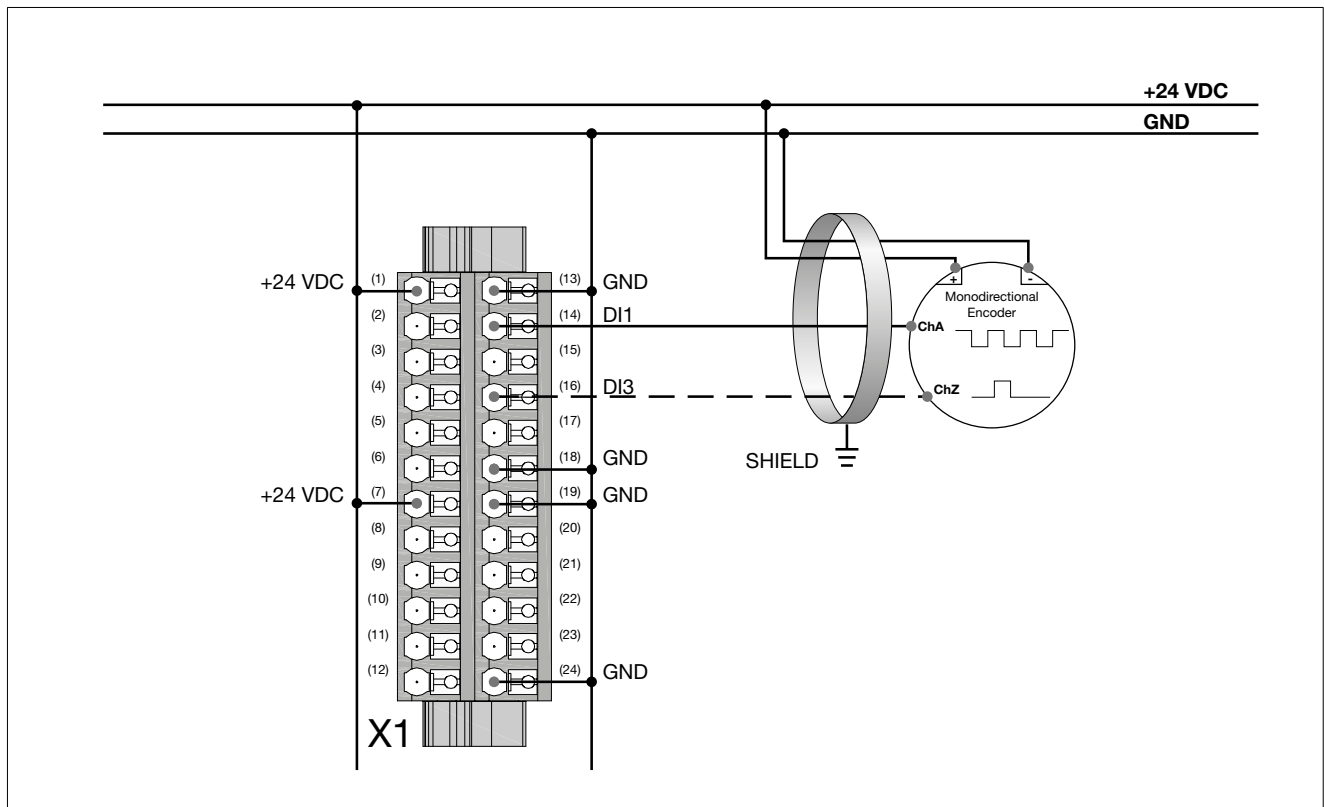

Use a screened cable with 4 conductors and connect the screening to the earth bar as close as possible to the module. The input has to be configured via software.

Digital input - Bidirectional encoder with or without zero

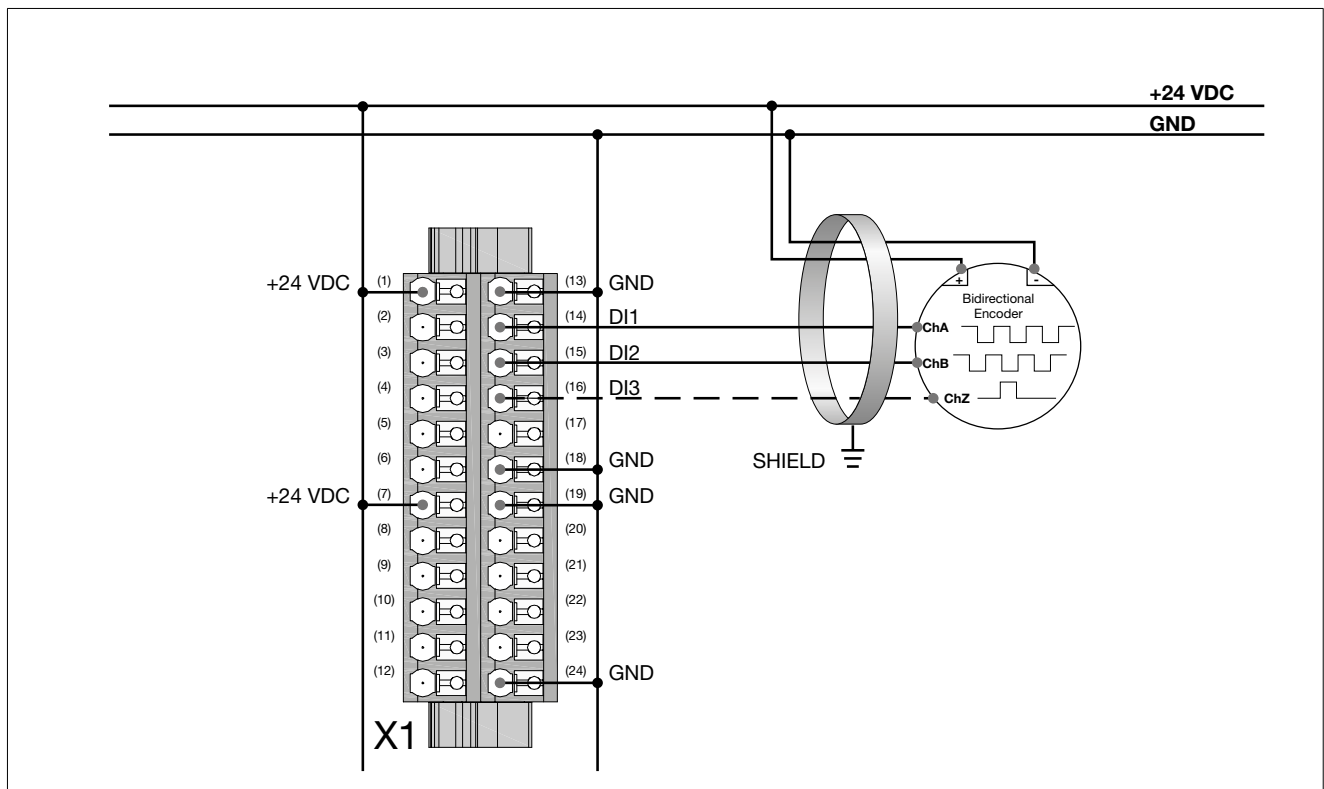

Use a screened cable with 5 conductors and connect the screening to the earth bar as close as possible to the module. The input has to be configured via software.

Digital input - Pulse counter / encoder without zero-way

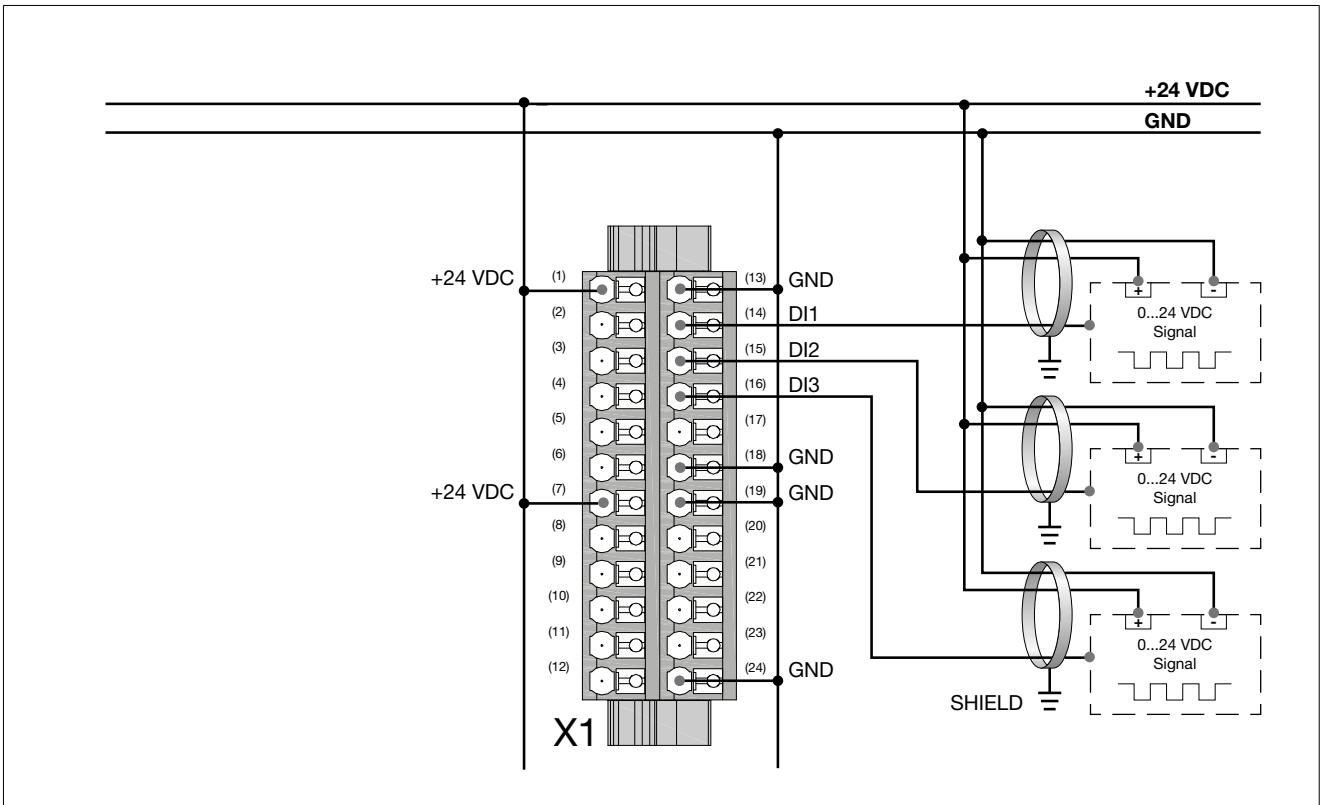

Use a screened cable with 3 conductors and connect the screening to the earth bar as close as possible to the module. The input has to be configured via software.

Digital output - PWM

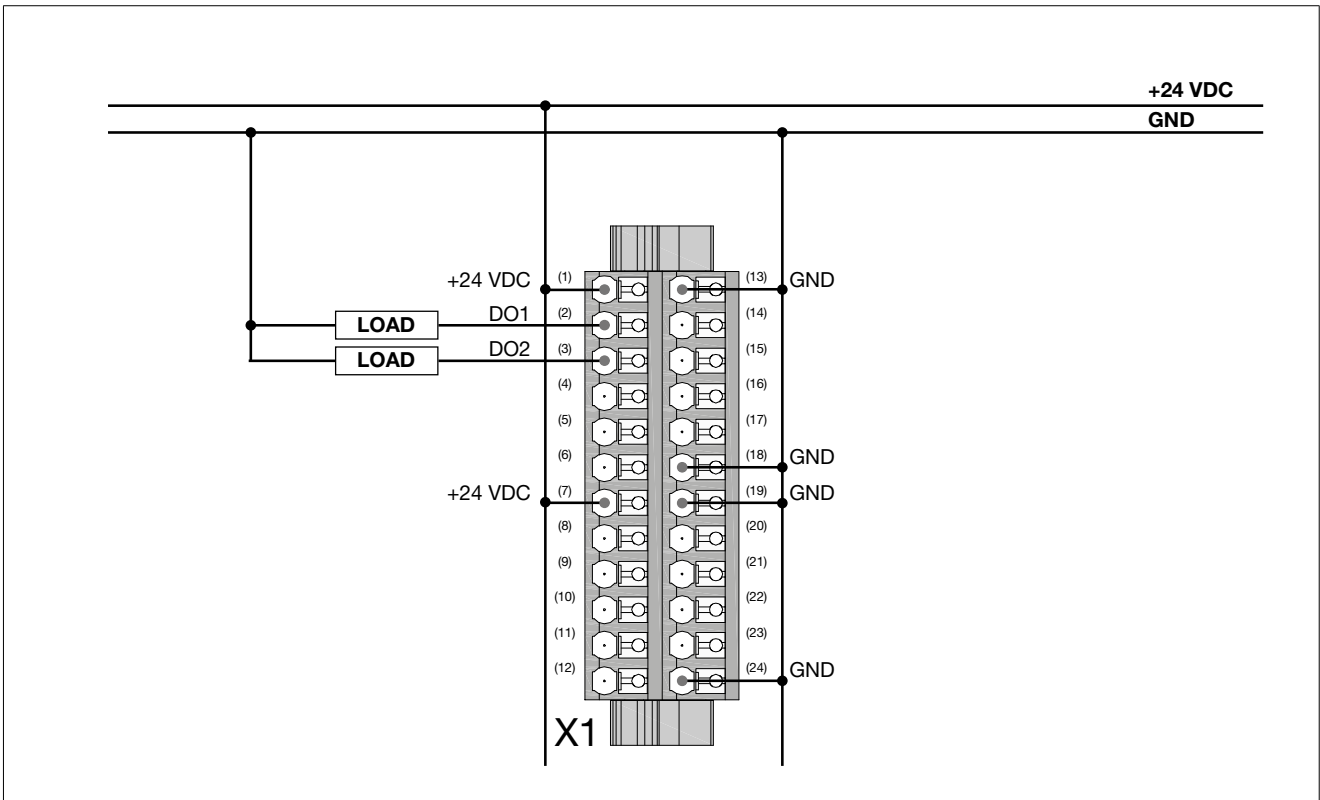

e411 module connections

Connectors and signals

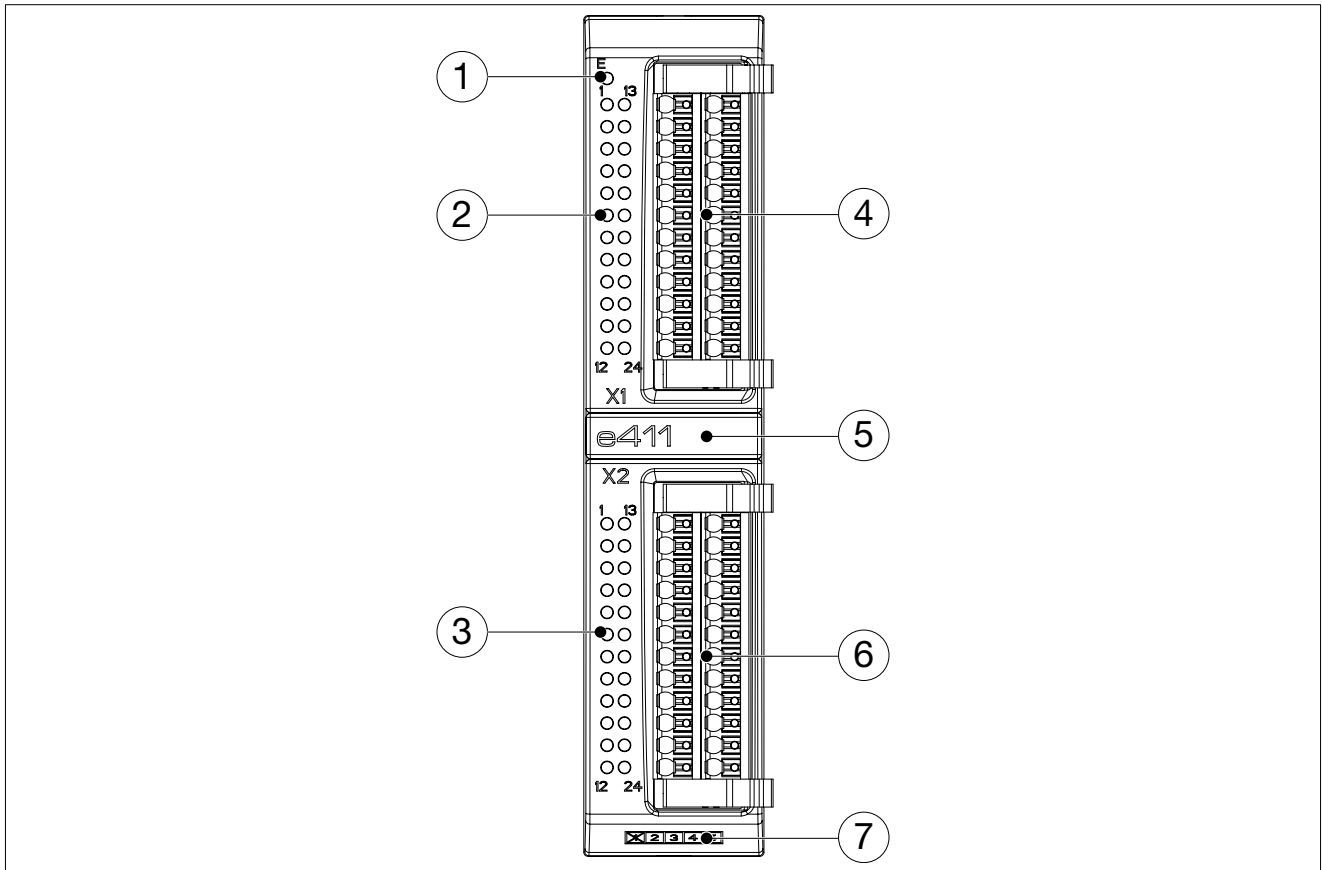

No	Description	Connector / indicator	Notes
1	Error LED		OFF: normal operation ON: alarms signaled Power ON: on for a few seconds
2	X1 I/O LED	1, 7 = Power	ON: power present for output
		4...6 = DO1...DO3 digital outputs status 8...12 = DO4...DO8 digital outputs status	ON: output on OFF: output off
		14...17 = DI1...DI4 digital inputs status 20...23 = DI1...DI8 digital inputs status	ON: input on OFF: input off
3	X2 I/O LED	1, 7 = Power	ON: power on
		4...6 = DO9...DO11 digital outputs status 8...12 = DO12...DO16 digital outputs status	ON: output on OFF: output off
		14...17 = DI9...DI3 digital inputs status 20...23 = DI14...DI6 digital inputs status	ON: input on OFF: input off
4	X1 connection	Weidmüller connector model 142875 BCF3.81/24/180LH BK BX SO	Max cable section: 1,5 mm ²
5	Module name		
6	X2 connection	Weidmüller connector model 142875 BCF3.81/24/180LH BK BX SO	Max cable section: 1,5 mm ²
7	Card revision code		

e411 connection diagrams

Connector pinout

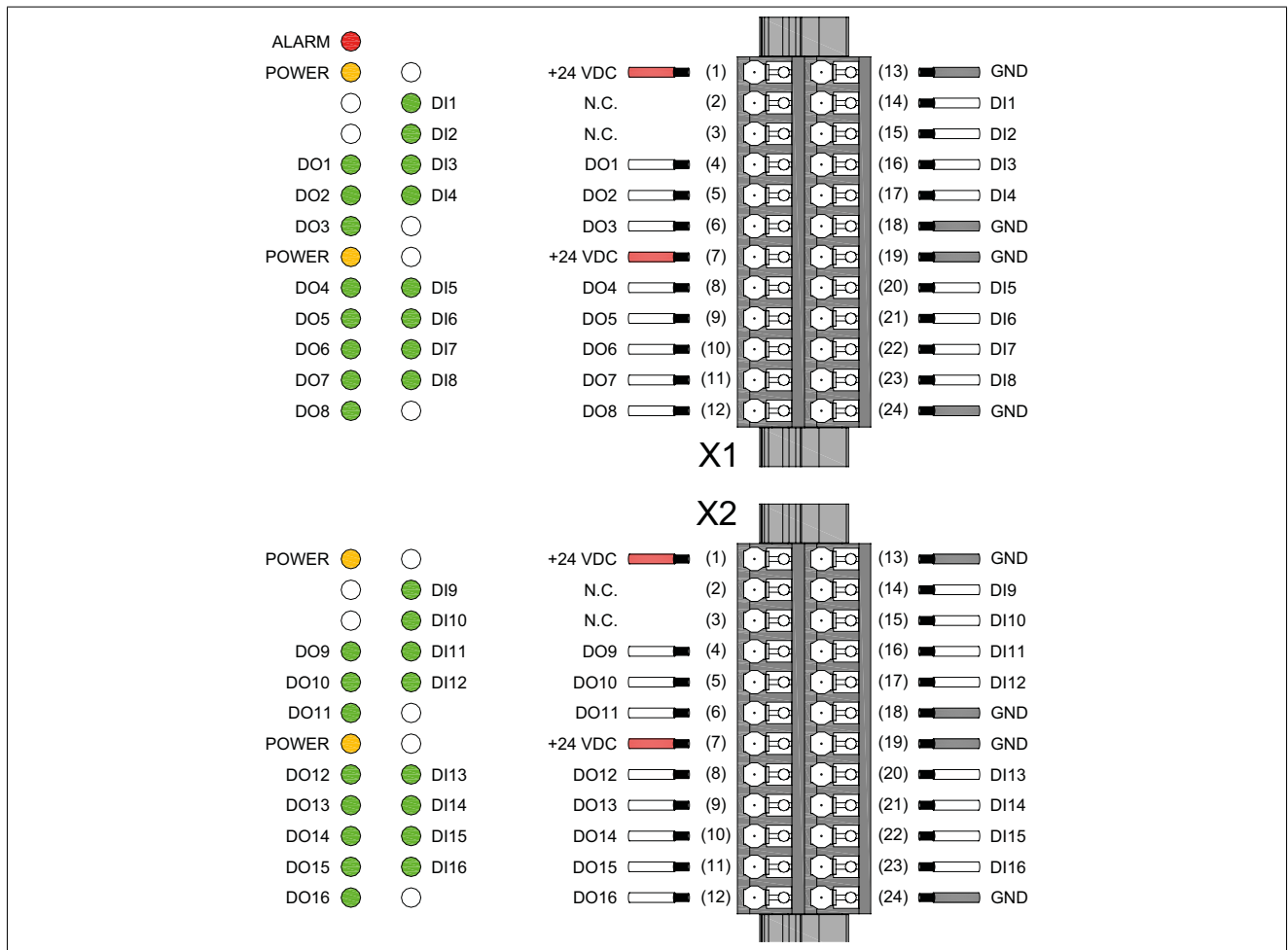

ON/OFF digital input and output

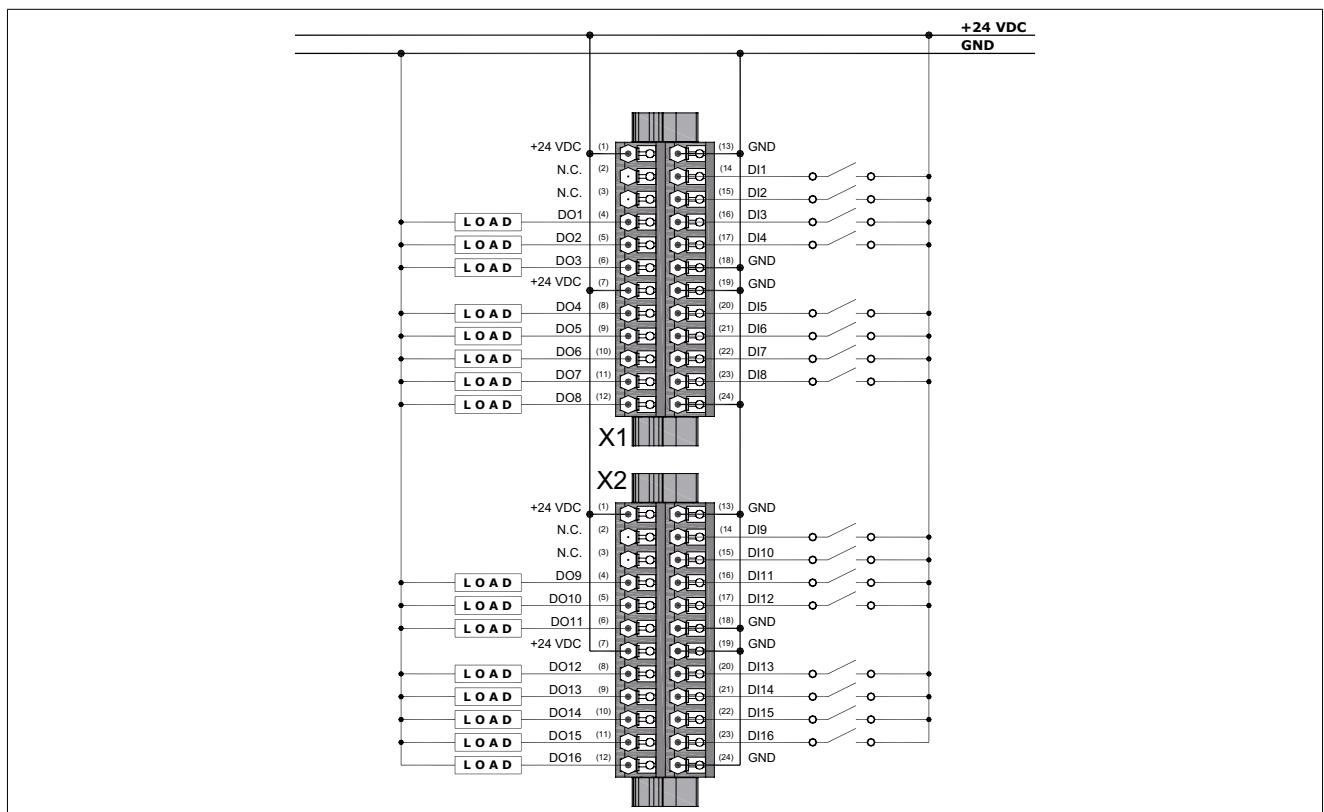

e430 module connections

Connectors and signals

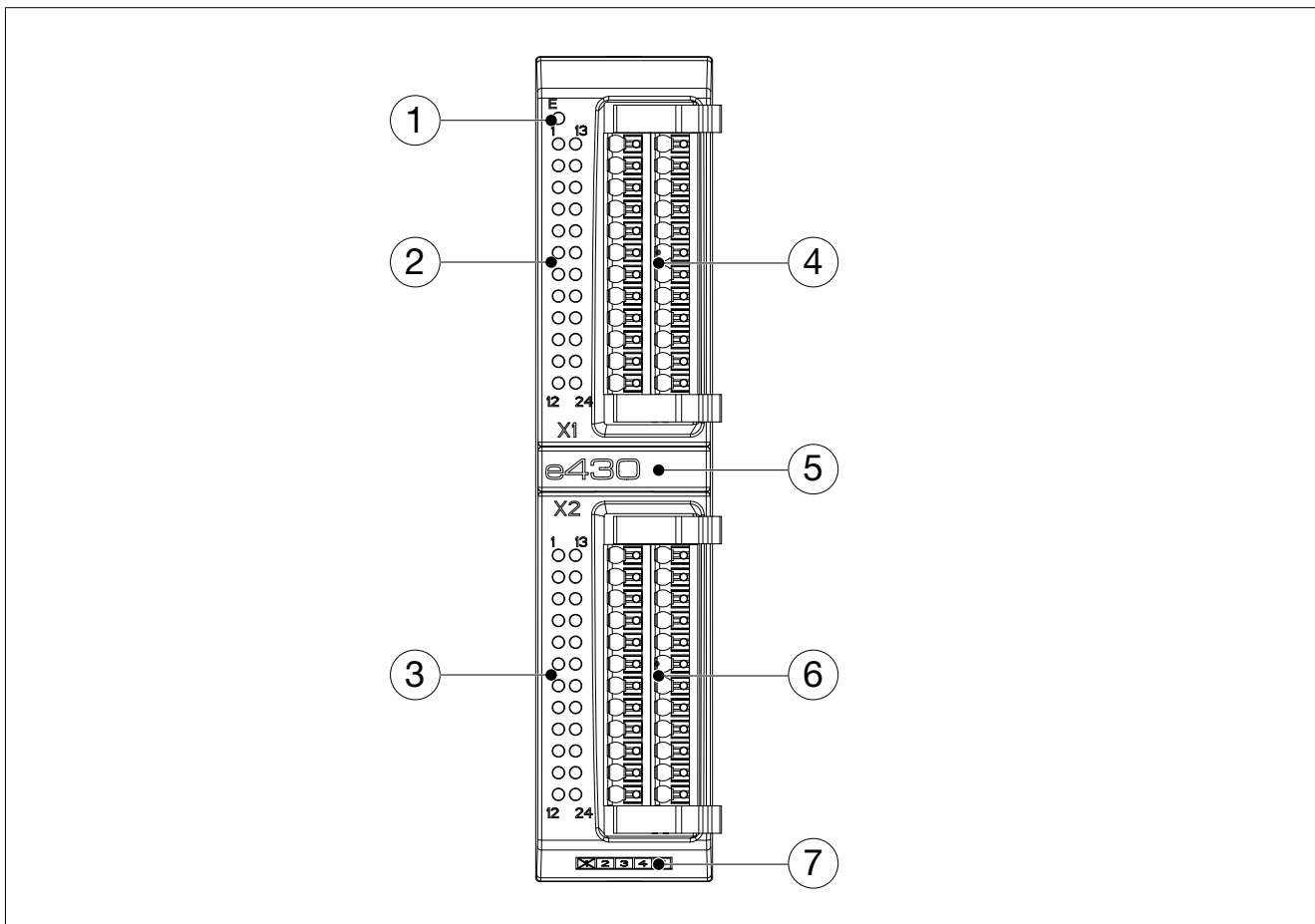

No	Description	Connector / indicator	Notes
1	Error LED		OFF: normal operation ON: alarms signalled Power ON: on for a few seconds
2	X1 I/O LED	1 = power	Always on
3	X2 I/O LED	not used	not used
4	X1 connection	Weidmüller connector model 142875 BCF3.81/24/180LH BK BX S0	Max cables section: 1,5 mm ²
5	Module name		
6	X2 connection	Weidmüller connector model 142875 BCF3.81/24/180LH BK BX S0	Max cables section: 1,5 mm ²
7	Card revision code		

Connector pinout

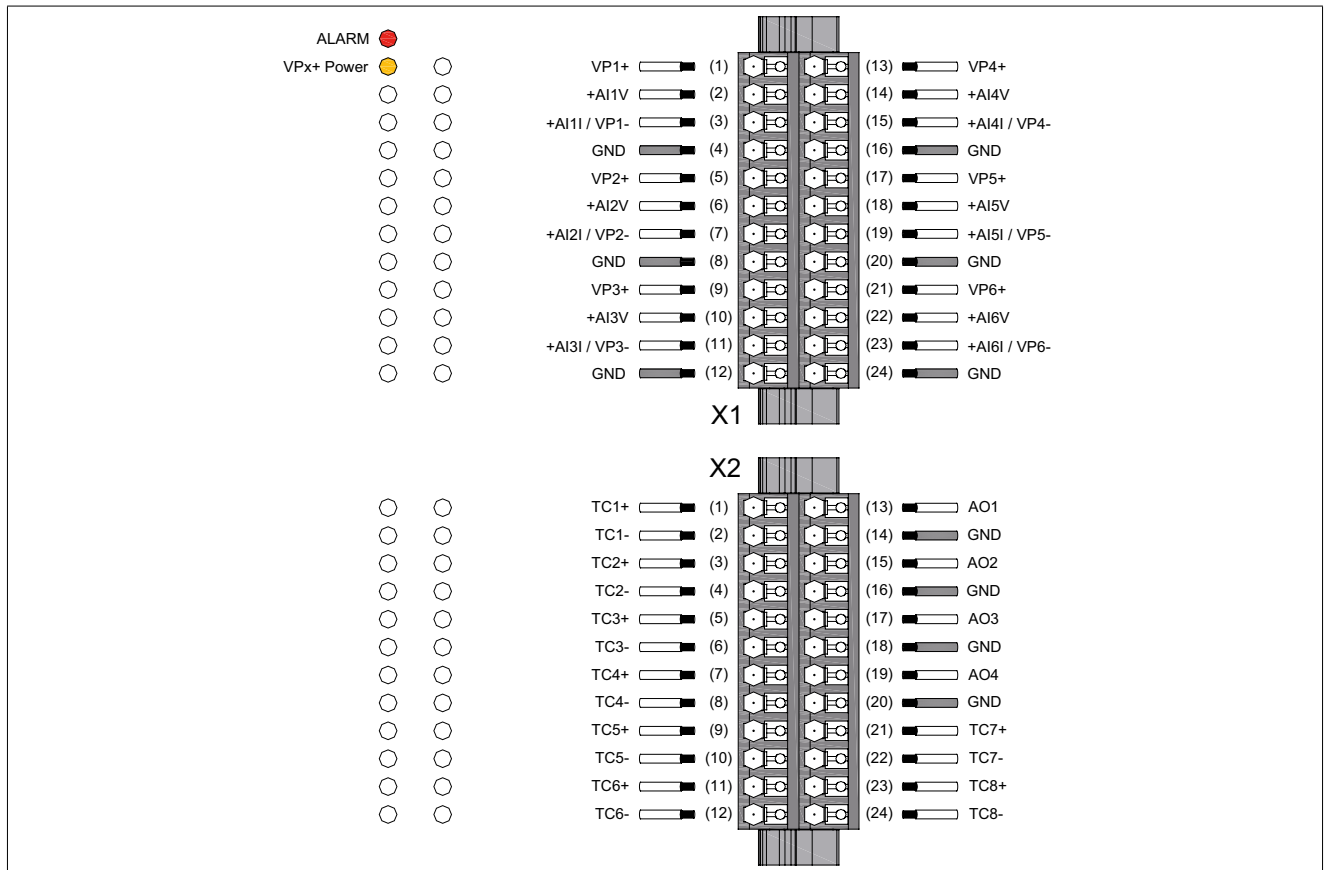

e430 connection diagrams

Analog voltage input

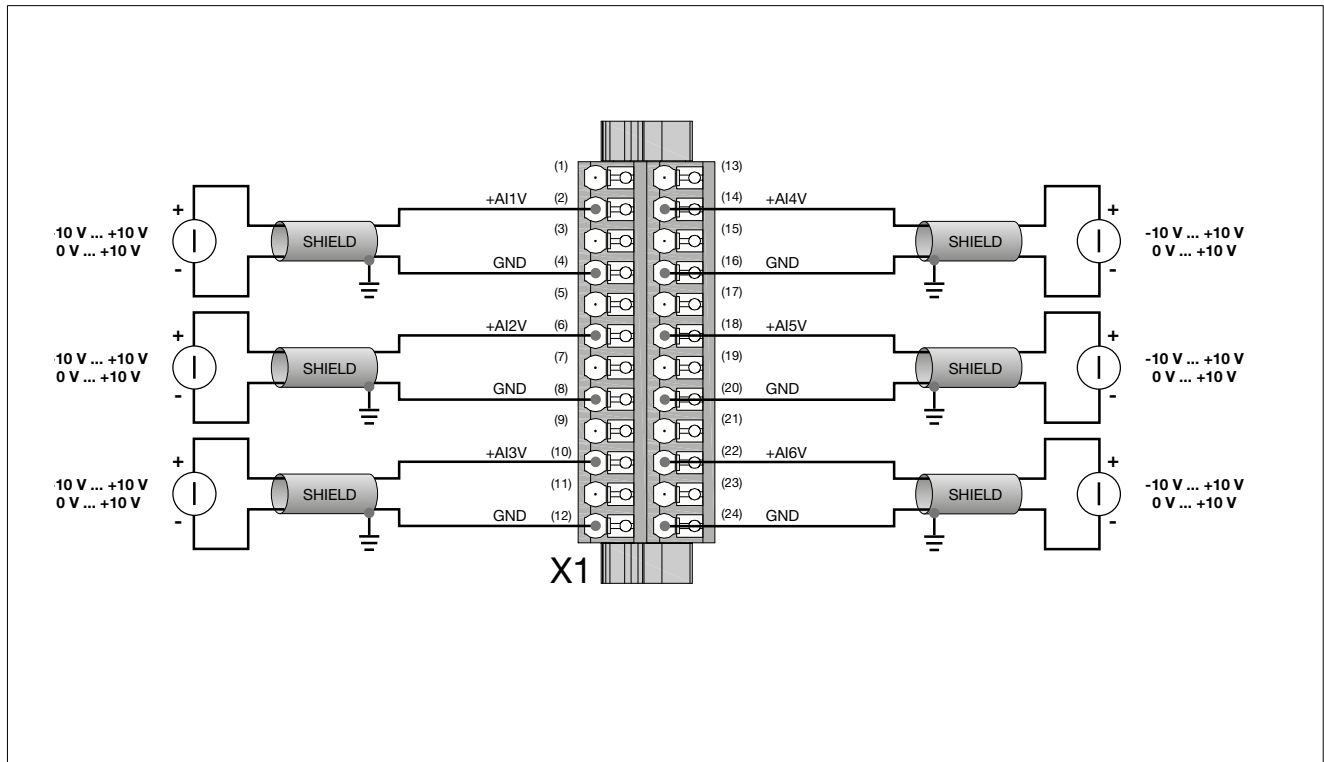

Use a shielded bipolar cable and connect the shielding to the grounding bar as close as possible to the voltage source.

Analog input in current

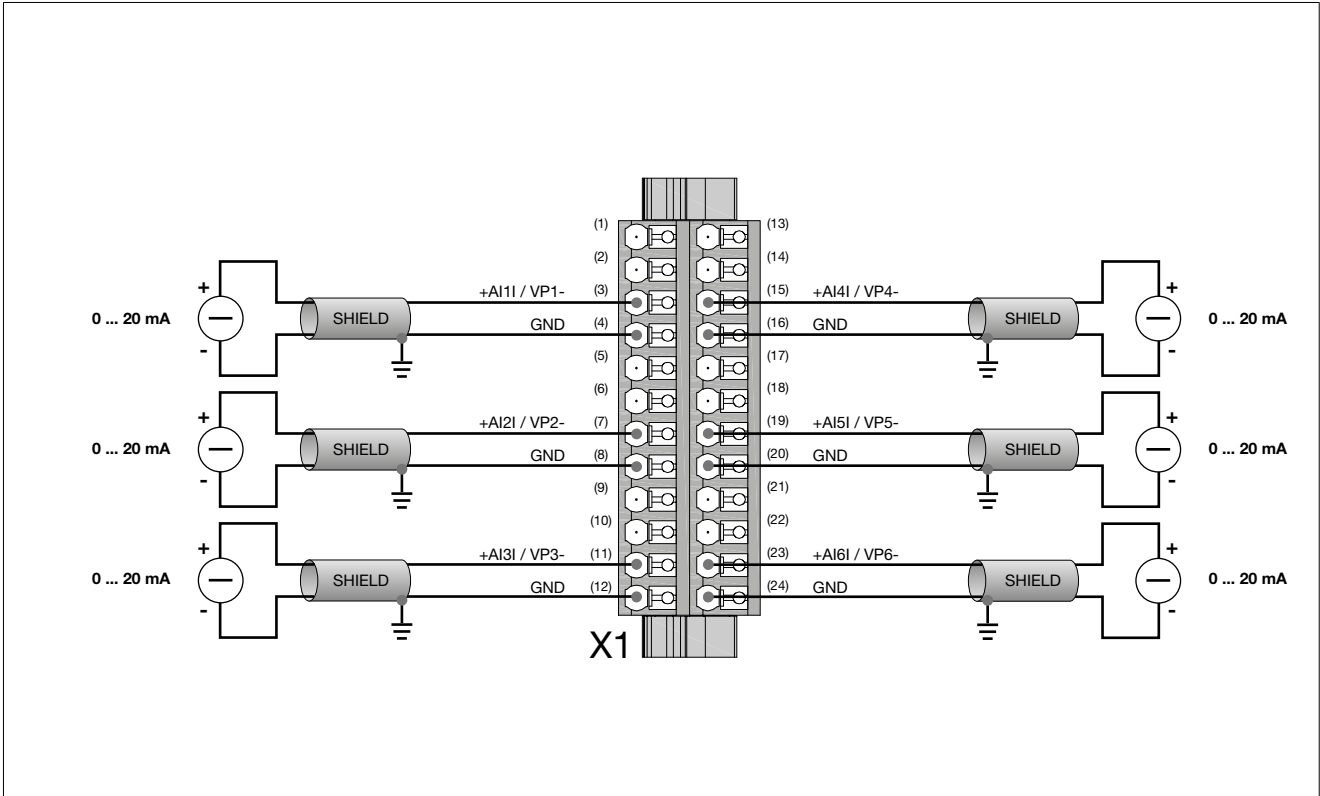

Use a screened bipolar cable and connect the screening to the earth bar as close as possible to the source of voltage.

Analog input - Thermocouple

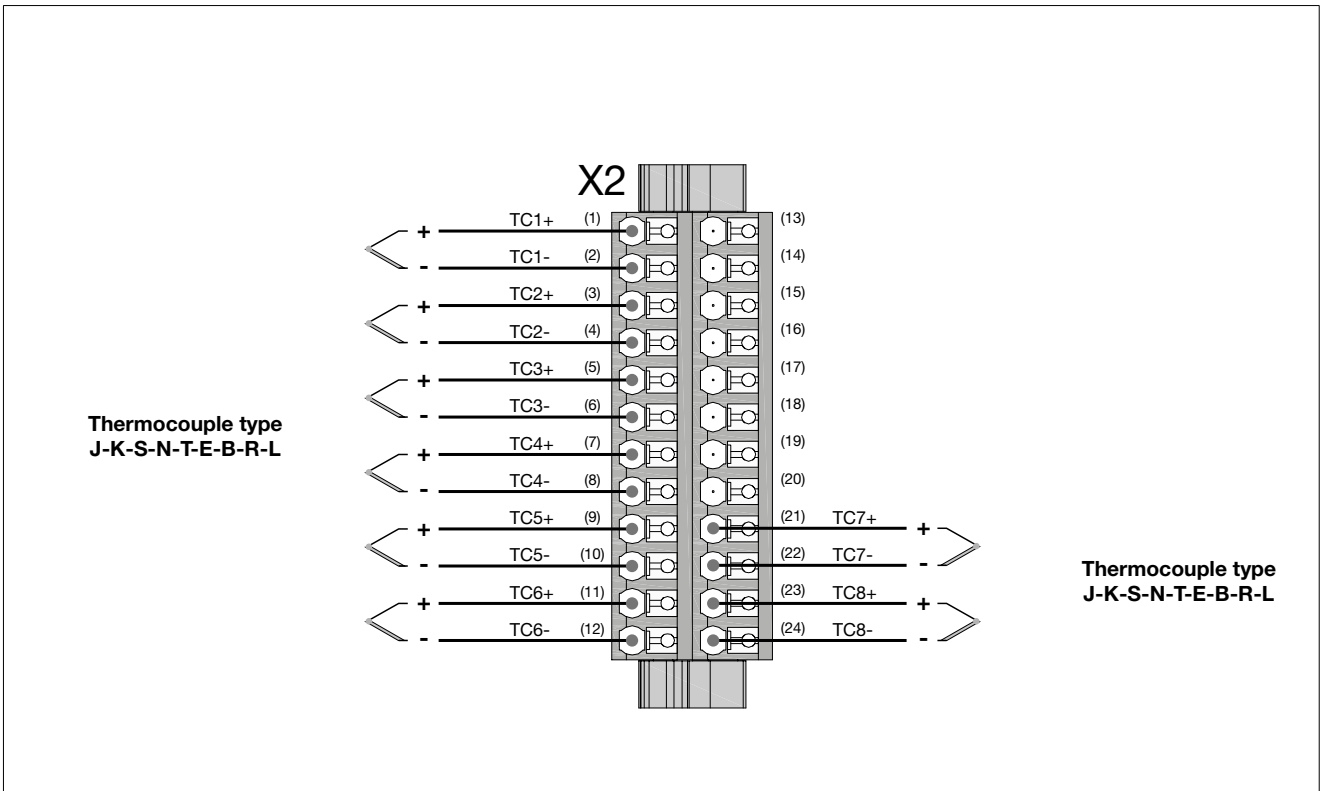

For the connection use a compensated cable. If using a screened cable, connect the screening to the earth bar as close as possible to the probe. The screening is connected to earth on the hot joint of the probe.

Potentiometer analog input

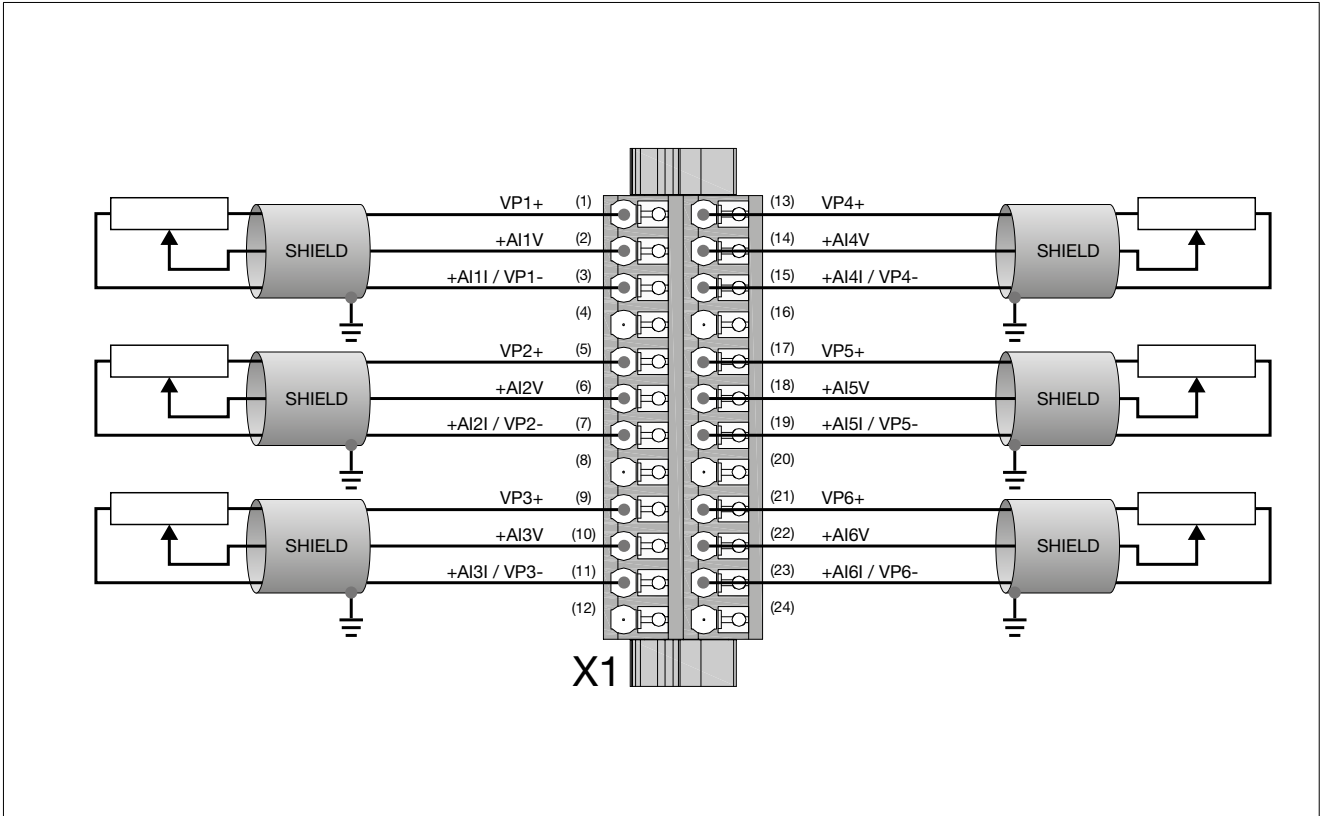

Use a screened cable with 3 conductors and connect the screening to the earth bar as close as possible to the module. The potentiometer must have a resistance value greater than or equal to 2 k Ω .

Analog input in voltage

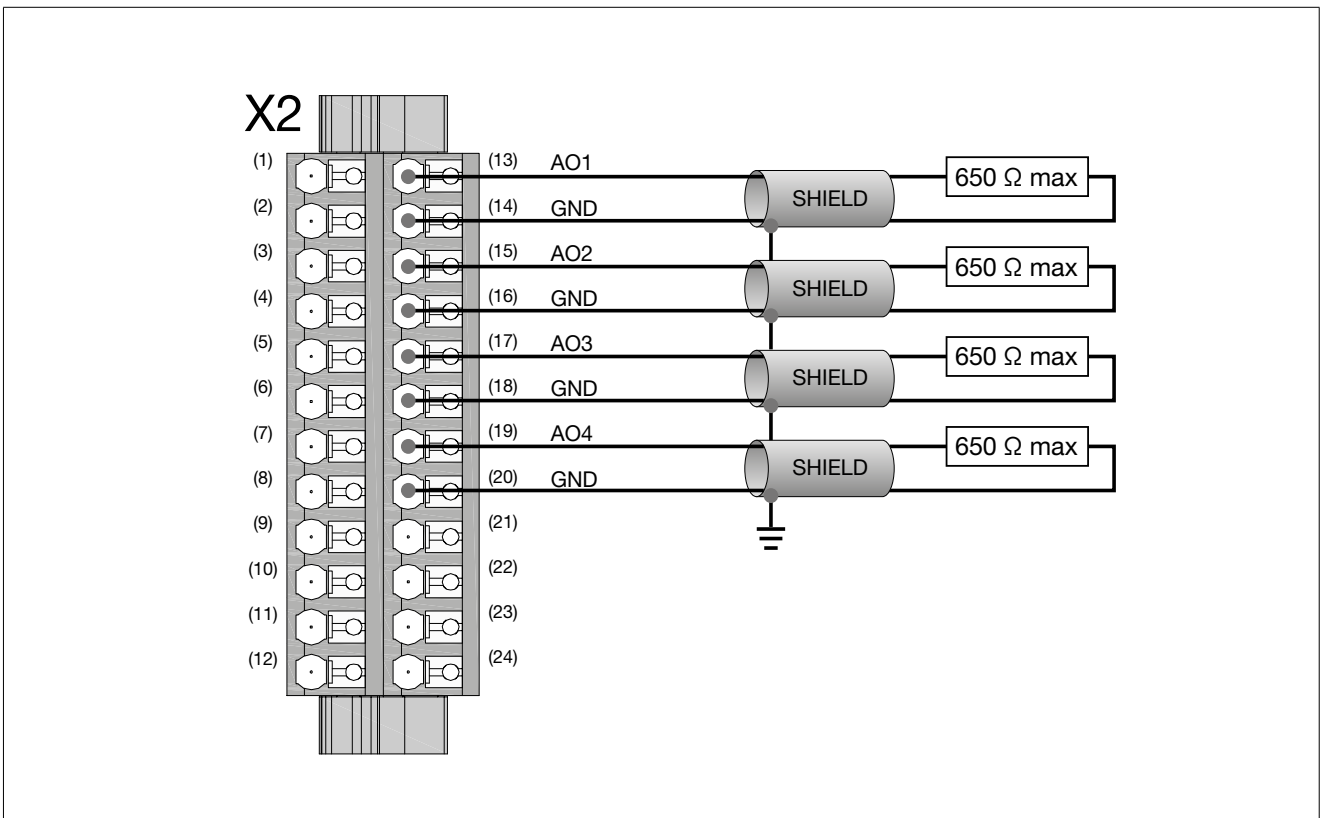

Use a screened cable with 3 conductors and connect the screening to the earth bar as close as possible to the module. The input has to be configured via software.

e431 module connections

Connectors and signals

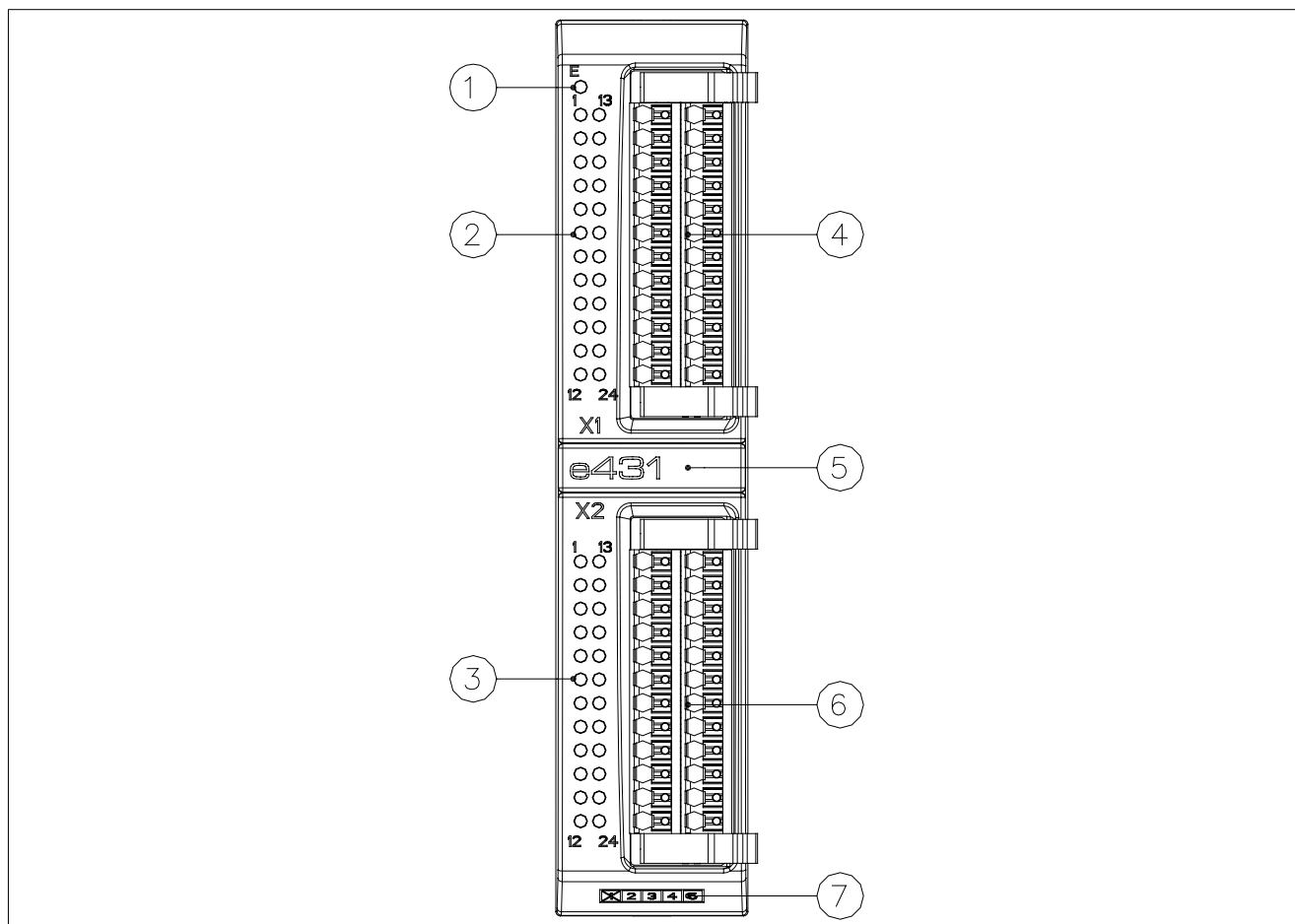

N.	Description	Connector / indicator	Notes
1	LED Error		OFF: normal operation ON: alarms signaled Power ON: on for a few seconds
2	LED I/O X1	1, 10, 19 = Power	ON: power for outputs
		2...9 = State digital outputs DO1...DO8 11...18 = State digital outputs DO9...DO16	ON: active output OFF: not active output
3	LED I/O X2	not used	not used
4	X1 Connection	Weidmüller connector model 142875 BCF3.81/24/180LH BK BX S0	Max cable section: 1,5 mm ²
5	Module name		
6	X2 Connection	Weidmüller connector model 142875 BCF3.81/24/180LH BK BX S0	Max cable section: 1,5 mm ²
7	Card revision code		

Connector pinout

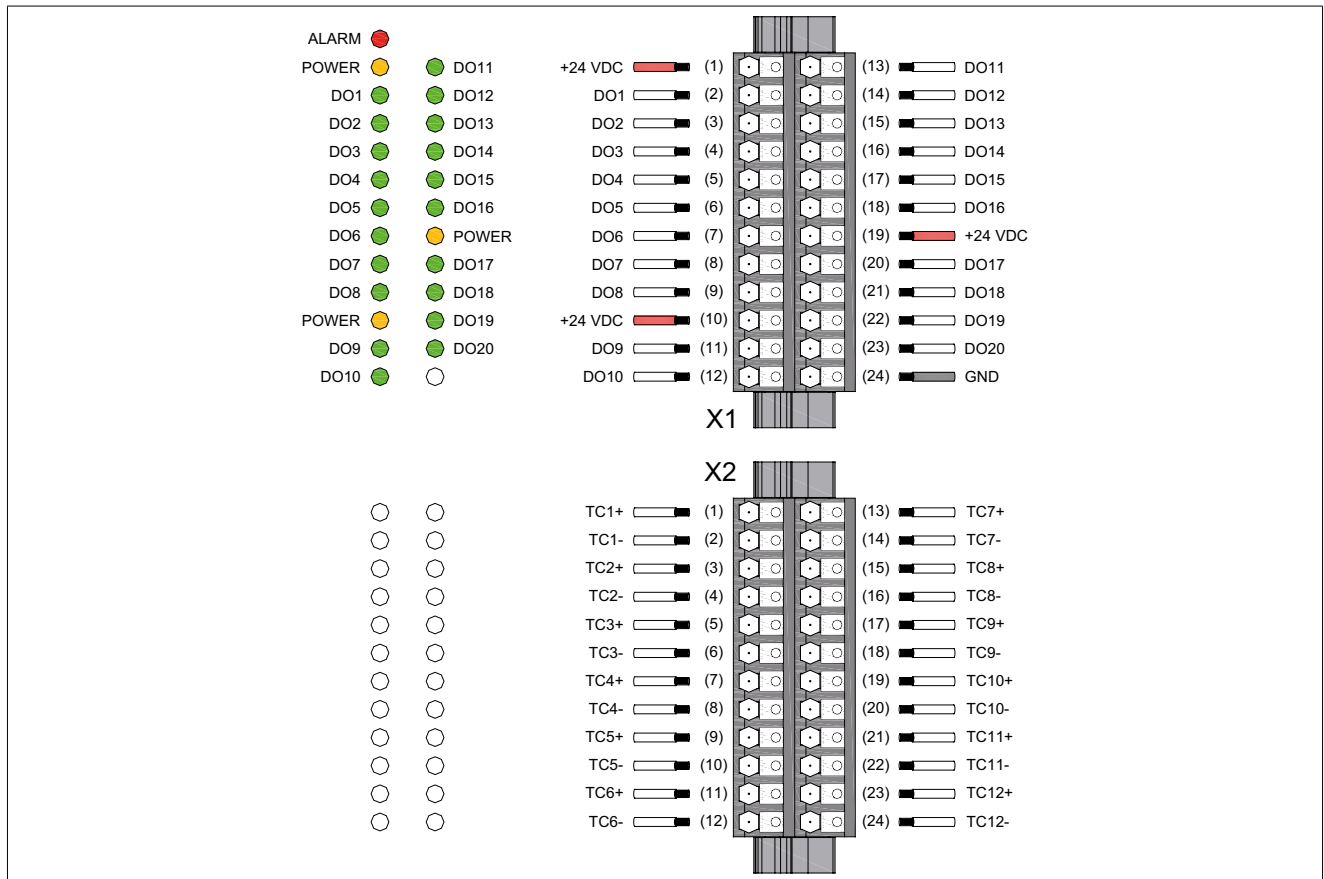

e431 connection diagrams

Digital outputs

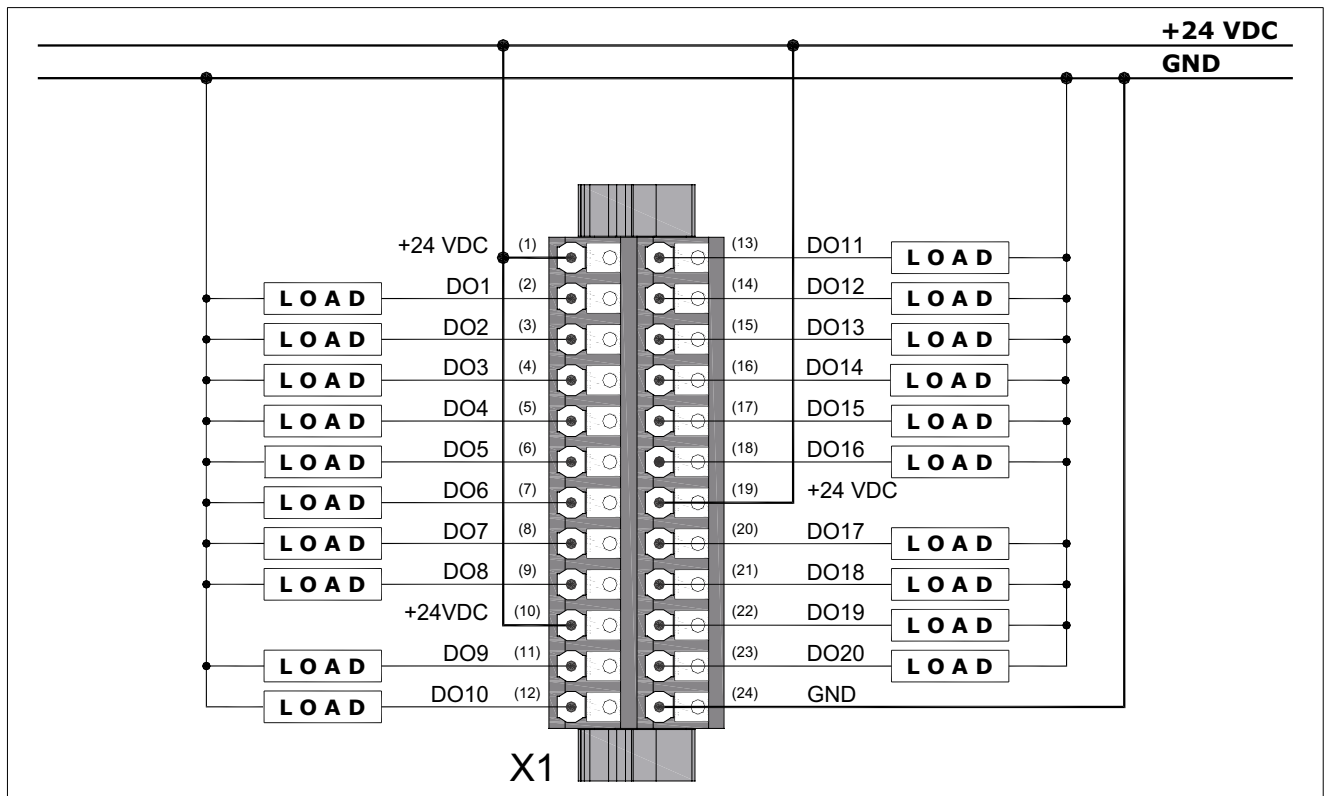

Analog input - Thermocouple

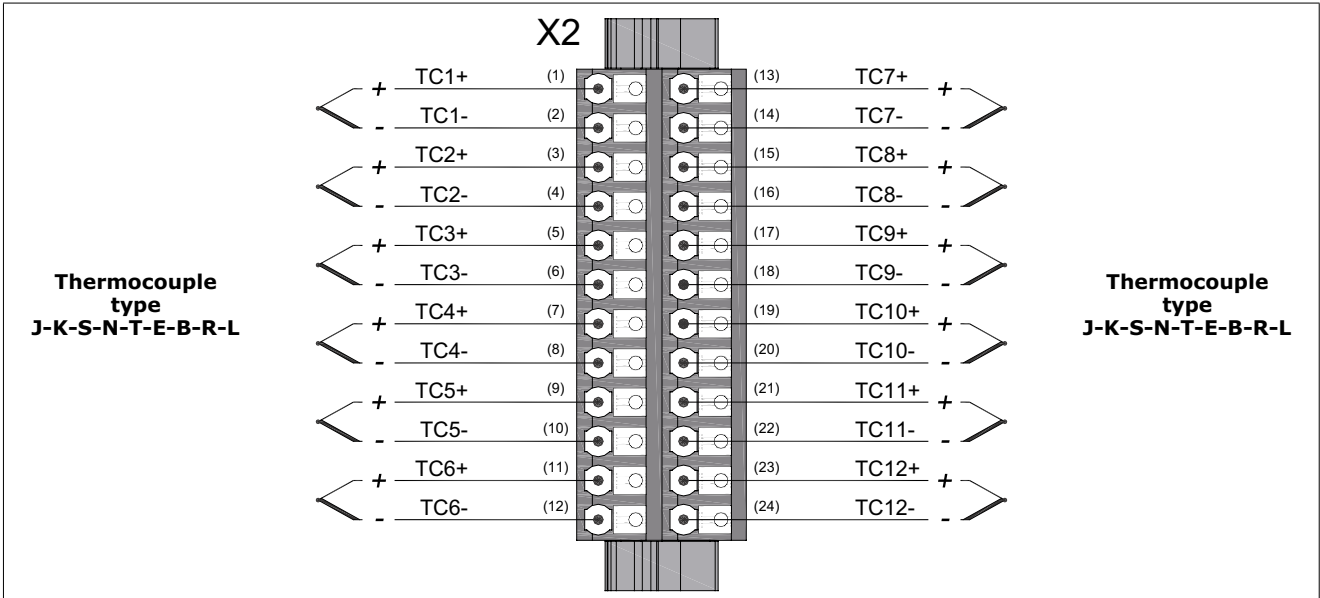

For the connection use a compensated cable.

If using a screened cable, connect the screening to the earth bar as close as possible to the probe.

The screening is connected to earth on the hot joint of the probe.

COMMISSIONING

Setup program

After you have made all of the connections, switch on power to the system and proceed to setup.

The following screen is seen when the system is booted:

```
*****
*
*          GEFTRAN SYSTEM SETUP          *
*          ver. = 2.04                    *
*          to access system configuration *
*          hold [ F1 ]                    *
*          or                             *
*          touch anywhere on the screen  *
*          for a few seconds              *
*
*****
```

If a keyboard is present, keep the F1 key pressed; if not, press the ePanel touchscreen to access the setup program.

Authentication

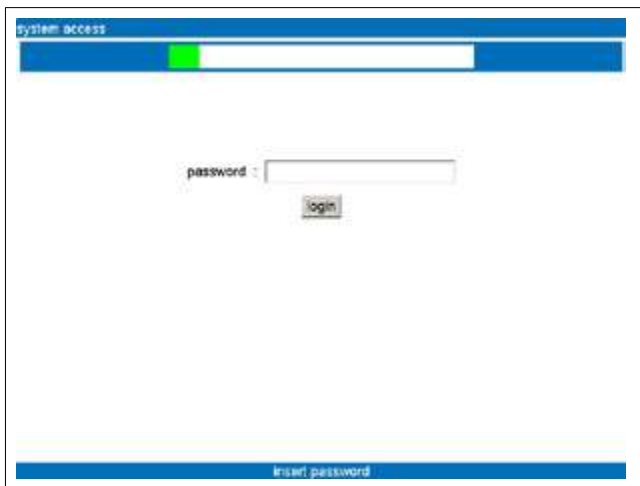

The first page requests authentication. The default password for access is *geftransetup*.

Press the *login* button to send the password. If the password is not sent within 30 seconds, the terminal reboots.

Time is shown by a colored bar at the top of the page.

After authentication, the main menu appears

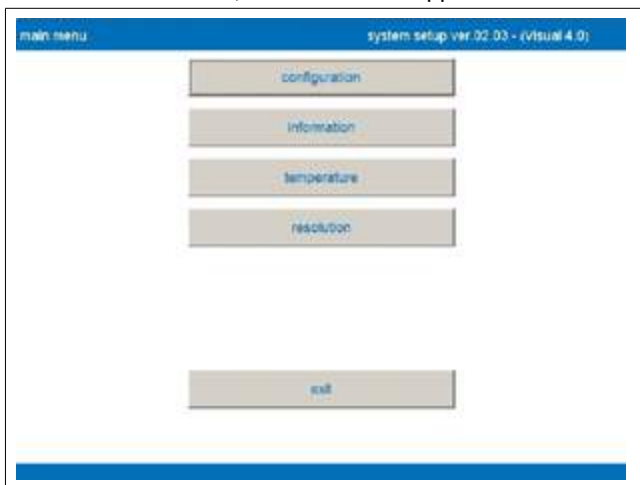

Select the item required to access the submenu. *Exit* quits the setup program and reboots the system.

Configuration

Here you set the date and time, change the password, set network parameters, and configure the touchscreen.

Press *Home* to return to the main menu.

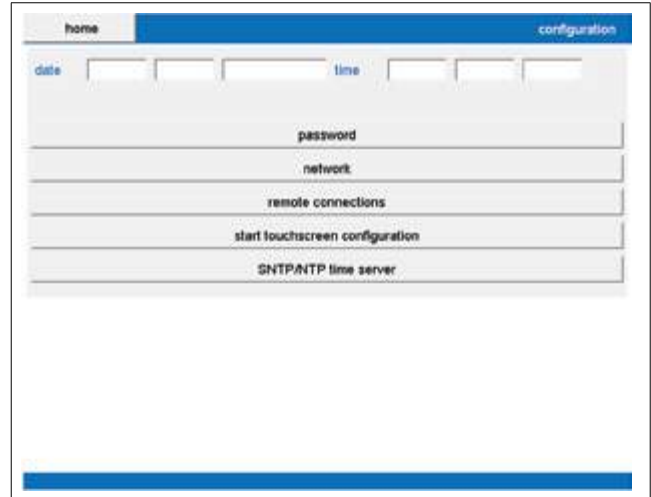

Date and Time

To change a data item, touch the item in question with your finger. A number pad appears.

Enter the new item and confirm with *OK*, or cancel the operation with *CANCEL*.

If the settings are gray they cannot be changed, because an SNTP server is on (automatic update of date and time).

Password

To change the password for access to the setup program, press the *Password*.

The following page appears:



Touch the screen on the *new password* box.

An alphanumeric pad appears. The new password must be at least 5 characters in length. You can use the characters a...z, A...Z, 0...9 for the password.

Write the new password and press the *change password*.

A pop-up window appears: write the new password again and press *OK*.

If the two new passwords are identical the password is changed; if not, an error message appears and you have to rewrite the password.

Press *Home* to return to the main menu, press <<-back to return to the previous menu.

Network

Press the *Network* button to configure the various network ports.

The following page appears:

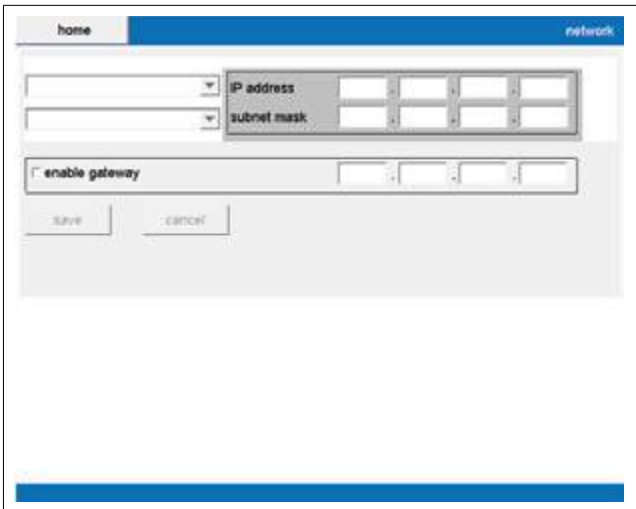

The first pull-down menu shows the available network ports (ex.: ETH #1). The second pull-down menu shows the protocols that can be used (disabled, TCP/IP, GDNNet or EtherCAT) with that port.

If required by the protocol, the panel to configure the IP address and subnet mask also appears. The default IP address is 192.168.0.1.

To change a data item, touch the item in question with your finger. A number pad appears.

Enter the new item and confirm with *OK*, or cancel the operation with *CANCEL*.

The save and cancel buttons activate if changes are made. Changes are applied only when the application program is rebooted.

Enable gateway: lets you configure a gateway (or router) by means of which the target can communicate with the other subnetworks in the network structure.

Attention: this parameter will change only at the NEXT REBOOT. In addition, this parameter may be overwritten by running deploy from the GF_Project development environment.



Attention: After saving, you cannot recover old data (no UNDO function).

Il pulsante *Home* consente di tornare al menu principale, il pulsante <<-back riporta al menu precedente.

Start touch screen configuration

To configure the touch screen, press the *Start touch screen configuration*.

The following page appears:



Calibration is done on a page with 5 targets in sequence. The targets have to be touched with a plastic tip.

After the 5th target is touched, the system automatically exits the calibration procedure and returns to the setup program.

SNTP/NTP time server

Press the "SNTP/NTP time server" button to configure a synchronization server for date and time.

The following page appears:



The settable parameters are:

- Enable time sync with SNTP/NTP server Activates communication with an SNTP/NTP server to automatically synchronize the system clock
- Server Address IP address of SNTP/NTP server to contact
- Port Communication port for the SNTP/NTP protocol. Normally 123. Contact the Server supplier or installer for the exact port used.
- Time fuse correction (secs) Time correction for applying the current time zone. The value is expressed in seconds (3600 = 1 hour) as the difference from the reference time zone (GMT 0). The value can be positive or negative.
- Enable DST (Daylight Saving) Add 1 hour to the time received to compensate for Daylight Saving Time (if applicable).

Press “Save” to save the changes and immediately update the communication parameters with the server.

A function message will appear with the following information:

- Stopped: the SNTP/NTP service is inactive
- ERROR: communication error with server
- Connecting: trying to communicate
- Running: communication with server is on and clock is synchronized in real time

If the server cannot be reached, make sure its IP address belongs to the same subnetwork as the target.

If not, configure the gateway parameter on the network page.

Attention: these parameters are overwritten by running deployment from the GF_Project development environment.

Remote connections

On this page you can activate the services of Web server and VNC server.



Information

Gives information on installed firmware versions, allows access to log files, and lets you check the installed GAB version.



- *bootrom.sys* shows the bootrom version (system bootloader).
- *gefran.os* shows the terminal BSP version.

- *seven.out* shows the active firmware version on the terminal.
- *seven.jar* shows the active Java firmware version on the terminal



Attention: the page shows only the informations found .

Press *Home* to return to the main menu.

Log Files

Press the log files button to work on *Log files*. The following page appears:



The pull-down menu at the top lets you activate a content display filter.

The options are:

- LOG: text file containing diagnostics
- ERR: text file used to save any errors.

The list of found files is shown in the left panel. The pull-down menu at the bottom lets you select the saving device to be checked when searching files.

Disk free space shows the free space on the selected saving device

Select *Save exceptions to file* to activate the saving of any system exceptions in a diagnostics file (SYSERR_dataora.log).

The change will take effect at the next reboot



Attention: This setting is always overwritten when you load a program with GF_ProjectVX.

If you select a file in the left panel, keys on the right activate to let you see file contents (*Show file*) copy contents to a USB drive inserted in the operator panel or the ePCLoLogic400 controller (*Copy to USB*) and delete the file (*Delete*).



Attention: Deletion cannot be undone: the file is deleted permanently.

Press *Home* to return to the main menu <<-back to return to the previous menu.

Check version files

Press the *Check version files* button to activate the check of the installed version and of the individual softwares/components it includes. The following page appears:

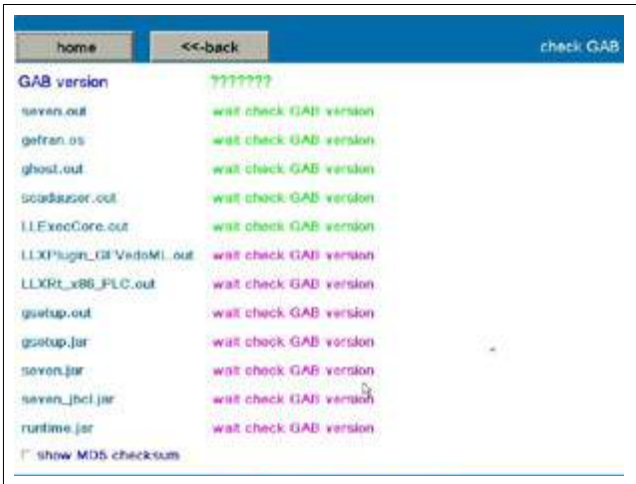

The lines change from purple to green as the checksum is checked.

If the checksum is correct, the line stays green and the file version is shown.

If the checksum is wrong, the line turns red and the message “wrong MD5 checksum found!” appears next to the version. Click the *show MD5 checksum* box to see the checksum value immediately



Press *Home* to return to the main menu. Press *<<-back* to return to the previous menu.

Temperature

Gives information on the temperatures measured in the ePCLoLogic400.

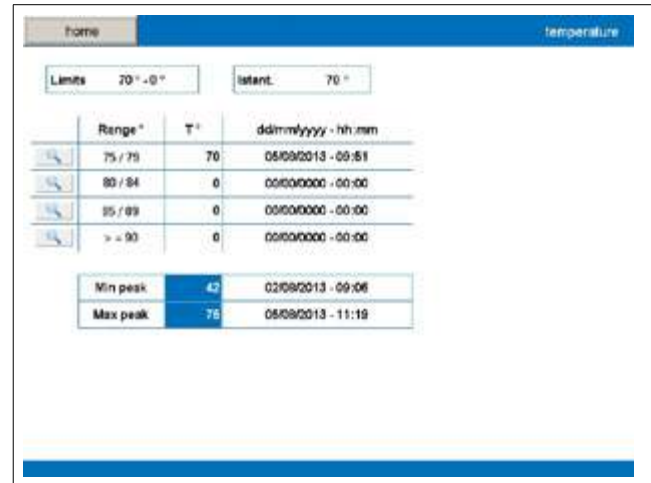

- *Limits* shows the temperature limits for normal operation
- *Istant.* shows the current temperature.

For every overtemperature interval, the table shows the last measured value and the date and time the overtemperature occurred.

Min peak and *Max peak* show the minimum and maximum temperature measured, with the date and time of measurement.

Press *Home* to return to the main menu

Press the magnifying glass icon on the table to access the historical file for that temperature interval.



You can go from one temperature interval to another by pressing the relative tab.

Press *Home* to return to the main menu. Press *<<-back* to return to the previous page

Resolution

This lets you change the resolution and orientation of the display so that they conform to the operator panel used (ePCLogic400 leaves the factory with horizontal 800 × 600 resolution).

The following page appears where the settings read are shown in green.

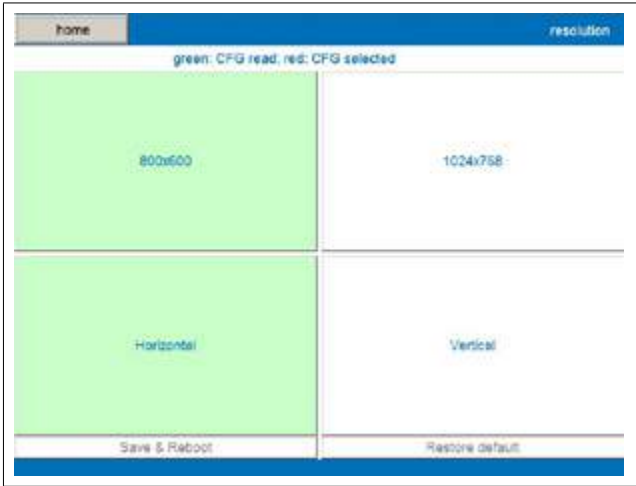

Select the resolution or orientation to be changed. The related box turns red.

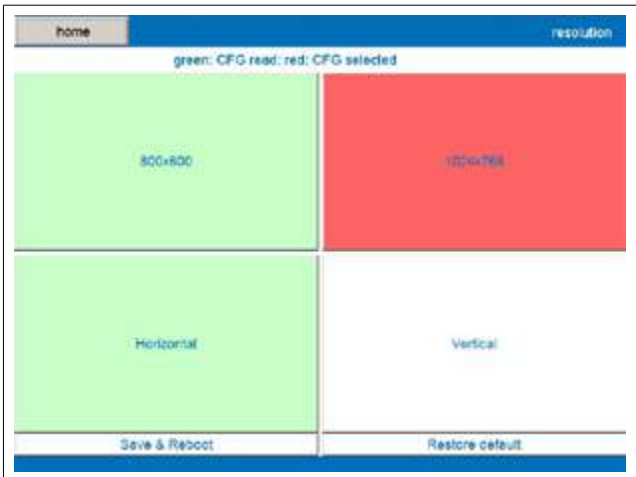

The following buttons are activated:

- *Save & Reboot*: saves the new configuration and reboots the system
- *Restore default*: restores the last setting saved





















Press *Home* to return to the main menu.

eGT-I - OPERATOR INSTRUCTIONS

Keys and signals

The eGT-I Operator Panel has 43 keys, 6 of which have signal LEDs.

The functions assigned to the 34 preprogrammed keys are shown in the following table.

Key	Function	Notes
	Manual molding	
	Manual	
	Semiautomatic	
	Automatic	
	Start cycle	
	Heating ON/OFF	
	Pump	
	Open mold	
	Close mold	
	Extrusion screw forward	
	Extrusion screw rotation	
	Extrusion screw back	
	Rotation 1 inside	
	Rotation 1 outside	
	Rotation 2 inside	
	Rotation 2 outside	
	Extractor forward	
	Extractor back	
	Plasticization and injection group forward	
	Plasticization and injection group back	
	Purge	

Key	Function	Notes
	Rotation 3 inside	
	Rotation 3 outside	
	Rotation 4 inside	
	Rotation 4 outside	
	Open protective screen	
	Close protective screen	
	Mold assembly forward	
	Mold assembly back	
	Lubrication	
	Blowing	
	Blowing	
	Blowing	
	Blowing	

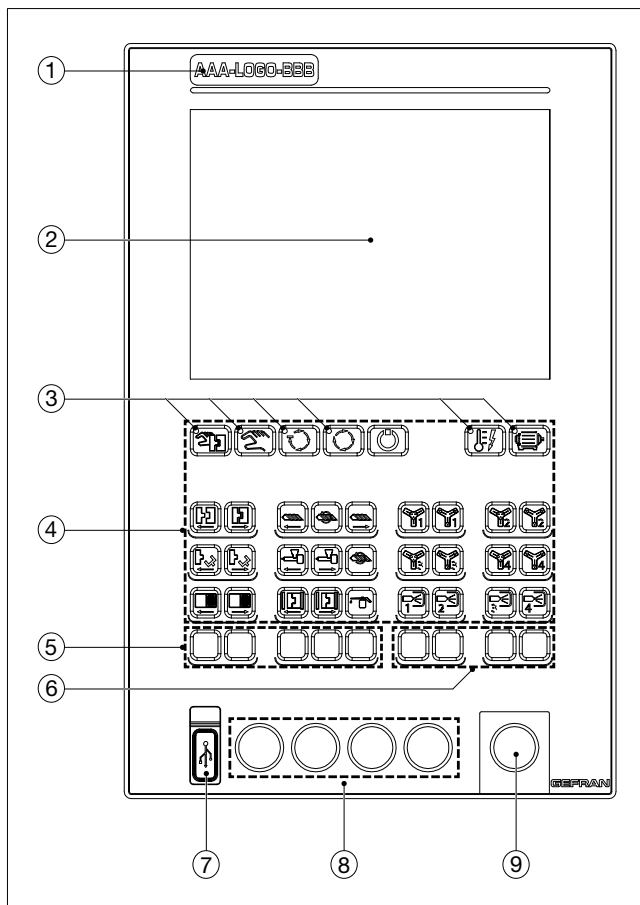

1	Customizable logo pocket
2	10.4" Display
3	Machine status LED (4 blue + 2 red)
4	Controls (34)
5	Configurable keys (5)
6	Configurable keys (4)
7	USB KEY
8	Holes for electromechanical keys (4, ø 22 mm)
9	Hole for mushroom emergency button

MAINTENANCE AND DIAGNOSTICS

Maintenance

Operator Panel

Use only a soft, slightly damp cloth to clean the screen. Do not use chemicals or abrasives. Switch off the power supply before cleaning the panel.

ePCLoLogic400 controller

The controller does not require any maintenance.

Disposal



The Operator Panel and the ePCLoLogic400 controller (with modules) must be disposed of in compliance with current regulations. Some of the components used in the devices may harm the environment if not disposed of correctly.

Local diagnostics

ePCLoLogic400 controller

In the event of any malfunctions, check the LED signals on the CPU module to determine the cause and identify the remedy.

LED		Meaning	Boot	Runtime
PW	(yellow)	POWER	On steady	On steady
RN	(green)	PLC program diagnostics	On steady	On steady: application program exists, has been loaded, and is running. Off: Error, application program not running.
E1	(red)	Local bus error	On steady	On steady: communication errors on local bus. Off: normal operation.
E2	(red)	Hardware watchdog	On steady	On: HW watchdog tripped. Off: normal operation.
E3	(red)	Software watchdog	On steady	On: SW watchdog tripped.
E4	(red)	PLC program diagnostics	On steady	On steady: PLC 1131 program not running. Off: normal running

Diagnosics program

The diagnostics program:

- provides information for diagnosing problems with CAN peripherals;
- provides information for diagnosing problems with GDNNet peripherals;
- provides information for diagnosing problems with GILOGIK II peripherals;
- provides information for diagnosing problems with ePCLoLogic400 peripherals (I/O modules of ePCLoLogic400 system);
- provides system information (firmware versions, disk memory use, RAM use).

The diagnostics program can be inserted in a work application and does not interfere with operation of the PLC.

Launch the diagnostics program as follows:

- set the ePCLoLogic400 rotary selector to D, or
- call up the Diagnostics function from your application (if present).

Calling up diagnostics pages requires closing the pages of your application and opening pages of the system.

PLC operation does not change. To return to your application pages, click the *EXIT* button on the *Index* page. The homescreen appears.



The top tool bar contains:

- the *Home*, button for returning to the starting page (*Index*);
- the *Prev*, button for returning to the previous page;
- the name of the current page;
- the version of the diagnostics program.

The bottom tool bar contains buttons for accessing pages with information on the CANopen, GDNNet, GILLOGIK II and ePCLogic400 buses, in addition to system information (System).

The tool bars are identical on all program pages.

CANopen

Click the *CANopen* button on the bottom tool bar to access diagnostics of the network and of CAN devices.

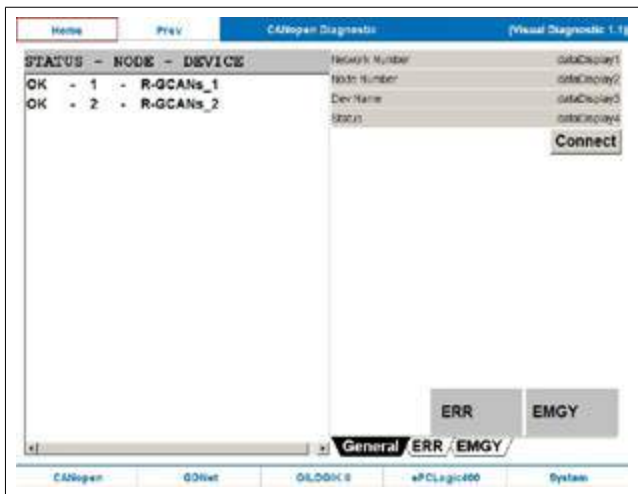

The page that opens is divided into two sections:

- CANopen network devices are listed on the left,
- details of the selected device are shown on the right.

The *Connect* button reboots the device connection procedure.

In case of error, the *ERR* label turns red.

In case of error, the *EMGY* label turns yellow.

The following information is given for each *CAN* device on the list:

- Device status (STATUS). which can be:
 - OK: device connected;
 - ERR: device not connected after an error between CAN Master and Slave;
 - EMGY: device sends Master a CAN Emergency message
- Node number (NODE).
- Device name (DEVICE). The name is the one set in GF_Net.

General information

To see general information, select the device from the list on the left and the *General* tab at the bottom right.

Available information:

- *Network Number*: number of the CAN network to which the device is connected.
- *Node Number*: node number assigned to the device.
- *Dev Name*: device name as defined in GF_Net
- *Status*: device status as defined in the CANopen standard.

Error information

To see error information, select the device from the list on the left and the *ERR* tab at the bottom right.

Available information:

- *Network Number*: number of the CAN network to which the device is connected.
- *Node Number*: node number assigned to the device.
- *Dev Name*: device name as defined in GF_Net.

If there is an error, the following information is also seen:

- *Type*: type of error.
- *Descr*: brief description of error.

Based on the type of error, there is a series of additional information:

- *Err connecting PDO Tx (S => M)*: occurs when the Master cannot assign a COBID to a PDO (here, in reception) because it is already reserved by another device in the network. In this case, the first PDO in Rx with a duplicated COBID will be highlighted. Search for the indicated COBID in GF_Net to find the PDO causing the problems.
- *Err connecting PDO Rx (M => S)*: occurs when the Master cannot assign a COBID to a PDO (here, in transmission) because it is already reserved by another device in the network. In this case, the first PDO in Tx with a duplicated COBID will be highlighted. Search for the indicated COBID in GF_Net to find the PDO causing the problems.
- *Err Check Fail*: occurs when the Master cannot end the Check phase. The Master checks that the physically connected device is really the one expected by checking the value of a series of CANopen objects on a list defined in GF_Net ("SDO Check"). In this case, the CANopen device with the error will be highlighted, showing Index and SubIndex and specifying, as appropriate:
 - a possible problem due to failed reception of the SDO,
 - possible reception of an ABORT message,
 - a possible difference between the expected value (defined in the GF_Net Value column) and the one actually present on the device

- *Err Setup Fail*: occurs when the Master cannot end the Setup phase. The Master sends the physically connected device a series of CAN objects to configure the device.

The list of objects is defined on a list in GF_Net (“SDO Set”). In this case, the CANopen device with the error will be highlighted, showing Index and SubIndex and specifying, as appropriate:

- a possible problem due to failed reception of the SDO,
- possible reception of an ABORT message.

- *Err Starting Fail*: occurs when the Master does not see the CAN device switched to OPERATE after sending the required command. This may occur because:

- at start the Master did not receive all of the required PDOs from the Slave (in this case, the first PDO NOT received will be highlighted),
- at start the Master detects that the Slave is in the wrong position (in this case, the expected value and the real value of the Slave will be shown),
- at start the Master received from the Slave at least one PDO with length (DLC) differing from the one defined in the con_net.ini file (in this case the PDO causing the error will be highlighted).

Search for the indicated COBID in GF_Net to find the PDO causing the problems.

- *Err Node Guard*: occurs when the Node Guarding protocol between Master and Slave fails. Possible causes:

- the Slave node does not send the reply to Node Guarding,
- the Slave node is not in the status expected by the Master,
- the Slave node does not toggle the bit.

- *Err SDO Input Fail*: occurs when SDO dialog between Master node and Slave fails in Read.

The list of exchanged CANopen objects is defined on the “SDO Input” table built in GF_Net.

The following will be specified:

- if the error occurred during the SDO Read phase,
- the CANopen object in which the error occurred, showing Index and SubIndex,
- as appropriate, a possible problem due to failed reception of the SDO or possible reception of an ABORT message

- *Err SDO Output Fail*: occurs when SDO dialog between Master node and Slave fails in Write.

The list of exchanged CANopen objects is defined on the “SDO Output” table built in GF_Net. The following will be specified:

- if the error occurred during the SDO Write phase,
- the CANopen object in which the error occurred, showing Index and SubIndex,
- as appropriate, a possible problem due to failed reception of the SDO or possible reception of an ABORT message

- *Err PDO Tx (S ⇒ M) control*: occurs when control by the Master of PDOs in reception fails. In this case, the first PDO NOT received will be highlighted.

Search for the indicated COBID in GF_Net to find the PDO causing the problems

- *Err Network Fail*: occurs when the Master detects a HW error in the network. In this case, a series of possible causes is shown for troubleshooting

- *Err Node not Exist*: occurs when the Master does not detect the presence of the Device in the network.

Emergency information

To see information on the Emergency message sent by the Slave device, select the device from the list on the left and the *EMGY* tab at the bottom right.

Available information:

- *Network Number*: number of the CAN network to which the device is connected.
- *Node Number*: node number assigned to the device.
- *Dev Name*: device name as defined in GF_Net
- *Emgy ErrCode*: contents of Emergency message Error Code field according to CANopen standard
- *Emgy ErrReg*: contents of Emergency message Error Register field according to CANopen standard
- *Aux Code (byte 1)*: shows first data byte of Emergency message.
- *Aux Code (byte 2)*: shows second data byte of Emergency message
- *Aux Code (byte 3)*: shows third data byte of Emergency message
- *Aux Code (byte 4)*: shows fourth data byte of Emergency message.

Click the Hex box to display the error codes and byte contents in hexadecimal format instead of decimal format.

If there is no error, the value of the error codes and byte contents is zero.



Attention: Although coded according to a general standard, the indication of local errors by the device is often specific to the device in use. Therefore, it is advisable to refer to the Slave device manual.

EtherCAT

Click the EtherCAT button on the lower navigation bar to access diagnostics of the network and of EtherCAT devices.



The component is divided into 3 Zones:

- a line describing network status,
- a list of EtherCAT devices described in the system
- a button that lets you access advanced information on the network.

The description line is divided into 2 sections.

The first part (on the left) has the following structure:

EtherCAT (ETH# 2): 8

The number in parentheses indicates the physical card (as seen by the 'ipconfig' shell command or by gsetup) on which the EtherCAT network was configured.

The number 8 outside the parentheses indicates the EtherCAT network activation status.

- 1 INIT.
- 2 PREOPERATIONAL.
- 3 SAFE OPERATIONAL
- 8 OPERATIONAL.
- +16 Error Flag in OR in above cases

The second part (on the right) with message and relative color indicates the diagnostics of the EtherCAT master:

- "OK" Green – Good operating condition;
- "Cable disconnected" Red – Communication bus probably disconnected; no slave in communication;
- "Slave(s) not connected" Red – One or more slaves not connected;
- "Not OK" Orange – Master in generic error condition
- "Slave(s) status not expected" Red – One or more slaves in unexpected status;

The main window lists the configured devices. Several columns are shown, with the following content:

- **Status: operating status:**
 - "----" Slave not previously communicated with;
 - "INIT" Slave in init condition;
 - "PREO" Slave in Pre Operational condition;
 - "BOOT" Slave in bootstrap condition;
 - "SAFE" Slave in Safe Operational condition
 - "OPER" Slave in Operational condition (running);
 - "MISS" Slave 'lost';
 - "* " Error condition (in or with preceding)
- **ID:** Unique device identifier (as inserted in HW configurator). Useful for pointing at device in PLC code.
- **device name:** device name (as inserted in HW configurator).

Note on ID

Each device has a unique number (ID) for identification (including by PLC).

This number is assigned automatically, but can be changed manually in the HW configurator

Device section

Click on one of the listed devices to access the diagnostics for that device.

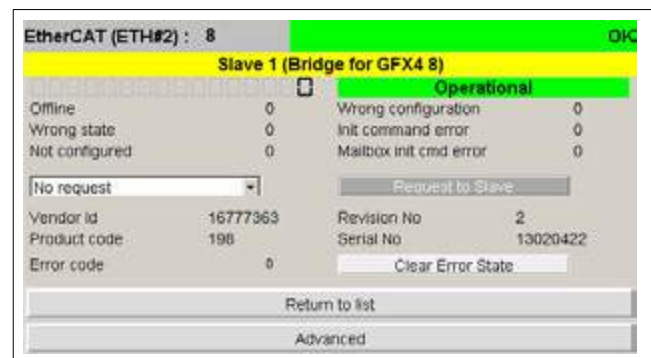

The first line is the same as on the main menu, followed by:

- **Name device:** name (shown in yellow);
- **Diagnostic:** diagnostics of slave in binary
- **The lower section explains the meaning of each bit;**
- **Status: Operating status**
 - "----" Slave not previously communicated with;
 - "Init" Slave in init condition
 - "Pre Operational" Slave in Pre Operational;
 - "Bootstrap" Slave in bootstrap condition;
 - "Safe Operational" Slave in Safe Operational condition
 - "Operational" Slave in Operational condition (running)
 - "Missing" Slave 'lost';
 - "(Err)" Error condition (in or with preceding);

- *Request Status to slave*: interface to request new status to slave: No request, Init, Pre Operational, Bootstrap, Safe Operational, Operational;
- *Slave information*: generic information on slave:
- *Vendor Id*;
- *Product Code*
- *Revision Number*
- *Serial Number*
- *Slave Error Code*: slave error code;
- *Clear Error State*: button to clear slave error state;

The lower section has two buttons:

- *Return to list*: return to slaves list;
- *Advanced*: go to diagnostics of master

Advanced section

Click on the Advanced button to access diagnostics of the master.

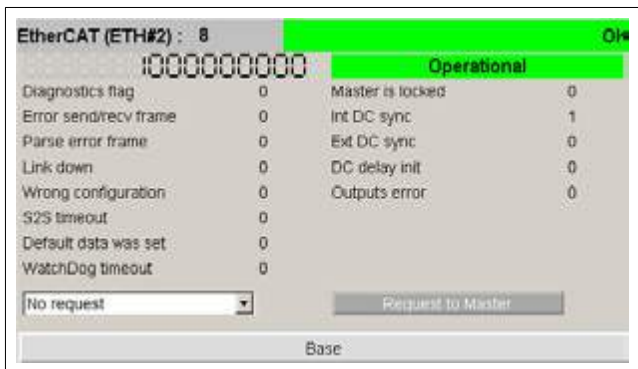

The first line is the same as on the main menu, followed by:

- *Diagnostics*: diagnostics of master in binary
- *The lower section explains the meaning of each bit*
- *Status*: Operating status:
"Init" Master in init condition ;
"Pre Operational" Master in Pre Operational condition;
"Bootstrap" Master in bootstrap condition;
"Safe Operational" Master in Safe Operational condition;
"Operational" Master in Operational condition (running);
- *Request state to master*: interface to request new status to master: No request, Init, Pre Operational, Bootstrap, Safe Operational, Operational;

The lower section has one button

- *Base*: to return to base interface: list of slaves or diagnostics of slave

GdNet

Click the GdNet button on the bottom tool bar to access diagnostics of the network and of GdNet devices.

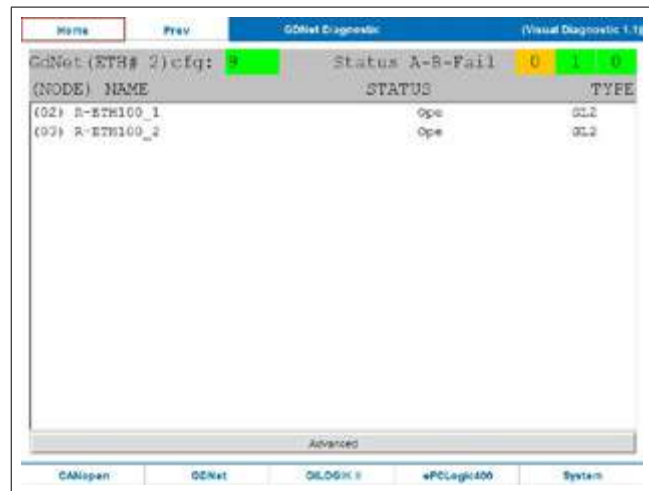

The window shows:

- a top bar describing network status,
- a list of GdNet devices in the network;
- the Advanced button to access advanced information.

Network status

The top bar shows the following information:

- *GdNet (ETH# ...)*: the number in parenthesis after *ETH#* indicates which physical card was configured for the GdNet network. You can obtain the same information with the Network section of the Setup program.
- *cfg: x*: the number x, which corresponds uniquely to its background color, indicates the GdNet activation status:
 - 1 (dark gray): GdNet activation not yet launched.
 - 2 (cyan): GdNet assigned to more than one network.
 - 3 (magenta): GdNet assigned to non-supported HW.
 - 4 (yellow): GdNet I/O cfg file not found.
 - 5 (red): elaboration of I/O cfg file ended with error.
 - 6 (blue): GdNet not configured.
 - 7 (light gray): no device found in GdNet I/O cfg file.
 - 8 (dark green): GdNet activating.
 - 9: (bright green) GdNet activation ended correctly; otherwise, unexpected error (black).
- *Status A-B-Fail*: network operation index (level one), shown by the status of 3 variables represented by 3 colored number squares. In order from left to right, the color indicates:
 - Status A: equals 1 (green) if all configured devices are correctly connected and present with all configured cards.
In practice, the functional conditions are identical to the configuration. Otherwise, equals 0 (yellow), indicating that at least one device or a single card of a device is not present. Nevertheless, this is a correct and permissible functional condition.

- Status B: equals 1 (green) if all detected devices are correctly connected, even if fewer than the configuration, and if there is no mismatch of detected cards (see GetCards). In addition, all of the valid cards found when the device was first connected must be present. Otherwise, equals 0 (red), indicating that at least one previously-connected device is not connected, or that at first connection a single card of a device is in mismatch, or that a single card found at first connection is no longer present.
- Fail: equals 0 (green) if no card of any device has an active A or P fault. Otherwise (at least one card has an active A or P fault) equals 1 (red)..

Network devices

The center window lists the configured devices. The 3 columns show the following information:

- **(NODE) NAME:** node number set with rotary selector and name entered in HW configurator.
- **STATUS:** device function status. May be as follows:
 - [empty]: Slave not configured.
 - Cfg: Configured Slave not found
 - Sw0: Slave about to go operational
 - Mis: Slave lost.
 - Prg: Slave in program.
 - Ope: Slave operative.
- **TYPE:** device type. May be as follows:
 - MC: Motion control (drive).
 - GL2: GiLogik.

Scroll the list with the touch screen and double-click to select an element from the list.

Selecting an element from the list lets you go to more detailed diagnostics (level 2 and 3 or device and card level) with display of a panel dedicated to the selected device.

Advanced section

Click the Advanced button to access 2 pages for advanced diagnostics, displaying values of a series of specific counters (useful in case of service request).

GILOGIK II

Click the GILOGIK II button on the bottom tool bar to access diagnostics of GILOGIK II devices

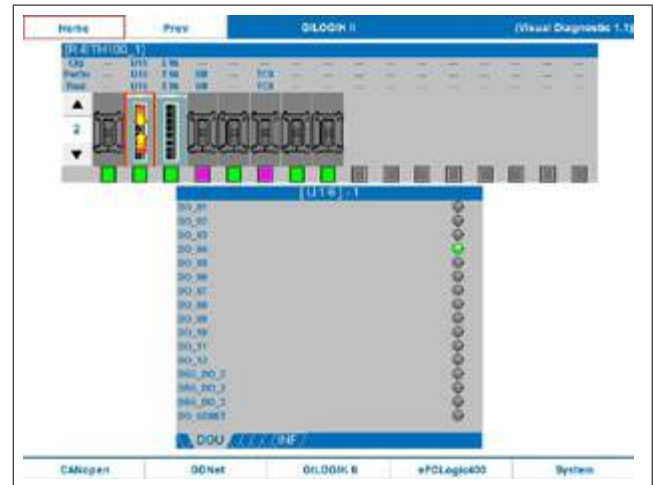

The window shows:

- identification of the network node at the top left,
- a graphic representation and description of the node cards and their status,
- two arrow keys for moving among the nodes,
- detailed status of the cards of the selected node.

Node identification

The node is identified with a generic progressive indication or with the name it was given when configured.

To select another node (if present), use the arrow keys on the left.

Connected cards

Information is shown in tabular form. Each column represents a card, for which the following information is shown:

- **Cfg:** card name at time of configuration
- **PwOn:** card name - shows which card was recognized at time of power-on.
- **Real:** card name recognized now
- **Card icon:** identifies card type. May assume the following shapes:
 1. Slot with configured card.
 2. Slot with non-configured card.
 3. Slot not managed

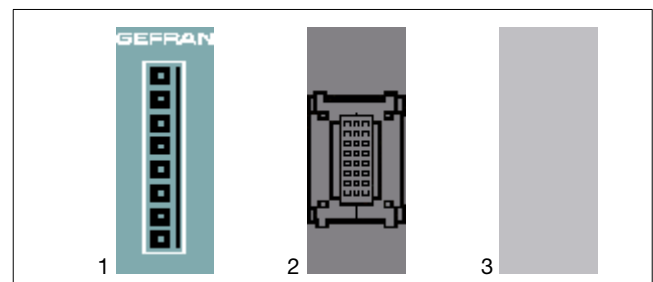

- *Flag*: shows slot status with colored code. Meanings:
 - Green: Slot with card correctly configured.
 - Yellow: card configured but not inserted in slot.
 - Blue: card added to powered-on terminal.
 - Violet: Error. At power-on, the card is in a non-configured slot or a slot configured for a different card.
 - Red: card malfunctioned during operation (red with white point at center = card terminal shorted).
 - Gray: slot not managed / invalid slot.

Detailed status of card

Click the icon of one of the listed cards: details of the status of its terminals are shown in the bottom box.

For example, in the figure the first device ([U16] - 1) has been clicked.

The names of the variables are listed on the left; their values are shown on the right.

These signals repeat any signals present on the card. The tabs under the box have the following meaning:

- *DIN*: digital inputs.
- *DOU*: digital outputs.
- *AIN*: analog inputs.
- *AOU*: analog outputs.
- *T_C*: analog temperature inputs.
- *D_A*: physically digital inputs and outputs managed as analog by the program.
- *INF*: card information.

If a card does not have even one terminal of a defined category, its tab will be displayed without label..

ePCLogic400

Click the ePCLogic400 button on the bottom tool bar to access diagnostics of ePCLogic400 modules.

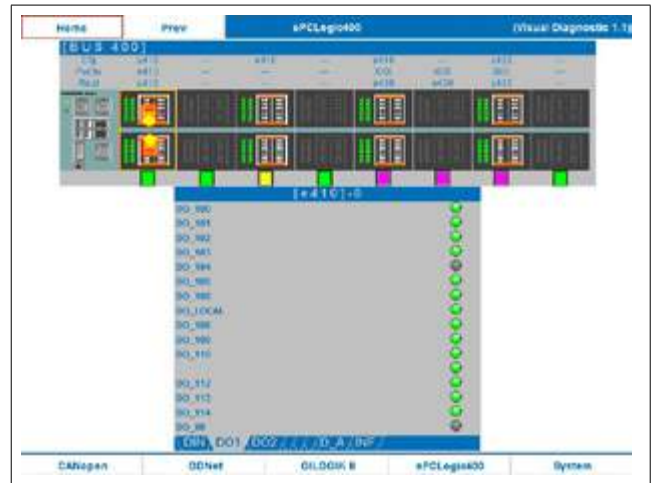

The window shows:

- network identification (BUS 400) at the top left
- a graphic representation and description of the installed modules and their status,
- detailed status of the selected module.

Installed modules

Information is shown in tabular form. Each column represents a module (e410 or e430), for which the following information is shown:

- *Cfg*: shows which module was present at time of configuration.
- *PwOn*: shows which module was recognized at time of power-on.
- *Real*: shows which module is recognized now.
- *Module icon*: identifies module type.

May assume the following shapes:

1. Slot with configured module.
2. Slot with non-configured module

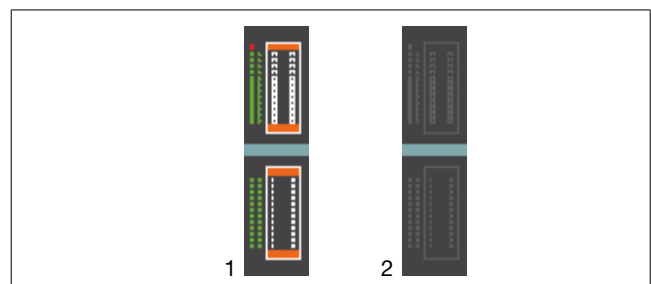

- *Flag*: shows slot status with colored code. Meanings are the same as those for GILLOGIK II.

Detailed status of module

Click the icon of one of the listed modules: details of the status of its inputs and outputs are shown in the bottom box. For example, in the figure the first module ([e410] - 0) has been clicked.

The type of information shown is analogous to that described in the paragraph “Detailed status of GiLOGIK II card.”

ICT

Click the ICT button on the lower navigation bar to access ICT diagnostics.

Status ID	Protocol & Description	node/line	Device Name
L-E [003]	M-TCP - 192.168.105.188	(010/ 0)	GFx4-IR_1
L-E [004]	M-TCP - 192.168.105.188	(011/ 0)	GFx4-IR_1
L-E [005]	M-TCP - 192.168.105.188	(012/ 0)	GFx4-IR_1
L-E [006]	M-TCP - 192.168.105.188	(013/ 0)	GFx4-IR_1
L-E [020]	M-TCP - 192.168.105.188	(014/ 0)	GF_1
L-E [008]	M-TCP - 192.168.105.189	(255/ 1)	TF32_65_1
OK [030]	M-TCP - 192.168.105.187	(022/ 2)	GFXTERMO4_1
OK [031]	M-TCP - 192.168.105.187	(023/ 2)	GFXTERMO4_1
OK [032]	M-TCP - 192.168.105.187	(024/ 2)	GFXTERMO4_1
OK [033]	M-TCP - 192.168.105.187	(025/ 2)	GFXTERMO4_1
---	M-RTU - RS-232 [COM0], 19200, None, 2	(001/ 3)	800_1
---	M-RTU - RS-232 [COM0], 19200, None, 2	(003/ 3)	800_1
---	M-RTU - RS-485 [COM2], 38400, Odd, 1	(055/ 4)	1000_1
---	M-RTU - RS-485 [COM2], 38400, Odd, 1	(066/ 4)	ADV200_1
---	M-RTU - RS-485 [COM2], 38400, Odd, 1	(040/ 4)	GFW_1
---	M-RTU - RS-485 [COM2], 38400, Odd, 1	(041/ 4)	GFW_1
---	M-RTU - RS-485 [COM2], 38400, Odd, 1	(042/ 4)	GFW_1

ICT (Industrial Central Terminal) means management of data exchange by the Gefran target to and from remote devices, which may be instruments and/or PLCs of other manufacturers, via dedicated protocols.

To date, the managed and diagnosed protocols are:

- Modbus TCP
- Modbus RTU

ICT Diagnostics Interface

The main interface of the Gefran ICT Diagnostics tool is:

Status ID	Protocol & Description	node/line	Device Name
L-E [003]	M-TCP - 192.168.105.188	(010/ 0)	GFx4-IR_1
L-E [004]	M-TCP - 192.168.105.188	(011/ 0)	GFx4-IR_1
L-E [005]	M-TCP - 192.168.105.188	(012/ 0)	GFx4-IR_1
L-E [006]	M-TCP - 192.168.105.188	(013/ 0)	GFx4-IR_1
L-E [020]	M-TCP - 192.168.105.188	(014/ 0)	GF_1
L-E [008]	M-TCP - 192.168.105.189	(255/ 1)	TF32_65_1
OK [030]	M-TCP - 192.168.105.187	(022/ 2)	GFXTERMO4_1
OK [031]	M-TCP - 192.168.105.187	(023/ 2)	GFXTERMO4_1
OK [032]	M-TCP - 192.168.105.187	(024/ 2)	GFXTERMO4_1
OK [033]	M-TCP - 192.168.105.187	(025/ 2)	GFXTERMO4_1
---	M-RTU - RS-232 [COM0], 19200, None, 2	(001/ 3)	800_1
---	M-RTU - RS-232 [COM0], 19200, None, 2	(003/ 3)	800_1
---	M-RTU - RS-485 [COM2], 38400, Odd, 1	(055/ 4)	1000_1
---	M-RTU - RS-485 [COM2], 38400, Odd, 1	(066/ 4)	ADV200_1
---	M-RTU - RS-485 [COM2], 38400, Odd, 1	(040/ 4)	GFW_1
---	M-RTU - RS-485 [COM2], 38400, Odd, 1	(041/ 4)	GFW_1
---	M-RTU - RS-485 [COM2], 38400, Odd, 1	(042/ 4)	GFW_1

The component is divided into 2 Zones:

- a list of ICT devices described in the system.
- a button that lets you access advanced information on the network.

The main window lists the configured devices.

Several columns are shown, with the following content:

- ◇ Status: operating status:
- ◇ "----" Slave not previously communicated with;
- ◇ "ERR" Slave with which a communication error has occurred;
- ◇ "OK" Slave with which all (at least one) communication(s) were/was successful
- ◇ "L-E" Line Error. Used only for Slaves in TCP positioned on nodes not connected to the network (for example, disconnected network cable).

- ID: Unique device identifier (as inserted in HW configurator). Useful for pointing at device in PLC code.
- Protocol & Description: string describing the device. Describes type of protocol:
- "M-TCP" Modbus in TCP;
- "M-RTU" Modbus in RTU;

and additional information:

- For TCP IP address
- For RTU type of serial, COM used, baudrate, parity;
- node/line: identifies line and node.
- device name: device name (as inserted in HW configurator)

Information is shown in tabular form.

Click the ICT button to access ICT diagnostics.

Note on ID and node/line

Each device is inserted on a communication line and each line has an identification number within such line.

Obviously, devices positioned on different lines can have the same node numbers.

To positively identify each device (including by PLC), the ID lets you point uniquely at each slave as it was configured by GF_Net (manually or automatically).

A line is defined as a communication channel shared by multiple devices.

For Modbus RTU, each port (COM) is a line.

For Modbus TCP, each IP address is a line.

If there are errors on multiple devices and these are positioned on the same line, the errors may be caused by the line status (for example, detached cable).

Move to the list with the cursor keys and press "enter" to scroll the list with the "up" and "down" keys.

Press "enter" again to select an item on the list, or press "esc" to return to navigation on the page.

You can scroll the list by using the touch screen and then select an item on the list with a double click.

Selecting an item on the list lets you go to diagnostics for the requested device.

Type:	Modbus Ethernet_Tcpip	Node:	22
Descr:	192.168.105.187	Id:	30
GFXTERMO4_1 act ● sts ●			
cnt	time	buff	
OK	4	23921	22 <input type="button" value="Reset"/>
Fail	0	0	0 <input type="button" value="Reset"/>
Line [2]			
cnt	time	dev	buff
OK	16	23913	33 97 <input type="button" value="Reset"/>
Fail	0	0	0 <input type="button" value="Reset"/>
0 << -1 << 24 <input type="button" value="Go to Last Error Buffer"/>			
<input type="button" value="Return to list"/>			
<input type="button" value="Advanced"/>			

The panel's top section shows the same information as on the list:

- Type Type of communication.
- Descr Description.
- Node Modbus node.
- Id Unique identifier.
- Device name.

- Two status LEDs:
Act status of last communication made
Sts presence of at least one communication error

The center zone is divided into two parts. The top section is for the device being analyzed, while the bottom zone is for the line on which the device is positioned.

Device section

	cnt	time	buff	
OK	1485	21496	22	Reset
Fail	0	25109	14	205

The section is divided into two lines:

- successful communications (OK).
- failed communications (Fail)

Each line shows 3 values

- cnt Counter showing number of communications made.
- time tenths of a second since last communication.
- buff number of buffer of last communication.

In case of unbroken communications, the count increases and the time stays low.

In case of stopped communication, the counter stops and the time increases.

In case of communication error, the **sts** LED goes from green to yellow and stays yellow until the user resets the error with the Reset button.

The **act** LED shows the status of the last communication made.

The number under the reset button shows the error code of the last failed communication..

Line section

Line [2]	cnt	time	dev	buff	
OK	5938	21696	33	09	Reset
Fail	1	25314	30	14	205

The line section is divided the same way as the device line, but its counters count all of the communications of all the devices on the same line (shown next to the word Line).

There is also an additional field:

- dev Unique identifier of the device (on the line) to which the count refers (OK and/or Fail).

Here too there is a Reset button to reset the error latch on the line.

Buffer section

0 <=	-1	<= 24	Go to Last Error Buffer
------	----	-------	-------------------------

The bottom zone has a line for the device buffers.

The buffers group the variables to be exchanged with the device.

The left zone shows the buffers for the device and a field for setting the number of the buffer to be analyzed.

Setting a valid value lets you display the buffer's composition.

On the other hand, if you press the **“Go to Last Error Buffer”** button, you go directly to the last buffer that had an error (if and only if there is an error present).

In this case, the buffer also shows which variable caused the error and its possible causes.

The top zone of the buffer shows:

- Device name – Number of Buffer (number of line).
- BufferType.
- RemoteDataType.
- Priority.
- Enable.

The bottom zone shows a list of the variables present in that buffer.

The following are shown for each variable:

- Modbus Address.
- Dimension.
- DataType.
- Variable name.
- Cause of error
- Error code

QFXTERMO4_1 - Buffer n° 14 (Line 2)				
BufferType	RemoteDataType	Priority		
D (Write Register / Read Holding)	DATA_WORD	1		
Enable				
Address	N°	DataType	Device Name	
142	1	WORD	GFKT4_1_IsL_1	
143	1	WORD	GFKT4_1_HiL_1	D -> I_S code: 205
0 <=	14	<= 24	Return	
Return to list				
Advanced				

Push the **“Return”** button to return to device diagnostics.

Advanced section

This button lets you access a lower level diagnostics section.

This section is not yet in use.

Error codes

Alarm codes managed by Modbus protocol:		
0	no error	
200	Serial ID opening error	SERIAL_OPEN_ERROR_ERROR_MSG_MODBUS_PROTOCOL
201	ICT buffer describer error	WRONG_ICT_BUFFER_DESCRIPTOR_ERROR_MSG_MODBUS_PROTOCOL
202	error in length of buffer to be built	WRONG_DATA_LENGTH_ERROR_MSG_MODBUS_PROTOCOL
203	error in type of variable to be managed	WRONG_VAR_TYPE_ERROR_MSG_MODBUS_PROTOCOL
204	no reply message from device	NO_MESSAGE_RECEIVED_FROM_DEVICE_ERROR_MSG_MODBUS_PROTOCOL
205	FAULT message received from device	RECEIVED_FAULT_REPLY_ERROR_MSG_MODBUS_PROTOCOL
206	no dialog with MODBUS device	NO_DATA_MESSAGE_RECEIVED_FROM_DEVICE_ERROR_MSG_MODBUS_PROTOCOL
207	error in CRC of packet received	WRONG_CRC_VALUE_ERROR_MSG_MODBUS_PROTOCOL
208	error in CLIENT-ADDRESS field of packet received	WRONG_CLIENT_ADDRESS_VALUE_ERROR_MSG_MODBUS_PROTOCOL
209	error in COMMAND field of packet received	WRONG_COMMAND_VALUE_ERROR_MSG_MODBUS_PROTOCOL
210	error in START-ADDRESS field of packet received	WRONG_START_ADDR_VALUE_ERROR_MSG_MODBUS_PROTOCOL
211	error in R-COUNT field of packet received	WRONG_R_COUNT_VALUE_ERROR_MSG_MODBUS_PROTOCOL
212	error in N-DATA field of packet received	WRONG_N_DATA_VALUE_ERROR_MSG_MODBUS_PROTOCOL
213	invalid CLIENT-ADDRESS requested	CLIENT_ADDRESS_VALUE_NOT_VALID_ERROR_MSG_MODBUS_PROTOCOL
214	invalid TRANSACTION_ID received	TRANSACTION_ID_ERROR_MSG_MODBUS_TCP_PROTOCOL
215	invalid PROTOCOL_ID received	PROTOCOL_ID_ERROR_MSG_MODBUS_TCP_PROTOCOL
216	invalid DATA_LENGTH received	DATA_LENGTH_ERROR_MSG_MODBUS_TCP_PROTOCOL
217	socket opening error	SOCKET_OPEN_ERROR_MSG_MODBUS_TCP_PROTOCOL
218	server address or name assignment error	UNKNOWN_SERVER_NAME_ERROR_MSG_MODBUS_TCP_PROTOCOL
219	server connection error	CONNECT_SERVER_ERROR_MSG_MODBUS_TCP_PROTOCOL
220	frame received has incorrect length	FRAME_LENGTH_ERROR_MSG_MODBUS_TCP_PROTOCOL
221	socket transmission error	SOCKET_SEND_ERROR_MSG_MODBUS_TCP_PROTOCOL
222	socket reception error	SOCKET_RECV_ERROR_MSG_MODBUS_TCP_PROTOCOL

System

Click the *System* button on the bottom tool bar to obtain system information



The following information is shown:

- *Info versions*: number of version of Gefran.os, Seven.jar and Seven.out. firmware.
- *DISK*: Flash or SD Card memory
- *MEM*: RAM memory.

For DISK and MEM memories, the maximum amount used (MAX), the amount currently used (USED), and maximum memory size (TOP) are shown.

A semicircular dial shows the currently used memory (blue arc), available memory (green arc), and memory available in an emergency but not recommended for normal use because there would be limited residual expansion capacity (red arc).

The memory indicated with the red arc corresponds to about 10% of total memory (TOP).

GEFRAN

GEFRAN spa
via Sebina, 74
25050 Provaglio d'Iseo (BS) Italy
Tel. +39 0309888.1
Fax +39 0309839063
info@gefran.com
<http://www.gefran.com>